User's Manual

Model CX2000/CX2010/CX2020/CX2210/CX2200/CX2410/
CX2420/CX2610/CX2620

DAQSTATION CX2000

vigilantplant.[®]

Thank you for purchasing the CX2000. This manual describes the functions (excluding the communications functions), installation and wiring procedures, operating procedures, and handling precautions of the CX2000. To ensure correct use, please read this manual thoroughly before beginning operation. The following six manuals are also provided in addition to this manual. Read them along with this manual.

Electronic Manuals Provided on the Accompanying CD-ROM

Manual Title	Manual No.	Description
DAQSTATION CX1000/ CX2000 Communications Interface User's Manual	IM 04L31A01-17E	Describes the communications functions of the CX1000/CX2000 using the Ethernet/serial interface.
DAQSTANDARD for CX User's Manual	IM 04L31A01-61E	Describes the functions and operating procedure of the software "DAQSTANDARD for CX" that comes with the package.

Paper Manuals

Manual Title	Manual No.	Description
CX2000 Opration Guide	IM 04L31A01-02E	A guide providing simple explanations of control-related operations for the CX2000 (includes a chart of setting values).
CX2000 Installation and Connection Guide	IM 04L31A01-71E	Describes concisely the installation procedures and wiring procedures of the CX2000.
Precautions on the Use of the CX1000/CX2000	IM 04L31A01-72E	Cautions regarding the use of the CX2000. The same information is written on pages ii and iii of this user's manual.
CX1000/CX2000 Control of Pollution Caused by the Product	IM 04L31A01-91C	Gives a description of pollution control.

Notes

- This manual describes the CX2000, style number "S3."
- The contents of this manual are subject to change without prior notice as a result of continuing improvements to the instrument's performance and functions.
- Every effort has been made in the preparation of this manual to ensure the accuracy of its contents. However, should you have any questions or find any errors, please contact your nearest YOKOGAWA dealer.
- Copying or reproducing all or any part of the contents of this manual without the permission of Yokogawa Electric Corporation is strictly prohibited.
- The TCP/IP software of this product and the document concerning the TCP/IP software have been developed/created by YOKOGAWA based on the BSD Networking Software, Release 1 that has been licensed from the Regents of the University of California.

Trademarks

- vigilantplant, DAQSTATION, and Daqstation are registered trademarks of Yokogawa Electric Corporation.
- Microsoft and Windows are registered trademarks or trademarks of Microsoft Corporation in the United States and/or other countries.
- Adobe and Acrobat are registered trademarks or trademarks of Adobe Systems Incorporated.
- Company and product names that appear in this manual are registered trademarks or trademarks of their respective holders.
- The company and product names used in this manual are not accompanied by registered trademark or trademark symbols (® and ™).

Revisions

1st Edition	December 2001	5th Edition	July 2003
2nd Edition	March 2002	6th Edition	November 2003
3rd Edition	April 2002	7th Edition	May 2007
4th Edition	June 2003		

Safety Precautions

About This Manual

- This manual should be read by the end user.
- Read this manual thoroughly and have a clear understanding of the product before operation.
- This manual explains the functions of the product. YOKOGAWA does not guarantee that the product will suit a particular purpose of the user.
- Under absolutely no circumstances may the contents of this manual be transcribed or copied, in part or in whole, without permission.
- The contents of this manual are subject to change without prior notice.
- Every effort has been made in the preparation of this manual to ensure the accuracy of its contents. However, should you have any questions or find any errors or omissions, please contact your nearest YOKOGAWA dealer.

Precautions Related to the Protection, Safety, and Alteration of the Product

- The following safety symbols are used on the product and in this manual.



“Handle with care.” (To avoid injury, death of personnel or damage to the instrument, the operator must refer to the explanation in the manual.)



Functional ground terminal. (Do not use this terminal as a protective ground terminal.)



Protective grounding terminal



Alternating current



Direct current

- For the protection and safe use of the product and the system controlled by it, be sure to follow the instructions and precautions on safety that are stated in this manual whenever you handle the product. Take special note that if you handle the product in a manner that violate these instructions, the protection functionality of the product may be damaged or impaired. In such cases, YOKOGAWA does not guarantee the quality, performance, function, and safety of the product.
- When installing protection and/or safety circuits such as lightning protection devices and equipment for the product and control system or designing or installing separate protection and/or safety circuits for fool-proof design and fail-safe design of the processes and lines that use the product and the control system, the user should implement these using additional devices and equipment.
- If you are replacing parts or consumable items of the product, make sure to use parts specified by YOKOGAWA.
- This product is not designed or manufactured to be used in critical applications that directly affect or threaten human lives. Such applications include nuclear power equipment, devices using radioactivity, railway facilities, aviation equipment, air navigation facilities, aviation facilities, and medical equipment. If so used, it is the user's responsibility to include in the system additional equipment and devices that ensure personnel safety.
- Do not modify this product.
- The CX is designed for indoor use.

WARNING**Power Supply**

Ensure that the source voltage matches the voltage of the power supply before turning ON the power.

Protective Grounding

Make sure to connect the protective grounding to prevent electric shock before turning ON the power.

Necessity of Protective Grounding

Never cut off the internal or external protective earth wire or disconnect the wiring of the protective earth terminal. Doing so invalidates the protective functions of the instrument and poses a potential shock hazard.

Defect of Protective Grounding

Do not operate the instrument if the protective earth or fuse might be defective. Make sure to check them before operation.

Do Not Operate in an Explosive Atmosphere

Do not operate the instrument in the presence of flammable liquids or vapors. Operation in such environments constitutes a safety hazard.

Do Not Remove Covers

The cover should be removed by YOKOGAWA's qualified personnel only. Opening the cover is dangerous, because some areas inside the instrument have high voltages.

External Connection

Connect the protective grounding before connecting to the item under measurement or to an external control unit.

Damage to the Protective Structure

Operating the CX2000 in a manner not described in this manual may damage its protective structure.

Exemption from Responsibility

- YOKOGAWA makes no warranties regarding the product except those stated in the WARRANTY that is provided separately.
- YOKOGAWA assumes no liability to any party for any loss or damage, direct or indirect, caused by the user or any unpredictable defect of the product.

Handling Precautions of the Software

- YOKOGAWA makes no warranties regarding the software accompanying this product except those stated in the WARRANTY that is provided separately.
- Use the software on a single PC.
- You must purchase another copy of the software, if you are to use the software on another PC.
- Copying the software for any purposes other than backup is strictly prohibited.
- Please store the original media containing the software in a safe place.
- Reverse engineering, such as decompiling of the software, is strictly prohibited.
- No portion of the software supplied by YOKOGAWA may be transferred, exchanged, sublet, or leased for use by any third party without prior permission by YOKOGAWA.

Checking the Contents of the Package

Unpack the box and check the contents before operating the instrument. If some of the contents are not correct or missing or if there is physical damage, contact the dealer from which you purchased them.

CX2000

When you open the operation cover on the front panel, a name plate is located on the back side of the cover. Check that the model name and suffix code given on the name plate on the rear panel match those on the order.

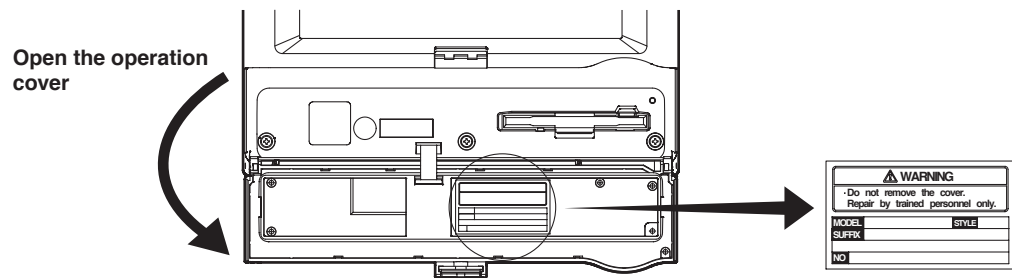

MODEL and SUFFIX

Model	Suffix Code	Optional Code	Description
CX2000			Number of internal control loops: 0, number of inputs for measurement: 0 ch
CX2010			Number of internal control loops: 0, number of inputs for measurement: 10 ch
CX2020			Number of internal control loops: 0, number of inputs for measurement: 20 ch
CX2200			Number of internal control loops: 2, number of inputs for measurement: 0 ch
CX2210			Number of internal control loops: 2, number of inputs for measurement: 10 ch
CX2220			Number of internal control loops: 2, number of inputs for measurement: 20 ch
CX2410			Number of internal control loops: 4, number of inputs for measurement: 10 ch
CX2420			Number of internal control loops: 4, number of inputs for measurement: 20 ch
CX2610			Number of internal control loops: 6, number of inputs for measurement: 10 ch
CX2620			Number of internal control loops: 6, number of inputs for measurement: 20 ch
External storage medium	-1		Floppy disk
	-2		100MB Zip disk
	-3		ATA flash memory card (Compact flash and adapter)
	-5		250MB Zip disk
Communication interface	-0		Ethernet
	-1		Ethernet + RS-232 serial interface port
	-2		Ethernet + RS-422A/485 serial interface port
Displayed language			Japanese
	-1		English
Options	-2	/A6	6 measurement alarm outputs ^{*1}
		/A6R	6 measurement alarm output, 8 remote inputs ^{*1}
		/A4F	4 measurement alarm outputs, 1 FAIL output, 1 memory end output ^{*1}
		/A4FR	4 measurement alarm outputs, 1 FAIL output, 1 memory end output, 8 remote inputs ^{*1}
		/CST1	Control extension DIO (12 DIs, 12 DOs) ^{*1*2}
		/D5	VGA output
		/M1	Computation function
		/N2	Three-wire isolated RTD (input for measurement)
		/P1	24-VDC/AC power supply driven
		/TPS4	24-VDC transmitter output (4 loops) ^{*1}
		/PG1	Program control (number of program patterns: 4) ^{*3}
		/PG2	Program control (number of program patterns: 30) ^{*3}
/BT1	Batch header		

^{*1} Only one can be specified at once.

^{*2} Cannot be specified when the number of internal control loops is 0.

^{*3} Applies only to the internal control loops, either one can be specified.

NO. (Instrument Number)

When contacting the dealer from which you purchased the instrument, please give them the instrument number.

Standard Accessories

The standard accessories below are supplied with the instrument. Check that all contents are present and that they are undamaged.

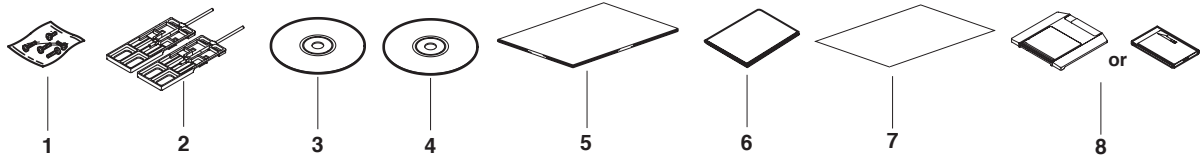

No.	Name	Part Number/Model	Q'ty	Note
1	Terminal screws		5	M4
2	Mounting bracket	B9900BX	2	For panel mounting (Optional codes other than "/H5" and "/H5M")
3	DAQSTANDARD for CX	CXA100-01	1	Software for setting the CX and displaying data CD-ROM used to install "DAQSTANDARD for CX"
4	CX1000/CX2000 electronic manual	B8700MA	1	CD-ROM containing the PDF files of this manual, the DAQSTATION CX1000/CX2000 Communication Interface User's Manual, DAQSTANDARD for CX User's Manual, and other files.
5	CX2000 Operation Guide	IM 04L31A01-02E	1	A guide providing simple explanations of control-related operations for the CX2000 (includes a chart of setting values).
6	CX2000 Installation and Connection Guide	IM 04L31A01-71E	1	Abridged paper manual
7	Precautions on the Use of the CX2000 CX1000/CX2000 Control of Pollution Caused by the Product	IM 04L31A01-72E IM 04L31A01-91C	1 1	Paper stating the precautions. Gives a description of pollution control.
8	External storage medium	A1053MP A1056MP B9968NL	1 1 1	100 MB Zip disk (provided only when the external storage medium suffix code is "-2") 250 MB Zip disk (provided only when the external storage medium suffix code is "-5") ATA flash memory card (32 MB CF card + adapter, capacity and model of CF card may vary), provided only when the external storage medium suffix code is "-3"

Optional Accessories (Sold Separately)

The following optional accessories are available for purchase separately. When you receive the order, check that all contents are present and that they are undamaged. For information and ordering, contact your nearest YOKOGAWA dealer.

Part Name	Part Number/Model	Q'ty	Note
3.5" floppy disk	7059 00	10	2HD
Zip disk	A1053MP A1056MP	1 1	100 MB 250 MB
ATA flash memory card (CF card + adapter)	B9968NL	1	32 MB (32 MB CF card + adapter, capacity and model of CF card may vary)
Shunt resistance (for the screw terminal)	4159 20 4159 21 4159 22	1 1 1	250 Ω±0.1% 100 Ω±0.1% 10 Ω±0.1%
Mounting bracket	B9900BX	2	

Spare Parts

Part Name	Part Number/Model	Note
Control output module	CXA900-01	A spare control output terminal block
Control DIO expansion module	CXA900-11	A spare control DIO expansion terminal block

How to Use This Manual

Structure of the Manual

This user's manual consists of the following sections. For details on the communications functions and the software "DAQSTANDARD for CX" provided with the package, see the respective manuals (IM 04L31A01-17E and IM 04L31A01-61E).

Chapter	Title and Description
1	Explanation of Functions Describes in detail the functions of the instrument. The chapters that explain the operation of the CX2000 only describe the operating procedures. For more detailed information about the functions, see this chapter.
2	Installation and Wiring Describes the installation and wiring procedures of the CX2000.
3	Names of Parts, Display Modes, and Common Operations Describes the names of the parts of the CX2000, the basic key operations, the basic operations carried out initially, and how to use the external storage medium drive.
4	Control Function Related Setup Operations Describes setup operations related to the control function that are carried out before starting control operations.
5	Program Control Related Setup Operations (Only on Models with the Program Control Option) Describes the setup operations related to program control that are carried out before starting control operations on models with the program control option.
6	Operations during Control Operation Describes how to switch operation mode during control operation, how to change the setpoints of setting mode, how to tune the control parameters, and the operations on the program control screen (operations only on models with the option).
7	Measurement Function Related Setup Operations Describes how to set the PV input of the measurement function and alarms (measurement alarms).
8	Operations for Changing the Displayed Contents Describes how to change the operating display of both the control function and the measurement function and the display format.
9	Data Save/Load Operations Describes how to write various data to the internal memory, how to save and load from the external storage medium, and the file operations on the external storage medium.
10	Computation and Report Function Related Operations (Only on Models with the Computation Function Option) Describes how to set and execute operations related to the computation function and report function of the computation function option.
11	Operations of Other Functions Describes the USER key, key lock, login/logout of key operation, log display, and remote input setting.
12	Troubleshooting Describes the error messages and the troubleshooting measures of the CX2000.
13	Maintenance Describes periodic inspection, calibration, and recommended replacement period for worn parts.
14	Specifications Describes the specifications of the CX2000.
Appendix	Describes the acquisition function of measured data to the internal memory, additional information on the computation and report functions, the ASCII file format, and initial settings.
Index	

Note

- This user's manual covers information regarding CX2000s that have a suffix code for language "-2" (English).
- For details on setting the displayed language, see *section 3.6*.

Conventions Used in This Manual

Unit

K..... Denotes “1024.” Example: 768 KB (file size)

k..... Denotes “1000.”

Safety Markings

The following markings are used in this manual.



Danger. Refer to corresponding location on the instrument.

This symbol appears on dangerous locations on the instrument which require special instructions for proper handling or use. The same symbol appears in the corresponding place in the manual to identify those instructions.

WARNING

Calls attention to actions or conditions that could cause serious injury or death to the user, and precautions that can be taken to prevent such occurrences.

CAUTION

Calls attentions to actions or conditions that could cause damage to the instrument or user’s data, and precautions that can be taken to prevent such occurrences.

Note

Calls attention to information that is important for proper operation of th instrument.

Symbols Used on Pages Describing Operating Procedures

On pages that describe the operating procedures in Chapter 3 through 11, the following symbols are used to distinguish the procedures from their explanations.

[]..... Indicates character strings that appear on the screen.
Example: [Space] soft key, [Volt]

Procedure

This subsection contains the operating procedure used to carry out the function described in the current section. All procedures are written with inexperienced users in mind; experienced users may not need to carry out all the steps.

Setup Items

Describes the details of the settings and the restrictions that exist with the operating procedure. It does not give a detailed explanation of the function. For details on the function, see chapter 1.

Revision History

Edition	Addition and Change to Functions
7	Added the contents of IM04L31A01-05E (the user’s manual describing changes to functions with version 3.02 or later) to the user’s manual, and discarded IM04L31A01-05E. Added an I/O terminal diagram. Added example expressions.

Contents

⚠ Safety Precautions	ii
Checking the Contents of the Package	iv
How to Use This Manual	vi

Chapter 1 Explanation of Functions

1.1 CX2000 Overview	1-1
1.2 Control Function Overview	1-2
1.3 Basic Settings of Control	1-16
1.4 PV Input Related Settings	1-22
1.5 Contact Input/Output Related Settings	1-26
1.6 Target Setpoint Related Settings	1-30
1.7 PID Parameter Settings	1-32
1.8 Control Output Suppression Settings	1-36
1.9 Settings for ON/OFF Control	1-38
1.10 Control Alarm Related Settings	1-39
1.11 Program Control Related Settings	1-41
1.12 Tuning	1-56
1.13 Measurement Function Overview	1-58
1.14 Measurement Function > Measurement Input Related Settings	1-60
1.15 Measurement Function > Measurement Alarm Related Settings	1-63
1.16 Display Function	1-68
1.17 Data Storage Function	1-89
1.18 Computation and Report Functions (Option)	1-94
1.19 Equations for Control Computation (Style Number S3 or Later)	1-98
1.20 Other Functions	1-99

Chapter 2 Installation and Wiring

2.1 Handling Precautions	2-1
2.2 Installation	2-2
⚠ 2.3 Wiring	2-5
⚠ 2.4 Connecting the Power Supply	2-21
⚠ 2.5 Connecting a Monitor to the VGA Output Terminal (/D5 Option)	2-22
⚠ 2.6 Transmitter Power Supply Wiring (/TPS4 Option)	2-23

Chapter 3 Names of Parts, Display Modes, and Common Operations

3.1 Names and Functions of Sections	3-1
3.2 Basic Key Operations	3-4
3.3 Setting the Date and Time	3-11
3.4 Setting the Brightness of the Display and the Backlight Saver Function	3-13
3.5 Initializing the Setup Data and Clearing the Internal Memory	3-14
3.6 Changing the Displayed Language	3-15
3.7 Changing the Time Zone	3-16
3.8 Inserting and Ejecting the External Storage Medium	3-17

Chapter 4 Control Function Related Setup Operations

4.1 Control > Control action, Input setting	4-1
4.2 Control > DI/DO/SW-registration/AUX (Alarm mode...)	4-5
4.3 Control > Output processing	4-11
4.4 Control > Relay	4-13

4.5	Control > Tuning setting	4-15	1
4.6	Control input range	4-17	
4.7	Control alarm	4-21	
4.8	Operation-related parameters/Zone PID	4-23	2
4.9	PID parameters	4-25	
4.10	Control group setting	4-27	
4.11	Ten-segment linearizer I/O	4-29	
4.12	Control Function Settings	4-31	3
4.13	Hysteresis (Alarm)	4-33	
4.14	DIO Operation Monitoring Function Settings (Style Number S3 or Later)	4-35	
4.15	DI/DO Label Settings (Style Number S3 or Later)	4-38	4
4.16	PV/SP Computation and Analog Retransmission Settings (Style Number S3 or Later)	4-39	
4.17	Logic Computation Settings (Style Number S3 or Later)	4-43	
4.18	Control Constant Settings (Style Number S3 or Later)	4-45	
4.19	Settings for Switching the Program Patterns Using Contact Inputs with BCD Codes (Version 3.20 or Later)	4-47	5

Chapter 5 Program Control Related Setup Operations

5.1	Program Control Related Setup Operations	5-1	6
5.2	Program parameter setting > Pattern initial setting	5-2	
5.3	Program parameter setting > Wait action setting	5-4	
5.4	Program parameter setting > Pattern start setting	5-5	7
5.5	Program parameter setting > Program pattern setting	5-6	
5.6	Program parameter setting > Event setting	5-8	
5.7	Program Pattern Settings > Hysteresis (PV Event)	5-10	8
5.8	Program parameter setting > Repeat action setting	5-11	
5.9	Event Output Settings	5-12	
5.10	AUX (Auto message, Display position)	5-14	
5.11	AUX (Event Group) Settings (Style Number S3 or Later)	5-16	9

Chapter 6 Operations during Control Operation

6.1	Operations on the Control Group Display (Switching Displayed Information and Control Operation Modes)	6-1	10
6.2	Switching Displays on the Overview Display	6-8	
6.3	Tuning Operation	6-9	
6.4	Operations on the Program Selection Display and Program Control Display (Only on Models with the Program Control Option)	6-12	11

Chapter 7 Measurement Function Related Setup Operations

7.1	Settings Related to Measurement Inputs	7-1	12
7.2	Settings Related to Measurement Alarms	7-6	
7.3	Setting the Temperature Unit	7-11	

Chapter 8 Operations for Changing the Displayed Contents

8.1	Using the Information Display (Alarm Summary, Message Summary, Memory Summary, and Control Summary)	8-1	14
8.2	Using the Four Screen Display	8-2	
8.3	Measurement Function > Measurement Group Setup Operation	8-3	
8.4	Measurement Function > Settings Related to Tag Display for Channels	8-5	
8.5	Measurement Function > Operations When Displaying Trend, Digital, and Bar Graph Displays	8-7	App
8.6	Measurement Function > Operations When Displaying the Overview	8-9	

8.7	Measurement Function > Operations When Displaying the Historical Trend	8-10
8.8	Measurement Function > Changing the Display Update Rate of the Trend Display	8-11
8.9	Measurement Function > Settings Related to Messages Displayed on the Trend Display and Write Operation	8-12
8.10	Measurement Function > Changing the Trip Line of the Trend Display	8-14
8.11	Measurement Function > Changing the Channel Display Color	8-16
8.12	Measurement Function > Changing the Zone Display of the Trend Display	8-18
8.13	Measurement Function > Setting the Scale Division, Bar Graph Base Position, Scale Position of Trend Displays	8-20
8.14	Measurement Function > Setting the Partial Expanded Display on the Trend Display ..	8-24
8.15	Measurement Function > Setting the Display Direction, Background Color, Waveform Line Width, Trip Line Width, Grid, and Scroll Time	8-26

Chapter 9 Data Save/Load Operations

9.1	Acquiring Measurement Data to the Internal Memory and Saving Data to the External Storage Medium	9-1
9.2	Saving Measured/Computed Data at Arbitrary Times (Manual Sample)	9-7
9.3	Saving and Loading Setup Data	9-8
9.4	Loading the Stored Display/Event Data (Historical Trend)	9-10
9.5	Managing Files and Checking the Free Space on the External Storage Medium	9-11
9.6	Saving the Screen Image Data	9-14
9.7	Clearing the Data in the Internal Memory	9-15

Chapter 10 Computation and Report Function Related Operations (Only on Models with the Computation Function Option)

10.1	Assigning Computation Channels and Setting Computing Equations, Constants and Tags	10-1
10.2	Starting, Stopping, and Resetting the Computation	10-4
10.3	Setting Computation Channel Alarms	10-5
10.4	Setting TLOG Computations	10-8
10.5	Setting the Rolling Average	10-11
10.6	Creating Reports	10-13
10.7	Starting/Stopping the Report Function	10-15

Chapter 11 Operations of Other Functions

11.1	USER Key Assignment and Operation	11-1
11.2	Key Lock	11-3
11.3	Key Operation Login/Logout	11-5
11.4	Displaying Logs (Checking Operations) and System Information Display (Checking the System Specifications)	11-8
11.5	Setting the Measurement Remote Input (/A6R option or /A4FR option)	11-11
11.6	Setting Whether or Not to Use the Batch Header (/BT1 option)	11-14
11.7	Setting the Batch Information (/BT1 option)	11-15
11.8	Setting the Batch Information (/BT1 option)	11-17

Chapter 12 Troubleshooting

12.1	Messages	12-1
12.2	Troubleshooting Flow Chart	12-11

Chapter 13 Maintenance

13.1	Periodic Inspection	13-1
13.2	Calibration	13-2
13.3	Replacement of Parts	13-4

Chapter 14 Specifications

14.1	Input Section Specifications	14-1
14.2	Control Function	14-3
14.3	Alarm Function	14-5
14.4	Display Function	14-6
14.5	Storage Function	14-8
14.6	Communication Functions	14-11
14.7	Options	14-13
14.8	General Specifications	14-17
14.9	Dimensional Drawings	14-21

Appendix

Appendix 1	Supplementary Explanation of the Acquisition of Display Data/Event Data to the Internal Memory	App-1
Appendix 2	Supplementary Explanation of the Computation Function	App-6
Appendix 3	Meaning and Syntax of Equations	App-10
Appendix 4	Additional Explanation of the Report Function	App-16
Appendix 5	Data Format of ASCII Files	App-19
Appendix 6	Initial Values	App-23
Appendix 7	Control Functon Blodk Diagram	App-40
Appendix 8	Explanation of Engineering Units (EU and EUS)	App-46
Appendix 9	Program Control Worksheets	App-47
Appendix 10	Expression Examples	App-51

Index

1
2
3
4
5
6
7
8
9
10
11
12
13
14
App
Index

1.1 CX2000 Overview

The CX2000 consists of a control function and a measurement function. The control function executes control through PID control and ON/OFF control. The measurement function displays and acquires measured data and control-output data.

Control Function

The CX2000 supports three control modes: single-loop control, cascade control, and loop control with PV switching or analog Retransmission. It can handle up to six loops of PID control. In addition, the UT Series controllers made by Yokogawa M&C Corporation can be connected and controlled simultaneously as external loops (16 loops max.). You can check the control status on the controller style and faceplate style displays and the hybrid style display that is a mixture of the two styles. Furthermore, the overview display allows monitoring of all control loops including external loops. In addition, the CX2000 provides auto-tuning of PID constants as well as manual tuning, which enables you to adjust the control parameters such as PID constants while checking the control status.

Measurement Function

In addition to the measured data for the control function, the CX2000 can acquire up to 20 channels of measured data. The data can be displayed as waveforms, numeric values, and bar graphs. The measured data along with the control data can be stored to a floppy disk, Zip disk, or ATA flash memory card using the built-in drive.

Conceptual Input/Output Diagram

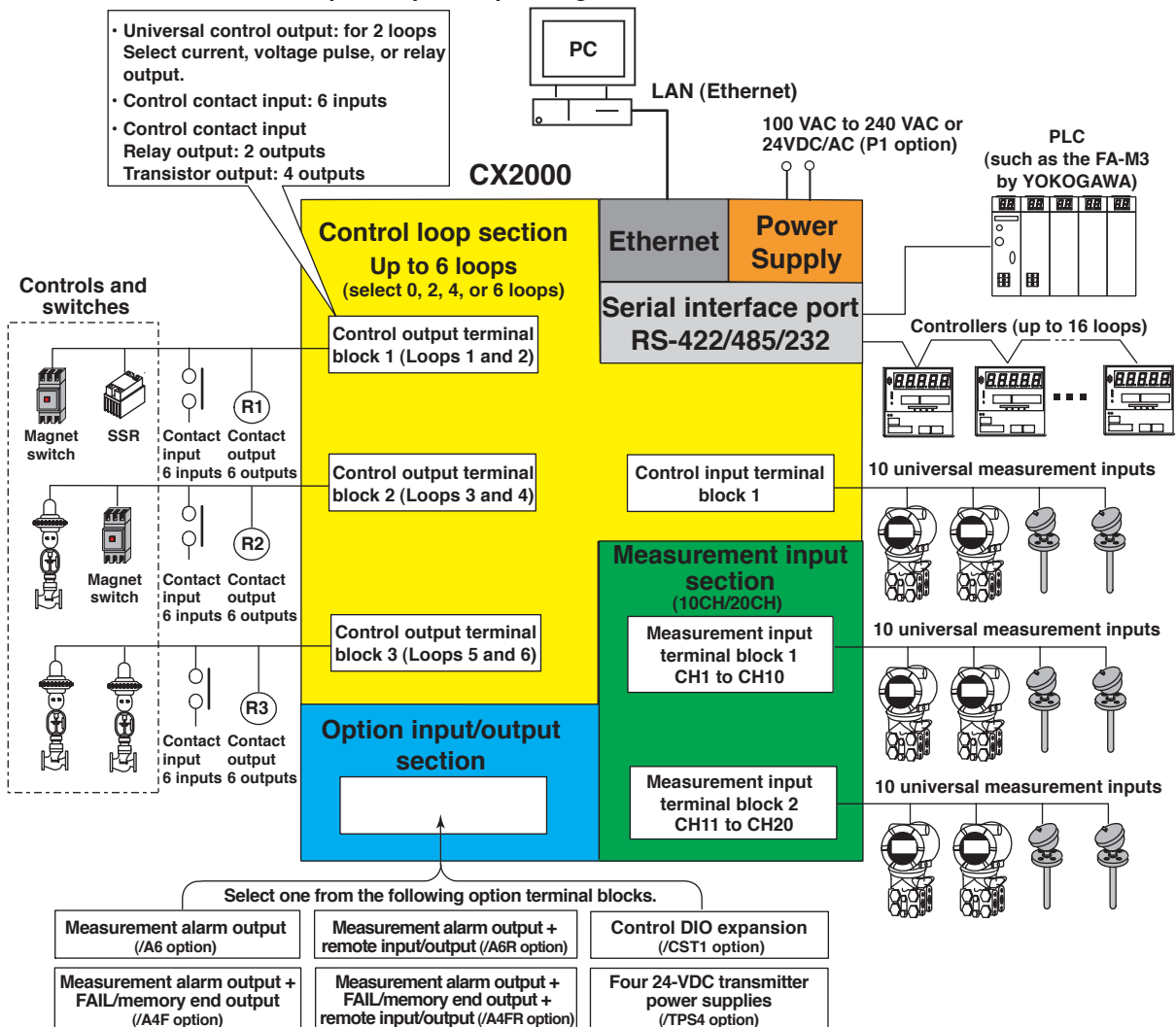

1.2 Control Function Overview

Control Signal Input/Output

As shown in the following figure, the CX2000 can control up to six loops (up to four or two loops on the 4- or dual-loop models, respectively).

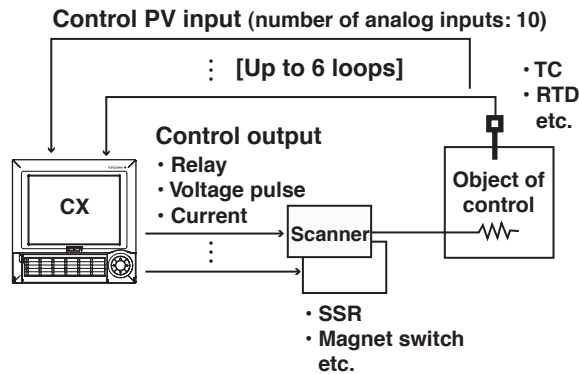

The UT Series controllers made by Yokogawa M&C Corporation can be connected via the serial interface and controlled simultaneously as external loops (16 loops max.) (see the *DAQSTATION CX1000/CX2000 Communication Interface User's Manual*).

Analog Input for Loop Control

PV input and remote setpoint input (RSP) are available as control signal inputs. You can select thermocouple, resistance temperature detector, standard signal, or DC voltage for both PV input and RSP input. The RSP input is used as a target setpoint (SP). There are 10 input terminals on the control input terminal block (5 input terminals for dual loop). When PV/SP computation is OFF, each input terminal is assigned depending on the number of loops used and the control mode (see *next page*) as shown in the figure below.

• 6 loops

PV, PV1, PV2: PV input, (RSP): RSP input
(not used during program control), □: unused terminal

LOOP4		LOOP6		LOOP3		LOOP2		LOOP5		LOOP1		
2	1	1	2	1	2	1	2	1	2	1	2	[Control mode setting]
(RSP)	PV	PV	(RSP)	PV	(RSP)	PV	(RSP)	PV	(RSP)	PV	(RSP)	← During single-loop control
□	PV	□	(RSP)	PV	□	PV	□	□	(RSP)	PV	□	← During cascade control
PV2	PV1	□	PV2	PV1	PV2	PV1	□	□	PV2	PV1	□	← During loop control with PV switching

• 4 loops

PV, PV1, PV2: PV input, (RSP): RSP input
(not used during program control), □: unused terminal

LOOP4		LOOP3			LOOP2		LOOP1			
2	1	3	2	1	2	1	3	2	1	[Control mode setting]
(RSP)	PV	□	(RSP)	PV	(RSP)	PV	□	(RSP)	PV	← During single-loop control
□	PV	□	(RSP)	PV	□	PV	□	(RSP)	PV	← During cascade control
PV2	PV1	(RSP)	PV2	PV1	PV2	PV1	(RSP)	PV2	PV1	← During loop control with PV switching

• 2 loops

PV, PV1, PV2: PV input, (RSP): RSP input
(not used during program control), □: unused terminal

					LOOP2		LOOP1			
□	□	□	□	□	2	1	3	2	1	[Control mode setting]
□	□	□	□	□	(RSP)	PV	□	(RSP)	PV	← During single-loop control
□	□	□	□	□	□	PV	□	(RSP)	PV	← During cascade control
□	□	□	□	□	PV2	PV1	(RSP)	PV2	PV1	← During loop control with PV switching

When PV/SP is ON, the numbers CI01, CI02, CI03, CI04, CI05, CI06, CI07, CI08, CI09, and CI010 are assigned to each control input terminal starting on the right as you face the terminals, and the PV/SP of each loop is the computed value.

You can apply scale conversion, bias, input filter, ten-segment linearizer bias, ten-segment linearizer approximation, and square-root computation on the control signal input. For thermocouple inputs, you can set reference junction compensation. In addition, ratio setting can be specified against RSP inputs.

Control Signal Output

The terminal provides universal output. A single control output terminal block can control two loops (except cascade control which uses two loops for one control). The following types of control output can be selected.

- **PID control output**

- Time proportional PID relay contact output: Outputs ON/OFF signals with a pulse width that is proportional to the time as relay contact signals according to the computed PID value.
- Time proportional PID voltage pulse output: Outputs ON/OFF signals with a pulse width that is proportional to the time as voltages according to the computed PID value.
- Current output (continuous PID control output): Continuously outputs a current (analog signal) that is proportional to the computed PID value.
- On/off control relay contact output: Outputs on/off control relay contact signals according to the polarity (positive/negative) of the deviation between the SP and the PV.

- **Analog Retransmission**

Outputs the specified computed result, not the computed PID value.

Control Methods

PID control and ON/OFF control are available. The following control modes can be selected for both PID control and ON/OFF control.

Control Mode

In PID control, the following three control modes are available in relation to the PV input selection.

- **Single-loop control**

Basic control consisting of a single system of controller CPU.

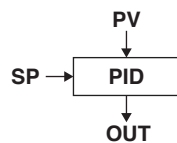

- **Cascade control**

Control consisting of two systems of controller CPUs that use the primary control output as the secondary control SP.

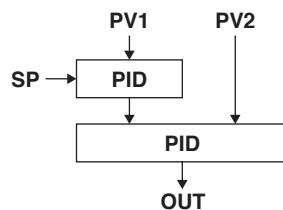

- **Loop control with PV switching**

Single-loop control that is switched between two PV inputs (PV1 and PV2) according to a specified condition.

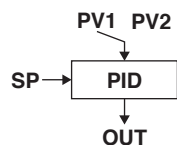

In PID control, you can also select the PID control mode.

PID Control Mode

Depending on the desired operation at the time the SP is changed, you can select the PID control mode from below. The selections between the PV derivative type and deviation derivative type as well as the presence or absence of the control output bumps are automatically made according to the PID control mode and operation mode (fixed-point control or program control).

1.2 Control Function Overview

- **Standard PID control**

Controlled so that the control output reaches the new SP quickly after the SP is changed.

PV derivative type PID (with output bump)

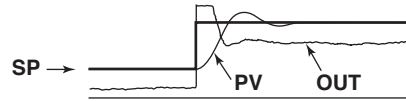

Deviation derivative type PID (with output bump)

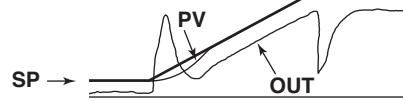

- **Fixed-point control**

Select this mode if you wish to avoid the control OUT from reacting sensitively to the SP change causing a disturbance in the control such as in the case with a continuous fixed-point control.

PV derivative type PID (without output bump)

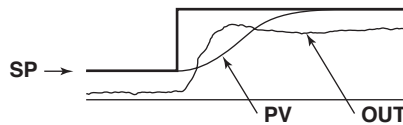

PV derivative type PID (with output bump)

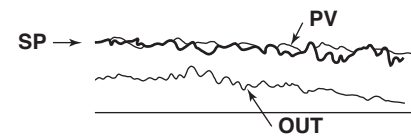

Control Parameters

The following control parameters are available. For each group, you can enter up to eight sets of SPs and PID parameters as underlined below.

SP, PID constant, control output limiter, ON/OFF of the shutdown function, manual reset value, relay hysteresis, control action direction, preset output, SP tracking, PV tracking, setpoint limiter, output velocity limiter, auto/manual switching of the over-integration prevention function (anti-reset windup), ON/OFF of the control output suppression function, and SP ramp-rate.

PID Selection Method

The following two methods are available.

- **Target setpoint selection method**

A group (up to 8 groups) consisting of a SP and PID parameters is registered to a PID number (SP number). By specifying the SP number using keys on the front panel, external contact input, or via communications, the SP and PID parameters are switched.

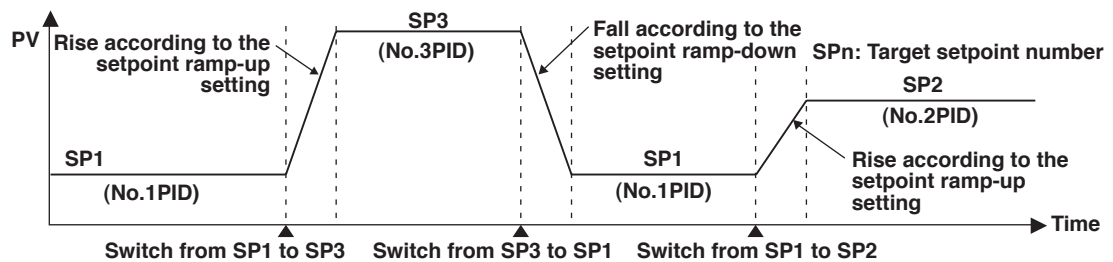

- **Zone PID method**

The measurement span is divided into a maximum of seven zones using reference points. The optimum PID constant is preassigned to each zone, and the PID constant (in actuality, other control parameters that are registered using the PID number are included) is automatically switched according to the PV. This method is suited for controlling equipment such as reactors in which the chemical reaction gain varies depending on the temperature.

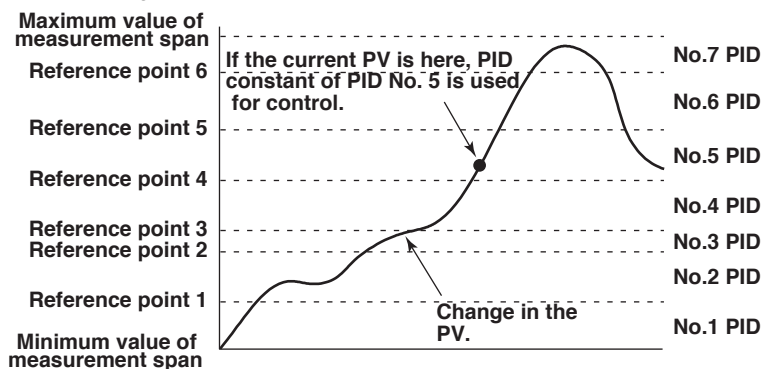

Note

- When performing program control operation on models with the program control option, you will select between segment PID method (zone PID selection OFF) and zone PID method.
- For a description on auto tuning, which automatically sets the optimum PID constant, see *section 1.12, "Tuning."*

Alarm Output

When the control action status matches the preset status (up to 4 points per loop), the CX2000 can output a relay contact signal from the control output terminal block/DIO expansion terminal block, and output it to the internal switches. Also you can display the alarm occurrence status on the screen. In relay contact output or output to the internal switches, you can select and assign the type of alarm you wish to output at each output terminal of the control output terminal block, the control DIO extension terminal block, or internal switches.

Alarm Type

You can select the alarm type from below. For a detailed explanation on each alarm output, see *section 1.10, "Control Alarm Related Settings."*

PV high-limit alarm, PV low-limit alarm, deviation high-limit alarm, deviation low-limit alarm, deviation high & low limit alarm, deviation within high & low limits alarm, SP high-limit alarm, SP low-limit alarm, output high-limit alarm, and output low-limit alarm.

Alarm Hysteresis

You can set a hysteresis to the setpoints used in the activation and releasing of the alarm.

Example of PV high limit alarm

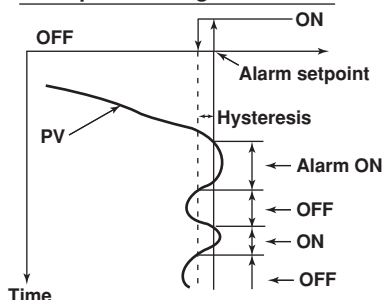

Alarm Standby

You can put the alarm output on standby at the initial stage of control operation until the PV input reaches the SP.

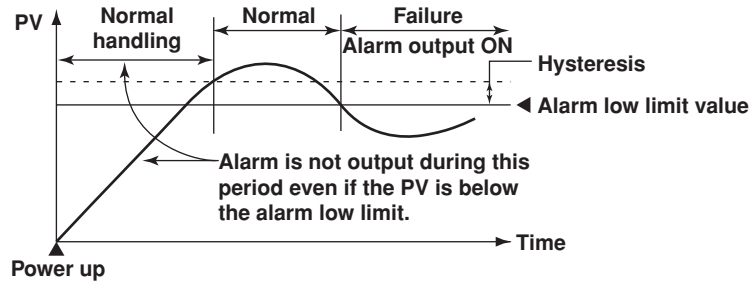

Alarm Mode

You can set the condition for disabling the alarm output (such as when the operation is stopped).

FAIL Output/Self Diagnosis Output

In addition to the alarm output described above, the following relay contact signal for failure detection can be output from the control output terminal block.

- **FAIL output**
Output when a failure is detected in the CX2000 CPU. When a failure is detected, the CX2000 is put in the following condition.
Control: Stopped (preset output if in the middle of operation, control output is off or 0% when power is turned ON)
- **Self diagnosis output**
Output when an input burnout, A/D converter failure, or RJC failure occurs. If an input burnout or A/D converter failure is detected, the control output is set to the preset output value. For RJC, PID control continues as though RJC is 0 °C.

Control Operation Mode

The following control operation switching is available. The control operation can be switched using keys on the CX2000 control group display (see page 1-12), using contact inputs, or via communications. For a description of the control operation modes on models with the program control option, see “Program Control” in the next section. The control function block diagram in the explanation below is a simplified one. For a detailed control function block diagram for each control mode, see appendix 7.

Switching between Remote (REM) and Local (LOC)

Select whether control is executed using the SPs set on the CX2000 or using the external analog signal (RSP) as the SP.

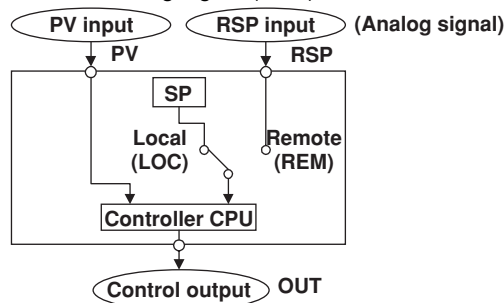

Switching between Auto (AUT), Manual (MAN), and Cascade (CAS)

When set to auto, the control output value (OUT) is computed from the deviation between the PV input and the SP. When set to manual, the control output value (OUT) that is set manually is used rather than the computed control output value (OUT). Switching to “cascade (CAS)” is possible only when the control mode is set to “cascade control.” In cascade control, the primary PID control output is used as the SP of the secondary PID control.

Switching between Run (RUN) and Stop (STP)

When the operation is stopped, the control output value (OUT) is set to the preset value.

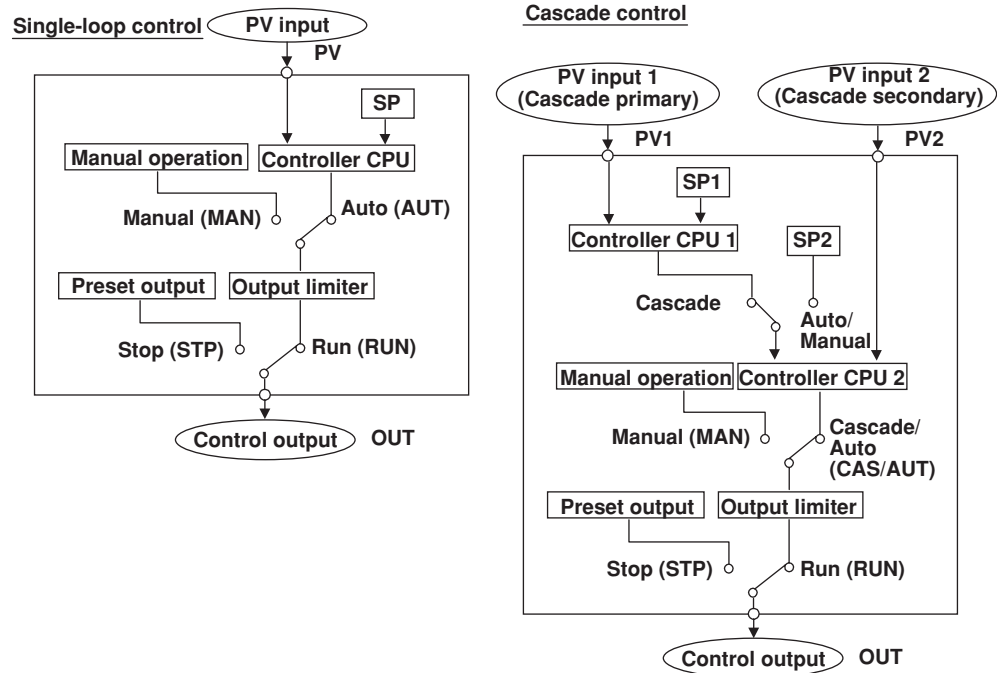
**Enabling/Disabling Auto-Tuning**

In PID control, the optimum PID constant is set automatically when auto-tuning (see page 1-52) is performed. Auto-tuning is possible only during auto operation.

Contact Input

Contact input can be used to carry out operations such as running/stopping operation, switching operation modes, changing SPs, switching PV inputs (during loop control with PV switching). For a description on the possible operations, see "Contact Input Information Registration" on page 1-24.

PV/SP Computation (Style Number S3 or Later)

You can use the specified computed result as PV or SP. When PV/SP computation is ON, you can set the control analog input terminals to CI01-CI10, and set the range for each channel.

The SP is active when the control operation mode is Remote. You can also use the control output value in the equation. The constants that can be used are separate from the computation function (W01-W36). When a computation error occurs, you can treat the computed result as an overrange or underrange. Computation is performed in synchronization with the control interval.

Analog Retransmission (Style Number S3 or Later)

Output comes from the control output channels per the results of the specified equation. The computed result is converted to a percentage of the output span (ranging from 0.0% for the lower limit of the output span to 100.0% for the upper limit), and then outputs according to the output format below. The output interval is the same as the control output interval.

- Time proportional relay contact output: Outputs an ON/OFF signal having a pulse width proportional to the time as relay contact point signal according to the computed values.
- Time proportional pulse output: Output an ON/OFF signal having a pulse width proportional to the time as voltage according to the computed values.
- Current output: Continuously output a current (analog signal) proportional to the computed PID values.

Note

- The output value while initialization occurs after turning the power ON or OFF is 0 mA or 0 V.
- The output value while in setup mode or when closing setup mode and switching to operation mode is 0 mA or 0 V.
- Analog retransmission is handled the same as when control mode is OFF. Control functions such as upper/lower limit of output value and preset output are not supported.

The following is a block diagram of analog retransmission:

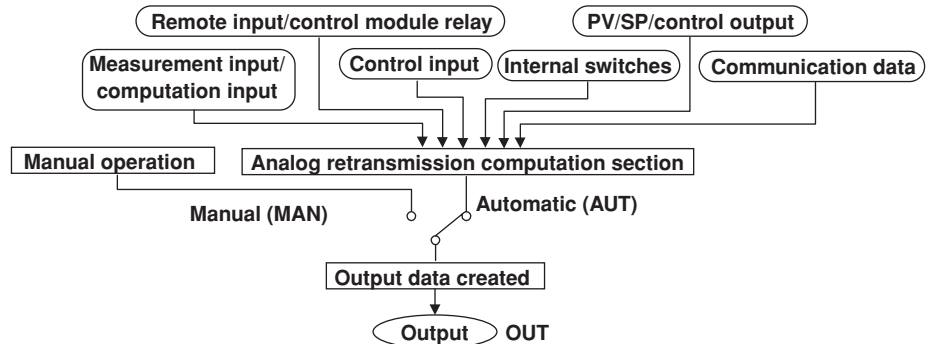

The order of processing for PID computation and analog retransmission is as follows:

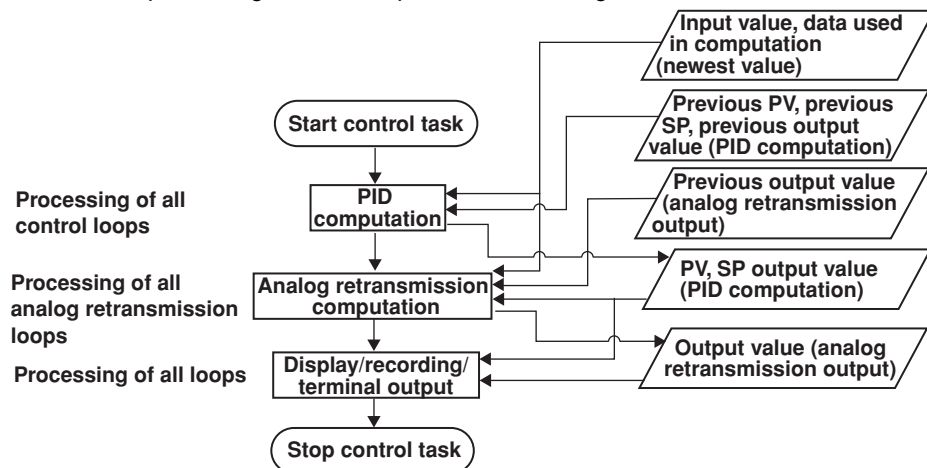

Data that can be used in the analog retransmission equation are as follows:

- Measured input data, measured computation data, internal/external control data, and communication input data.
- Constants (constants used in measurement computations can not be used)
- Control input data
- Control output module, expansion module DIO, and remote input for measurement
- Internal switches

Computation Error

You can specify the output method when a computation error occurs, such as when an overrange occurs on the computed results of analog retransmission.

Over: 105% of span

Under: -5% of span

Display/Recording of Analog Retransmission

The output value of analog retransmission is displayed/recorded as the OUT value of the loop specified for analog retransmission. PV and SP are not displayed or recorded.

Internal Switches (Style Number S3 or Later)

Internal switches are software switches that are not output externally, and are used only for internal processing. The switches have the following uses.

- The same output destination as the output relay
Control alarm, measurement alarm, measurement computation alarm, time event, PV event, program pattern end signal, logic computation output.
- DIO operation monitoring function
- Use of computation data in the PV/SP computation and the analog retransmission equation
- Assignment of actions to changes in the status of the internal switches
- Reads the operation ON/OFF and internal switch statuses using the communication function.

The status of the internal switches is "nonhold."

DIO Operation Monitoring Function (Style Number S3 or Later)

Internal Switches and DIO Operation Monitoring Function

Since the internal switches are used exclusively for internal processing, the status of the switches cannot be confirmed externally. With the DIO operation monitoring function, you can output the status of the internal switches by assigning a DO to the internal switch. You can output the ON and OFF statuses of the internal switches to separate DOs. Also, you can switch between Auto and Manual operation modes. When in Auto mode, the status of the internal switches is output. When in Manual mode, you can manually switch between DO ON(1) and OFF (0). Internal switch output has priority over alarm output and event output. If the same DO is assigned to an internal switch and an alarm output, alarms cannot be output.

When DO01 is assigned to SW01

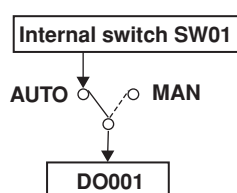

When DO003 is assigned to the ON signal of SW02, and DO004 is assigned to the OFF signal

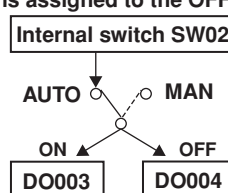

In the above cases, even if D001, DO003, and DO004 are specified for alarm output, the alarm signal is not output. However, FAIL and self diagnosis output take priority over the internal switch status output.

Program Control (Optional Function)

This function is used to ramp-up or ramp-down the SP according to a program pattern. You can set multiple program patterns (up to 4 on the /PG1 option and up to 30 on the PG/2 option) and switch among them according to the operating condition. A program pattern consists of multiple program segments. With style number S3 or later, you can execute a program pattern while a separate program pattern is executing as long as the operating loops do not overlap. There are two methods in selecting the PID constant in program control. One is the “segment PID method” in which the PID constant is switched every segment according to the program pattern setting; the other is the “zone PID method” in which the PID constant is automatically switched according to the PV. The “segment PID method” is used when a different PID constant is required in the same PV region when the temperature is rising and when the temperature is falling.

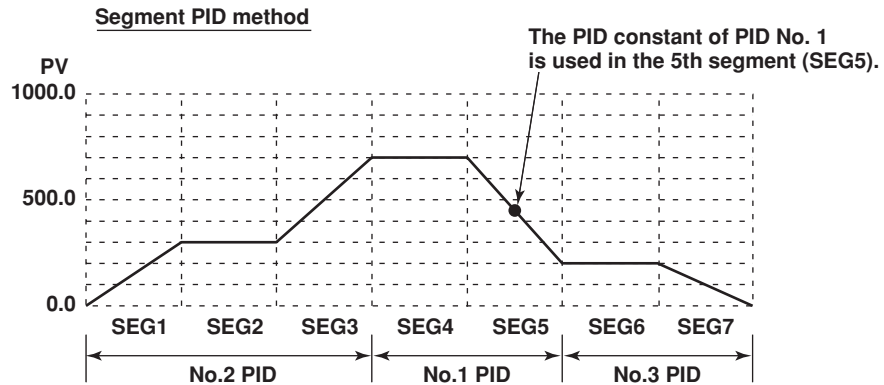

Setting the Operation for Program Control

Settings include the number of repetitions of the program pattern (repeat function), delay function (wait function) for the case when the PV cannot follow up the SP, and alarm output/event output assignments (contact output can be assigned) according to the program progression.

Operation Mode during Program Control

The following 4 types of operation modes are available.

- Program operation mode
Condition in which control is carried out according to the program pattern.
- Hold operation mode
Condition in which the change in the SP according to the program pattern is forcibly paused through key operation or other factors.
- Reset mode
Condition in which program operation of all loops is stopped. All event outputs are cleared (off).
- Local operation mode
If you switch to local operation mode even during program control, fixed-operation is performed according to the SP set locally.

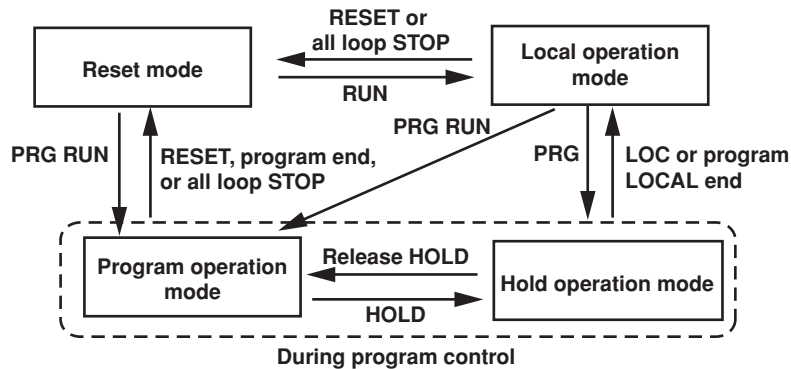

Since the remote input cannot be used for the SP during program control, there is no remote/local switching operation.

Flow of Setup Procedure

Below is a standard flow of setup procedure in executing control for the first time using auto operation.

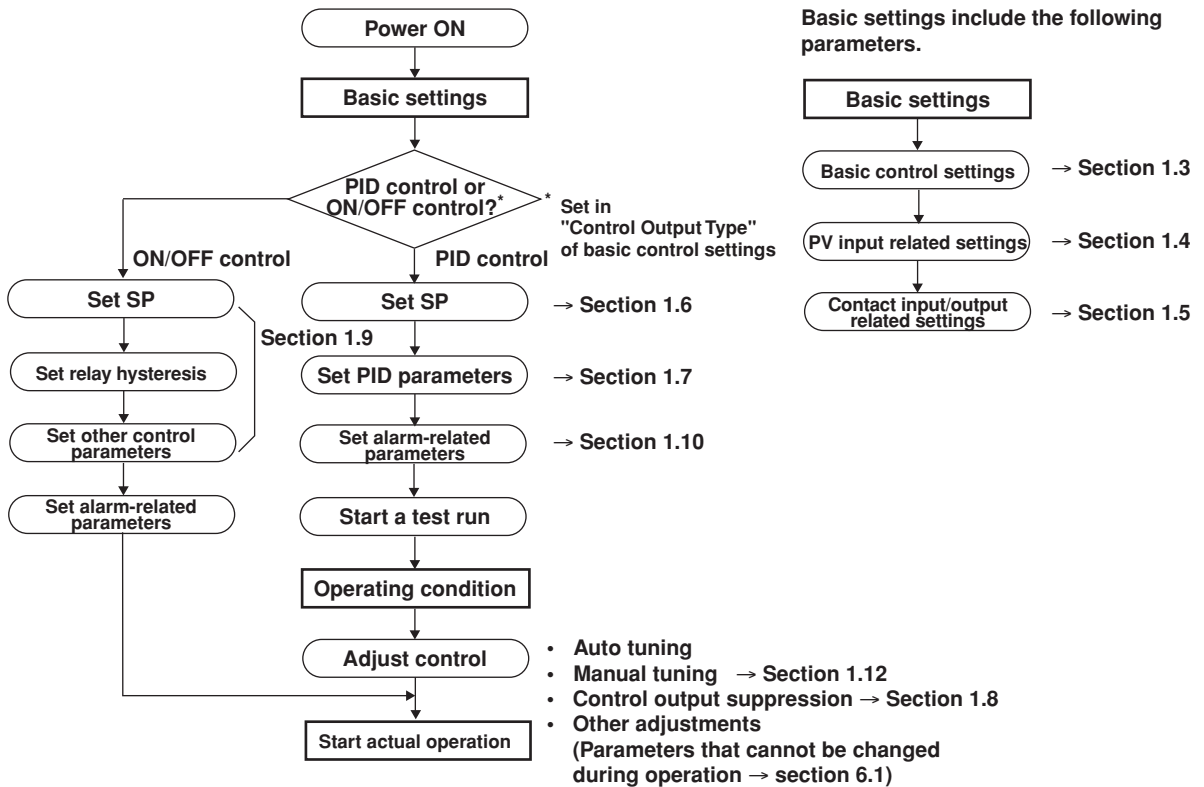

When using program control, set the items that include “Program control: On” in “Basic control settings” indicated above. Then, carry out the following settings in addition to “Target setpoint/PID parameter settings.”

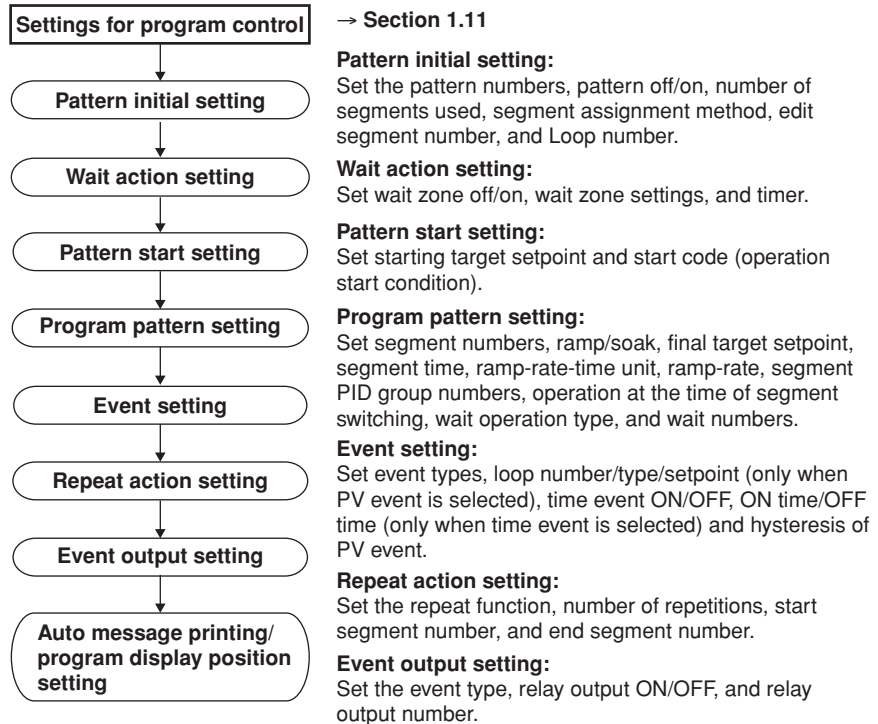

Switching Displays

Control-related settings are entered in basic setting mode and control setting mode. In addition, settings common to control and measurement are entered in the common and measurement setting mode.

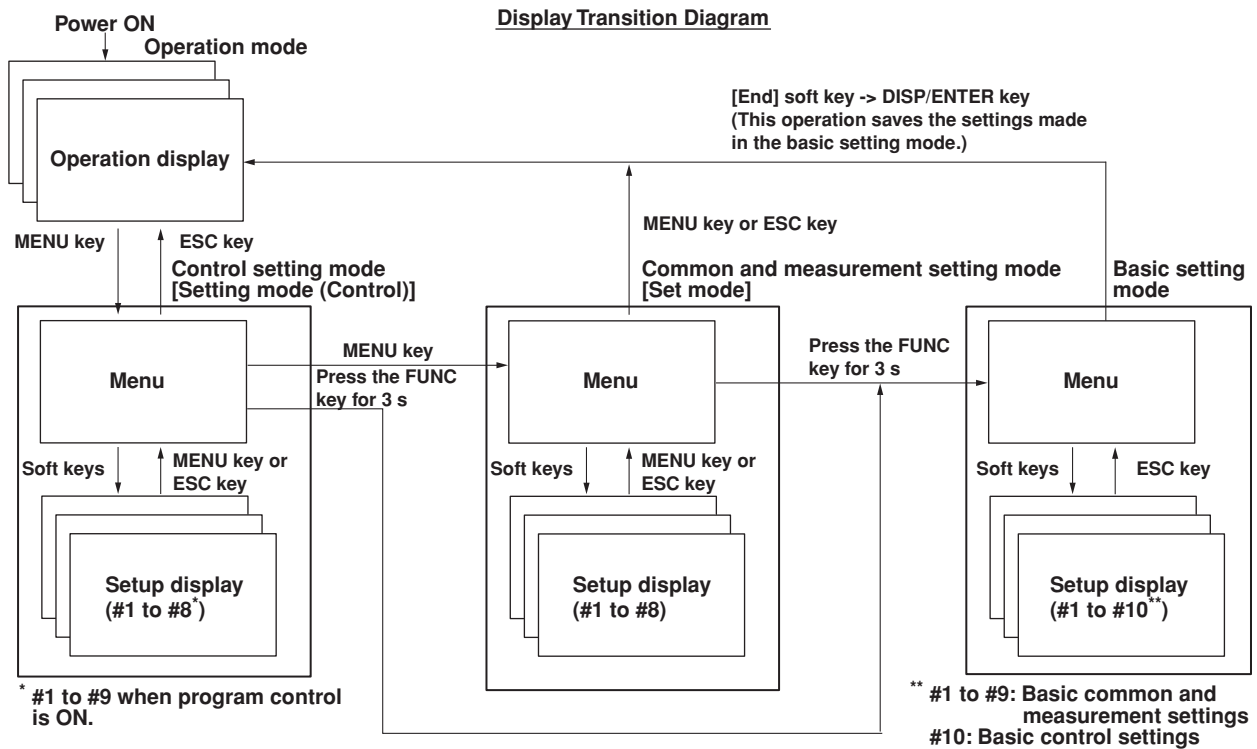

Basic Control Setup Items in Basic Setting Mode

- #1 Control action, Input setting
 PID number, control period, zone PID, restart mode, restart mode (program) (only on models with the control option), initial PID, 6/4 loop select (only on models with six loops), auto tuning, control mode, method (only during loop control with PV switching), program control ON/OFF (only on models with the program control option), PID control mode, burnout, and RJC.
- #2 Contact input registration/AUX (Alarm mode)
 Contact input registration, remote setting, alarm mode, and SP number selection source.
- #3 Output processing
 Control output, cycle time, and analog-output type
- #4 Relay
 FAIL ON/OFF, self diagnosis ON/OFF, and relay action/behavior (energize/de-energize, hold/nonhold)
- #5 Tuning setting
 Tuning item selection
- #6 External loop setting (For details on the settings, see the *DAQSTATION CX1000/CX2000 Communication Interface User's Manual*.)

Setup Items in the Control Setting Mode

- #1 Control input range
 Input type, mode, type, range, span, scale, unit, square root, low-cut, bias, filter, and ratio.
- #2 Control alarm
 Type, standby, relay output ON/OFF, and alarm value

#3 Operation-related parameters/Zone PID

Suppressing function, ramp-rate-time unit, SP ramp-down-rate/SP ramp-up-rate, tag, tag comment, reference point (when zone PID is selected), switching hysteresis (when zone PID is selected), and reference deviation (when zone PID is selected).

#4 PID parameters

SP, PID constant, output limit, shutdown ON/OFF, manual reset, relay hysteresis (only during ON/OFF control), reverse/direct, and preset output.

#5 Control group setting

Group name, kind (internal loop/external loop/measurement channel), and number.

#6 Ten-segment linearizer I/O

Input type, mode, and biasing or approximation input/output values.

#7 Program control parameters (only when program control is ON)**#1 Program parameter setting**

#1 Pattern initial setting

#2 Wait action setting

#3 Pattern start setting

#4 Program pattern setting

#5 Event setting

#6 Event output setting

#7 Hysteresis (PV event)

#8 Repeat action setting

#2 AUX (Auto message, Display position)

Auto message for program Run/Reset, Program display position, and Auto change to program run display.

#3 AUX (Event group)**#8 Detailed setting (“#7” when program control is OFF)****#1 Control function**

SP tracking, PV tracking, SP limiter, output velocity limiter, and anti-reset windup auto/manual.

#2 Hysteresis (Alarm)**#3 DIO monitor and operation setting****#4 DI/DO label setting****#9 Control math setting (“#8” when program control is OFF)****#1 PV/SP math, Retransmission**

#2 Logic math (#1 when both PV/SP computation and analog retransmission are inactive.)

#3 Constant (#2 when both PV/SP computation and analog retransmission are inactive.)

Control Operation Display

In operation mode, the following control operation displays can be shown.

- Control group display

This display is used to monitor the control status of multiple loops simultaneously including external loops. You can select from three display styles as shown in the display example in the figure below. If you include the measurement channels for the measurement function in the group, you can also monitor the measured values on the measurement channels at the same time on this display.

- Tuning display

This display is used to optimize (tune) the control parameters such as PID constants.

- Overview display

This display is used to monitor the alarm status of all control loops.

1.2 Control Function Overview

- DI/DO status display
Displays the ON/OFF status of the current contact input (DI) and contact output (DO).
- Internal switch status display
Displays the current ON/OFF status of the internal switches.
- Control action summary display
Displays a log of control actions such as operation run/stop and auto/manual operation switching.

On models with the program control function option, additional displays are available such as 1) the program control display, which can show the pattern and current PV accumulated on the screen during program operation and 2) the program event summary display, which shows a log of time events and PV events that occurred during program operation.

Displays common with the measurement function include: 1) the alarm summary display, which shows a log of alarm occurrence status and 2) the memory summary display, which shows the file information of the internal memory.

In addition, the values of PV, SP, and OUT can be assigned to channels, and the trends of these channels can be displayed along with the trends of measurement channels on the trend display of the measurement function.

Display Examples

- Control group display



Controller style



Faceplate style



Hybrid style

- Tuning display

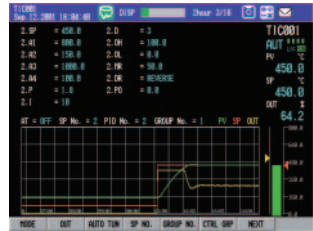

Tuning display

- Overview display

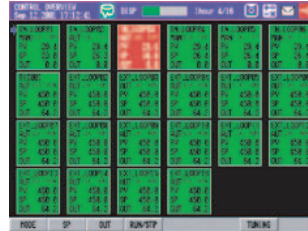

Overview display

- DI/DO status display



DI/DO status display

- Control operation summary display

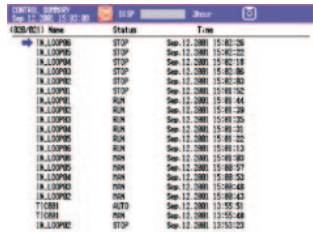

- Internal switch status display



Internal switch status display

- Program control display

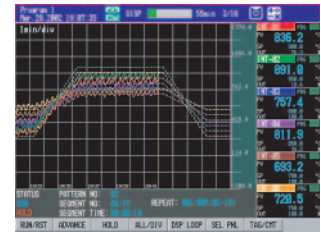

Program control display

Saving Data

Acquisition to the Internal Memory

Along with the measurement data, the data of SPs, PVs and OUT, and event information for control are acquired to the internal memory.

Saving Data to the External Storage Medium

You can save the data acquired in the internal memory to an external storage medium (floppy disk, Zip disk, or ATA flash memory card).

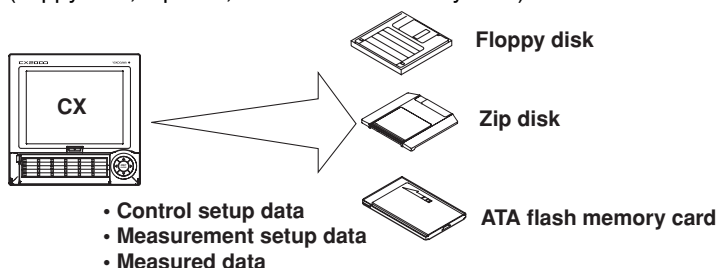

Communications

The following communications functions are available. For a description on the handling of the communications function and the software "DAQSTANDARD for CX" that comes with the package, see the respective manuals.

Communications with Controllers

The CX2000 can communicate with UT Series Controllers made by Yokogawa M&C Corporation to transmit/receive control parameters and receive PV data. Up to 16 external loops can be constructed.

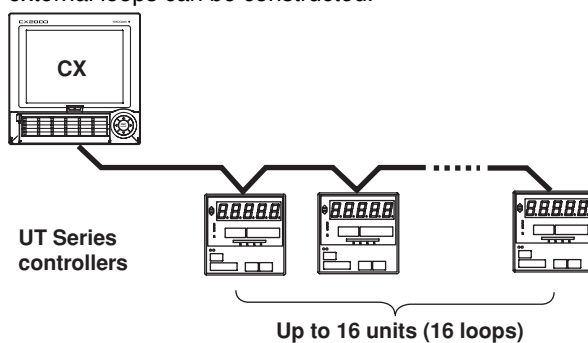

Communications with PLCs

The CX2000 can carry out ladder communications between PLCs (sequencers).

PLCs (such as the FA-M3 by YOKOGAWA)

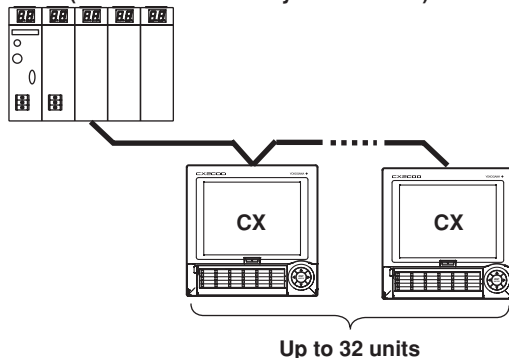

Communications with PCs

The CX2000 can communicate with PCs.

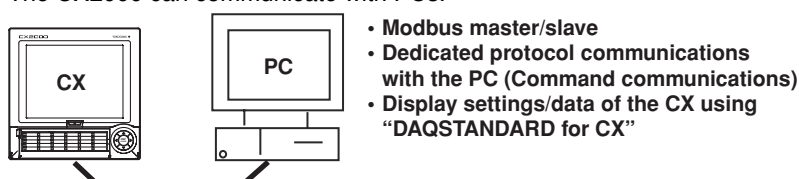

1.3 Basic Settings of Control

PID Group Number

You can set up to eight groups of control parameters (“PID parameters” on the setting display) that you wish to change collectively through control. You set the number of groups to be used from 1 to 8. For example, if you set a value of 4, the selectable PID numbers will be 1 through 4. The parameters that are included in a single control parameter group vary depending on the control method (“Control output” in the settings).

During PID control: SP, PID constant, output lower/upper limit, shutdown ON/OFF (only when outputting 4-20 mA of current), manual reset, reverse/direct, and preset output

During ON/OFF control: SP, relay hysteresis, reverse/direct, and preset output

Control Period

The following control periods can be selected:

250 ms (initial value), 500 ms, and 1 s.

The control period is common to all loops. When the A/D integral time is set to 100 ms, the control period is fixed to 1 s.

The scan interval of control PV input is the same as the control period.

PID Selection Method (Zone PID ON/OFF)

Select either one from below. When program control is ON on models with the program control option, the selection is between the segment PID method (zone PID OFF) and the zone PID method.

- **Target setpoint selection method (zone PID: OFF) (initial value)**

In the target setpoint selection method, the operator can switch up to 8 SPs as necessary.

There are two methods in switching the SPs. One method is to specify the SP number (SPs are registered to PID numbers (= SP numbers) along with PID constants and other parameters) using keys on the front panel. The other is to use external contact input or communications. The SP can be switched at any time. During switching, the setpoint ramp-up-rate or setpoint ramp-down-rate setting is activated. In addition, when a switch is made, control computation is performed using the PID constant group that corresponds to the SP at that point.

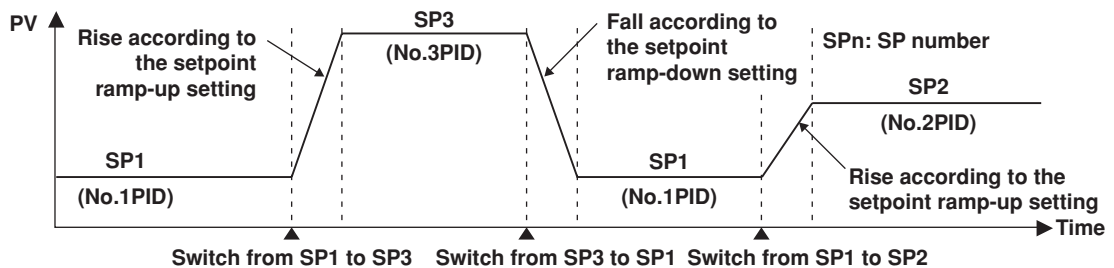

- **Zone PID method**

In the zone PID method, the measurement span is divided into a maximum of seven zones using reference points. The optimum PID constant is preassigned to each zone, and the PID constant (in actuality, other control parameters that are registered using the PID number are included) is automatically switched according to the PV.

The number of reference points that can be specified is “PID group number – 2.” As shown in the figure on the next page, if the PID group number is 7, the number of reference points is 5. If the number of reference points is 5, there are 6 zones. For example, if zones 1 through 6 correspond to PID numbers 1 through 6 and if the PV is within the zones of reference points 3 and 4, the control parameters of PID number 4 are selected. The control parameters of PID number 7, which cannot be assigned to a zone, are selected when the deviation between the SP and PV becomes greater than the preset reference deviation.

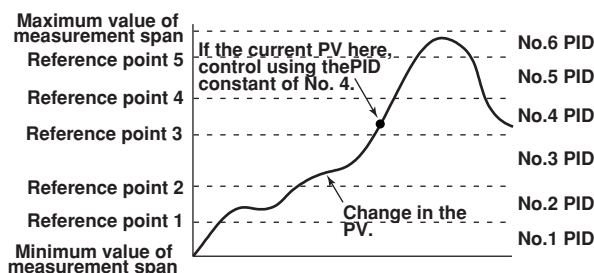

Restart and Restart for Program Control

Select how the CX2000 is to behave when an extended power failure occurs during control operation (power failure period of 5 s or more) and the power recovers.

- **Continue** (initial setting):
Continue the operation before the power failure occurred.
- **Manual operation**:
Start from the manual operation condition.
- **Auto operation** (only during fixed-point operation):
Auto operation by continuing the operation before the power failure occurred.
- **Reset** (only during program operation):
Stop the program operation.

Note

If the duration of the power failure is less than or equal to 2 s (a short power disruption), the operation before the disruption continues. If the duration is between 2 to 5 s, the behavior for a short power disruption or an extended power failure is carried out depending on the condition.

Initial PID

Select whether the initial PID constant in PID parameter settings (see *page 1-32*) is optimized to temperature control, pressure control, or flow control. Below are the initial values of PID constants.

Initial values for temperature: P = 5.0%, I = 240 s, and D = 60 s.

Initial values for pressure/flow: P = 120.0%, I = 20 s, and D = 0 s.

6/4 Loop Select (only on 6-loop models)

Select whether the number of loops used is 6 (factory default setting) or 4. If set to 6 loops, a limitation occurs in the assignment of analog control input signal (see "Difference in the Control Input Configuration According to the 6/4 Loop Selection and Control Mode" on the *next page*).

Control Mode

The following three control modes are available. The mode is selected for each control loop.

• Single-loop control

Basic control consisting of a single system of controller CPU.

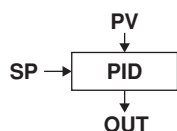

• Cascade control

Control consisting of two systems of controller CPUs that uses the primary control output as the secondary control SP. Continuous PID control is only possible for primary control.

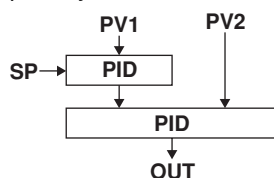

1.3 Basic Settings of Control

• **Loop control with PV switching**

Single-loop control that switches between two PV inputs (PV1 and PV2) according to the following conditions.

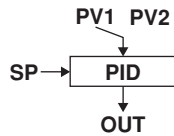

Input Switching Condition ([Method] on the setting display)

- Auto switching according to the PV range ([Range] on the setting display)
Switches PV inputs (PV1 and PV2) automatically according to the preset “PV switching low-limit” and “PV switching high-limit” as shown in the following figure. However, PV1 must be less than PV2.

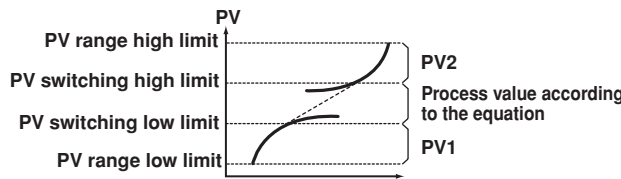

The PV value is computed using the following equation when “PV switching lower limit < PV1 ≤ PV switching upper limit” and “PV switching lower limit ≤ PV2 < PV switching upper limit.”

$$\text{Process value} = \left(1 - \frac{\text{PV input 1} - \text{PV switching low limit}}{\text{PV switching high limit} - \text{PV switching low limit}}\right) \times \text{PV input 1} + \left(\frac{\text{PV input 1} - \text{PV switching low limit}}{\text{PV switching high limit} - \text{PV switching low limit}}\right) \times \text{PV input 2}$$

- Auto switching according to the PV switching upper limit ([PVHigh] on the setting display)
The preset “PV switching upper limit” and PV1 are compared. Auto switching is performed according to the following conditions. The switching hysteresis is approximately 0.5% of the PV range span.
When PV1 ≤ PV switching upper value: Switch to PV1
When PV1 > PV switching upper value: Switch to PV2
- Switching through control input ([Signal] on the setting display)
Input is switched using “PV switching (loops 1 to 4)” (see page 1-27) as follows:
Contact input is OFF: Switch to PV1. Contact input is ON: Switch to PV2.

Analog Retransmission

Outputs the specified computed result instead of the computed PID value from the control output terminal. In control setting mode, you can set the equation, output span, unit, and method of processing computation errors for the loop specified for analog retransmission. Unlike the 3 control modes above, control functions such as upper/lower output value and preset output are not supported.

Difference in the Control Input Configuration According to the 6/4 Loop Selection and Control Mode (when PV/SP computation is OFF)

The input signal assignments of each terminal of the analog control input block vary depending on the 6/4 loop selection and the selected control mode as shown in the figure below. If set to 6 loops, the control mode of the 5th and 6th loops can only be set to single-loop control.

• **6 loops**

PV, PV1, PV2: PV input, (RSP): RSP input
(not used during program control), □: unused terminal

LOOP4		LOOP6		LOOP3		LOOP2		LOOP5		LOOP1		[Control mode setting]
2	1	1	2	1	2	1	1	2	1			
(RSP)	PV	PV	(RSP)	PV	(RSP)	PV	PV	PV	(RSP)	PV	← During single-loop control	
□	PV	□	(RSP)	PV	□	PV	□	□	(RSP)	PV	← During cascade control	
PV2	PV1	□	PV2	PV1	PV2	PV1	□	□	PV2	PV1	← During loop control with PV switching	

• 4 loops

PV, PV1, PV2: PV input, (RSP): RSP input

(not used during program control), □: unused terminal

LOOP4			LOOP3			LOOP2			LOOP1		
2	1	3	2	1	2	1	3	2	1		
(RSP)	PV	□	(RSP)	PV	(RSP)	PV	□	(RSP)	PV	← [Control mode setting]	
□	PV	□	(RSP)	PV	□	PV	□	(RSP)	PV	← During single-loop control	
PV2	PV1	(RSP)	PV2	PV1	PV2	PV1	(RSP)	PV2	PV1	← During cascade control	
										← During loop control with PV switching	

PV When PV/SP Computation is ON

When the PV/SP computation function is ON, PV is the specified computed result.

Therefore, the input signals from each terminal are not assigned to the control analog terminal block as the PV of each loop.

Program Control ON/OFF (only on models with the program control option)

Select whether to use the program control function. For a description on the settings for program control, see section 1.11, "Program Control Related Settings."

PID Control Mode

There are two PID control modes: standard PID control mode and fixed-point control mode. To control the output so that the PV reaches the new SP quickly after the SP is changed, select "standard PID control mode." To perform a continuous fixed-point control, select "fixed-point control." As shown in the figure below, the control behavior varies depending on the selected PID control mode. There are two control methods: PV derivative type PID control method and deviation derivative type PID control method. As shown in the figure below, the control method is automatically selected. In addition, the presence or absence of the control output bump at the point of change of the SP is automatically selected. When performing program control in standard PID control mode on models with the program control option, deviation derivative type PID control is used during operation (except during hold and soak) and on the secondary loop of cascade control. For all other cases, PV derivative type PID control is used.

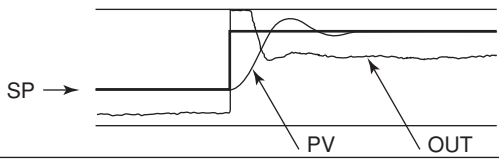
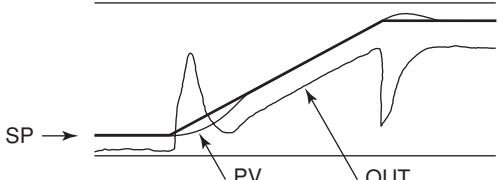
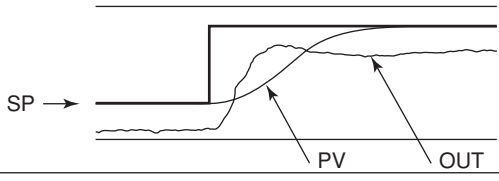
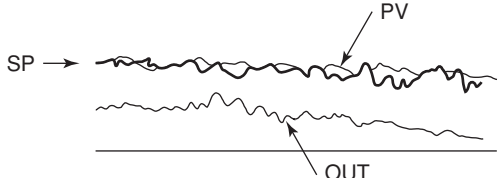
Type of PID Control Mode	Control Method	Description of the Control Operation
Standard PID control mode (Initial value)	PV derivative type PID During operation in local mode or auto mode (only the primary side during cascade control) <u>With bumps in the control output at the time the SP is changed</u>	Employs a PV derivative type PID so that the output reaches the new SP quickly after the target setpoint is changed. In PV derivative type PID, the proportional terms (P) that are proportional to the deviation that occurred due to the SP change are output immediately, forcing the process value to quickly reach the new SP. 
	Deviation derivative type PID During operation in remote mode (secondary side during cascade control) <u>With bumps in the control output at the time the SP is changed</u>	By applying the derivative term (D) against the deviation that occurs due to minute changes in the program pattern, the process value quickly tracks the program pattern. 
Fixed-point control mode	PV derivative type PID During operation in local mode or auto mode (only the primary side during cascade control) <u>Without bumps in the control output at the time the SP is changed</u>	Use this function on continuous fixed-point control, if you do not wish to disturb the PV caused by the sensitive reaction of the control output (OUT) at the time the SP is changed. In the case of "PV derivative type PID + no control output bumps," the output value (OUT) does not drastically change at the time the SP is changed. The deviation is gradually eliminated using only the integral term (I) against the deviation that occurs. 
	PV derivative type PID During operation in remote mode (secondary side during cascade control) <u>With bumps in the control output at the time the SP is changed</u>	Use this function on the secondary loop of cascade control. A stable control output is achieved without sensitively reacting to the output of the primary loop. 

Control Output

Select the type of control output from the following. The type can be selected for each loop.

- Time proportional PID relay contact output
- Time proportional PID voltage pulse output
- Current output (continuous PID control output)
- On/off control relay contact output

Time Proportional PID

The result of PID computation is output using a pulse width of an ON/OFF signal that is proportional to the time. The pulse width is calculated using the following equation with the cycle time (control output period, see next section) taken to be 100%.

$$\text{Pulse width} = \text{Control output (\%)} \times \text{cycle time}$$

You can select relay output or voltage pulse for the output type.

Current Output (Continuous PID Control Output)

The result of PID computation is output using a current (analog signal) that is proportional to the computed PID value. There are four types of output current.

On/Off Control Relay Contact Output

The on and off signals are output using a relay according to the polarity of the deviation between the SP and PV.

Cycle Time

Set the cycle time (control output cycle) for the time proportional PID in the range of 1 s to 1000 s. Setting a short cycle time enables precise control. However, the life of the output relay and the input contact on the control element may be shortened, because the number of ON/OFF operations increases. In general, the cycle time is set around 10 s to 30 s for relay output. You can select the cycle time for each loop.

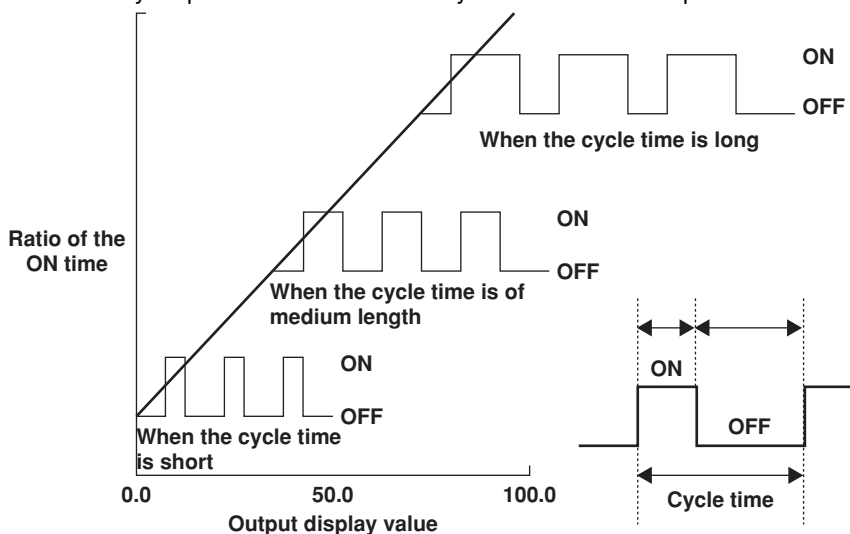

Selecting the Analog Output

Select the type of output current when current output is used from the following: 4-20 mA, 0-20 mA, 20-4 mA, and 20-0 mA.

1.4 PV Input Related Settings

Input Range

Input Type

Select the input source for making input range related settings from the following. Select “RemoteSP” when setting the remote input when you are performing remote/local switching of the SP. When using program control, “RemoteSP” cannot be selected because remote input is not possible.

- During single-loop control or cascade control: PV1/RemoteSP
- During loop control with PV switching: PV1/PV2/RemoteSP/PVrange
Set “process value 1” (PV1) and “process value 2” (PV2). “PVrange” is used for “loop control with PV switching” when the input range of two PV inputs (PV1 and PV2) is different and PV range conversion (see *page 1-24*) is to be performed. When set to “PV range,” “PV upper-/lower-limits,” “unit,” and “PV switching lower/upper limits” (“PV lower-limit” if the input switching method is “PV High”) are set in place of the following settings.

Measurement Mode

Select from the following according to the type of input.

TC (thermocouple), RTD (resistance temperature detector), scale (linear scale), and 1-5 V. Select scale when scaling the input signal to values with an appropriate unit for the application. If you select scale, set the lower and upper limits.

Type (setting only when measurement mode is set to “scale”)

Select the type of input signal from “Volt,” “TC” (thermocouple), and “RTD” (resistance temperature detector.)

Range

Set the range (thermocouple or resistance temperature detector type) that matches the input signal type. This setting determines the measurement range (measurable range).

- Thermocouple
R, S, B, K, E, J, T, N, W, L, U, PLATINEL, PR40-20, and W3Re/W25Re.
- Resistance temperature detector
Jpt100 and Pt100.
- Voltage
Standard signal: 1-5 V (when “measurement mode” is set to “1-5 V”)
Current voltage: 20 mV, 60 mV, 200 mV, 2 V, 6 V, 20 V, and 50 V.

Span

Set the “measurement span,” the actual range of control (upper limit and low limit), within the minimum and maximum values of the measurement range.

Unit

You can enter the unit using up to 6 alphanumeric characters.

PV Correction

Input Filter

The input filter can be used to eliminate noise when harmonic noise is included in the PV input such as in current signals and pressure signals. The input filter is first-order-lag computation. The larger the time constant (parameter setting), the stronger the noise elimination function becomes. The input filter is also used for the improvement of the controllability and for phase correction. The time constant of the input filter can be changed during operation as an operation parameter. Selectable range: OFF (no filter) or 1 to 120 s (initial value is OFF)

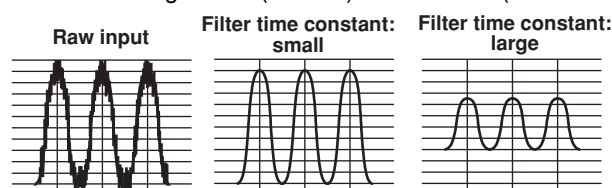

Bias

This function is used to add a constant value (bias value) to the PV and use the result in the display of the PV and control.

$$\boxed{\text{PV input value}} + \boxed{\text{Bias value}} = \boxed{\text{Process value in the instrument}}$$

This function can be used in a case when the PV is less than the true value by a constant amount due to the physical circumstances of the detector. For example, the atmospheric temperature inside a furnace can be measured and substituted for the material temperature. This function can also be used to make minute adjustments when the displayed value is within the allowable precision range but small deviation exists between other instruments and you wish to align it.

Selectable range: -100.0% to 100.0% of the measurement span (the initial value is 0.0%)

Ten-segment Linearizer Biasing Function

This function is used when you wish to correct the input value due to the deterioration of the sensor. In the ten-segment linearizer biasing function, the output value (b) is the corrected value obtained by adding the bias at numerous arbitrary points (up to 11 points can be specified) against the input value (a), as shown in the figure below. For definitions of the engineering units (EU and EUS), see *appendix 8, "Explanation of Engineering Units (EU and EUS)."*

Selectable range of input values: EU (-5.0% to 105.0%) of the measurement span (the initial value is 0.0%)

Selectable range of output values: EUS (-100.0% to 100.0%) of the measurement span (the initial value is 0.0%)

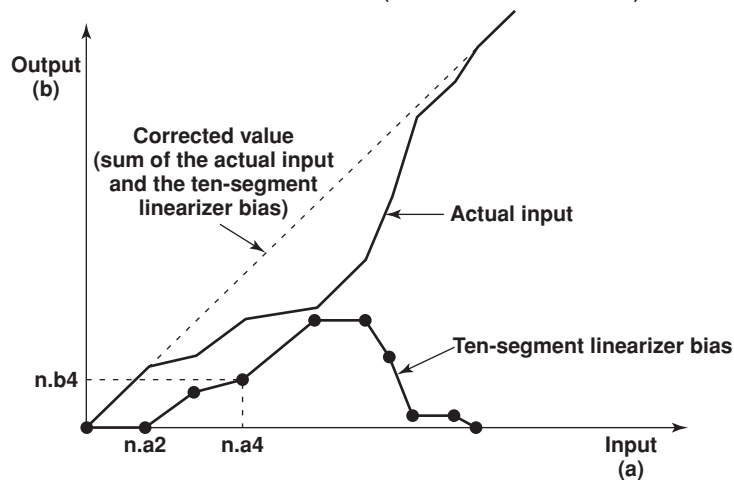
**Ten-segment Linearizer Approximation**

This function is used when the relationship between the input signal value and the value you wish to measure is not linear such as the level meter and the volume of a spherical tank. In the ten-segment linearizer approximation function, you can set the output value (b) to an arbitrary value with respect to the input value (a) of an arbitrary point (up to 11 points can be specified), as shown in the figure below. For definitions of the engineering units (EU and EUS), see *appendix 8, "Explanation of Engineering Units (EU and EUS)."*

Selectable range of input value: EU (-5.0% to 105.0%) of the measurement span (the initial value is 0.0%)

Selectable range of output values: EU (-5.0% to 105.0%) of the measurement span (the initial value is 0.0%)

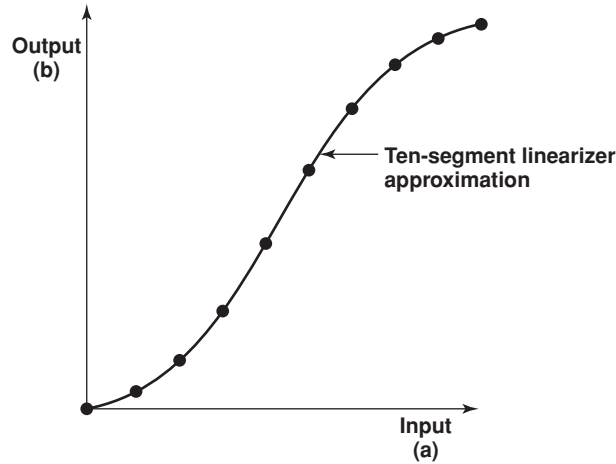

Square-root Computation of PVs

The square-root function is used in the case such as when the differential pressure signal of a restriction flowmeter such as an orifice or a nozzle is converted to a flow signal. You can also set the low-signal cutoff point for the square-root computation. Square-root computation ON/OFF setting: ON or OFF (the initial value is 1.0%) Selectable range of the low-signal cutoff of the analog input: 0.0 to 5.0% (the initial value is OFF)

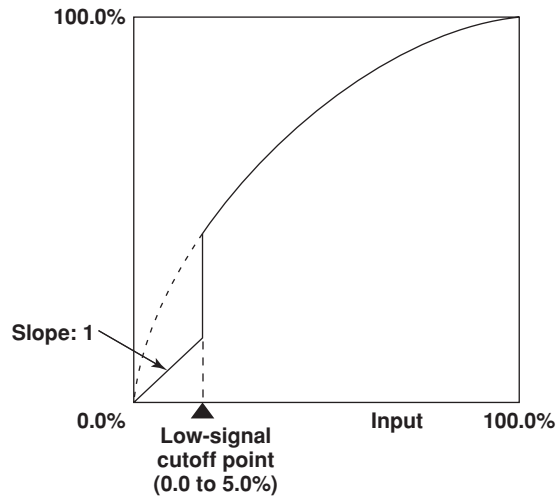

PV Range Conversion (only during loop control with PV switching)

The PV range conversion is a function used to determine the PV range of the control function when the measurement range of the two input signal is different for the loop control with PV switching. For example, if the input range of the first input is 0 °C to 500 °C and the input range of the second input is 300 °C to 1000 °C, the PV range conversion is used to convert the PV range of the control function to 0 °C to 1000 °C.

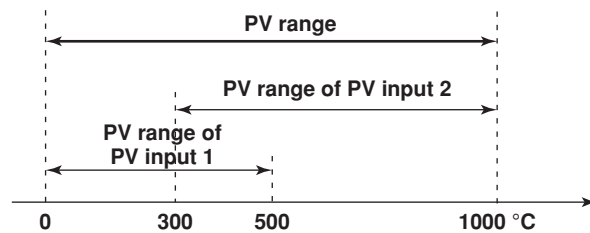

PV Tracking ON/OFF

The PV tracking function is used to prevent radical changes in the PV.

When the PV tracking function is enabled (ON), the SP is forced to match the PV once in the following cases.

- When powering up.
- When switching from manual (MAN) operation mode to auto (AUTO) operation mode.
- When switching from operation stop to operation run.
- When switching the SP number.

The SP is matched against the PV once, and then returns to the original SP according to the “target setpoint ramp-rate (rate of change)” that is specified separately. When using the PV tracking function, make sure to set the SP ramp-rate (rate of change). The ramp-rate is 0 when it is OFF. Consequently, the PV tracking function does not operate in this case. PV tracking function ON/OFF setting: ON or OFF (the initial value is OFF)

- **When PV tracking is OFF**

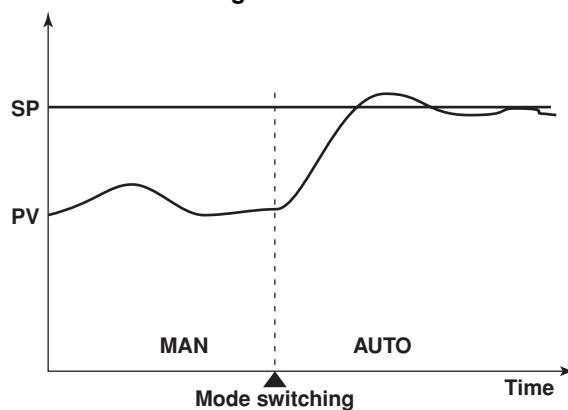

- **When PV tracking is ON**

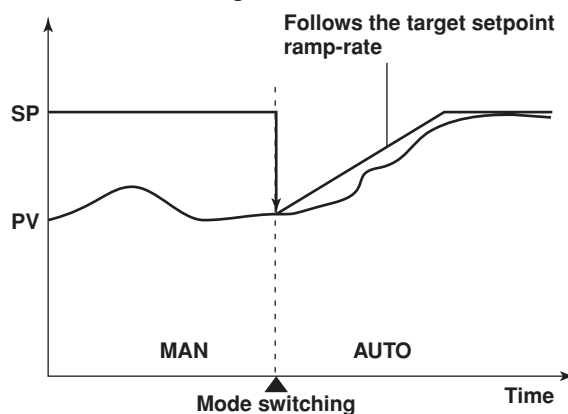

Burnout

When the PV input is a thermocouple or standard signal, a burnout action can be specified. When a burnout is detected, the PV is fixed to positive overrange (when the burnout detection action is set to “UP”) or negative overrange (when the burnout detection action is set to “DOWN”), and the control output is set to preset output.

Reference Junction Compensation

You can select whether to use the internal reference junction compensation function of the CX2000 or an external reference junction compensation function. When using an external reference junction compensation, set an appropriate reference junction compensation voltage. For example, if the reference junction temperature of the external reference compensation is T_0 °C, set the reference compensation junction voltage to the thermoelectromotive force of the 0-°C reference of T_0 °C.

1.5 Contact Input/Output Related Settings

Contact Input/Output Terminal

The contact signal is input or output from the control output terminal block or the control DIO expansion terminal block indicated in the following figure.

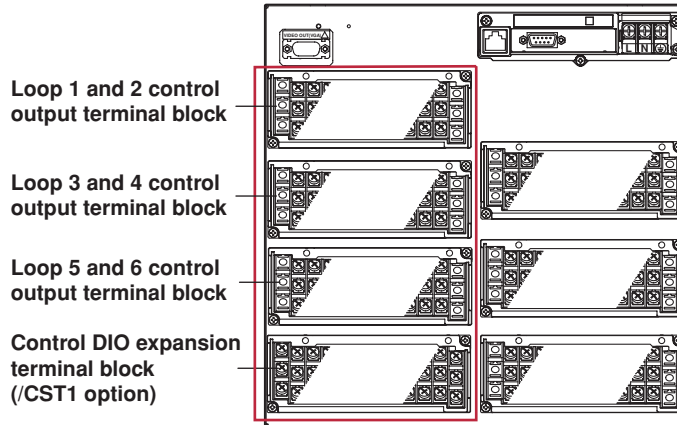

As shown in the following figure, contact input terminals (DIGITAL IN) and contact output terminals (DIGITAL OUT) are arranged on each terminal block. There are two types of contact outputs: relay output and transistor output. For the connection procedure of the signal wires, see *section 2.3, "Wiring"*.

- Loop 1 and 2 control output terminal block

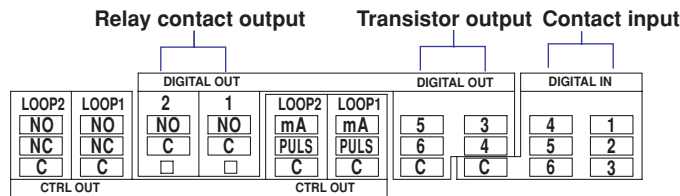

- Control DIO expansion terminal block

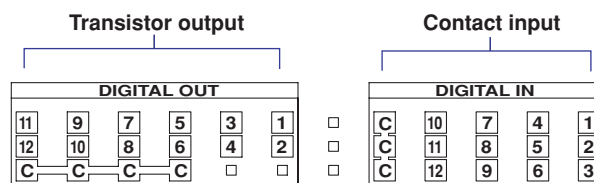

Contact Input

Prescribed operation such as stop/run operation can be performed using contact inputs.

Selecting Terminal Blocks and Terminals

The control output terminal block allows 6 contact inputs; the control DIO expansion terminal block allows 12 contact inputs. Select the terminal block for registering the contact input information by specifying "CTRL1-2," "CTRL3-4," "CTRL5-6," and "EXTDIO" for the loop 1 and 2 control output terminal block, the loop 3 and 4 control output terminal block, the loop 5 and 6 control output terminal block, and control DIO expansion terminal block, respectively. The following contact input numbers are used to select the contact inputs on each terminal block.

Contact input of the loop 1 and 2 control output terminal block: DI001 to DI006

Contact input of loop 3 and 4 control output terminal block: DI101 to DI106

Contact input of loop 5 and 6 control output terminal block: DI201 to DI206

Contact input of the control DIO expansion terminal block: RI001 to RI012

Contact Input Information Registration

You can select the information that is registered to the contact input from the following.

Name of Action	Detection	Action
Stop all loop control operation	Trigger	Stops the operation of all internal loops.
Start all loop control operation	Trigger	Starts the operation of all internal loops.
Stop/run control (loops 1 to 6)	Edge	Starts/stops the operation of each internal loop.
Remote/local (loops 1 to 6)	Edge	Switches the local/remote operation modes of each internal loop.
Auto/Man operation (loops 1 to 6)	Edge	Switches the auto/manual operation modes of each internal loop.
Cascade switching (loops 1-2, 3-4)	Trigger	Switches the internal loops 1-2 and internal loops 3-4 to cascade operation.
Auto operation (loops 1-2, 3-4)	Trigger	Switches the internal loops 1-2 and internal loops 3-4 to auto operation.
Manual operation (loops 1-2, 3-4)	Trigger	Switches the internal loops 1-2 and internal loops 3-4 to manual operation.
Set target setpoint bits 0 to 3	Trigger	Switches the SP to the specified binary value.
Start program operation	Trigger	Starts the program operation (only on models with the program control option).
Reset program operation	Trigger	Resets the program operation (only on models with the program control option).
Hold	Trigger	Holds the program operation (only on models with the program control option).
Advance	Trigger	Advances the program operation (only on models with the program control option).
Set pattern number 0 to 4 bits	Trigger	Switches the program pattern number to the specified binary or binary-coded decimal value (only models with the program control option).
Input switch contact (loops 1 to 4)	Edge	Switches the PV input (PV1, PV2) of each internal loop during loop control with PV input switching.
Start/Stop	Edge	Starts/stops data acquisition to the internal memory.
Trigger	Trigger	Trigger used to start acquiring event data to the internal memory (valid only when "event data" is specified to be acquired to the internal memory and the trigger used to start the acquisition is set to "external trigger").
Alarm ACK	Trigger	Clears alarm display/relay output (valid only when the alarm indicator or output relay behavior is set to "hold").
Time adj	Trigger	Adjusts the internal clock to the nearest hour.
Math	Edge	Starts/stops computation (only on models with the computation function (/M1)).
Math reset	Trigger	Resets computed data of measurement channels (Resets the computed value to 0. Only when computation is stopped on models with the computation function option).
Manual sample	Trigger	Acquires instantaneous values of all channels to the internal memory.
Load setup data 1 to 3	Trigger	Loads the setup data file saved to the external storage medium.
Messages 1 to 8	Trigger	Displays message 1 to 8 on the trend display and stores the message to the internal memory.
Snapshot	Trigger	Saves the screen image data to the external storage medium.

Method of Detecting Contact Inputs

The above operations are carried out on the rising or falling edge of the contact signal (edge) or the ON signal lasting at least 250 ms (trigger). The remote signal rises when the contact switches from "open to closed" and falls when the contact switches from "closed to open." For open collector signals, the remote signal rises when the collector signal (voltage level of the input terminal) goes from "high to low" and falls when the collector signal goes "low to high."

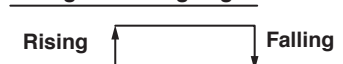
Rising and falling edges**Trigger**

Note

- For a description on how to register contact inputs, see “Setup Items” of *section 4.2, “Basic Control Settings > Contact Input Registration/Misc.”*
 - On models with the measurement alarm option terminal block /A6R or /A4FR, the actions from “Start/stop” to “Snapshot” can also be assigned to the measurement remote input. For a description on the assignment of actions to the measurement remote input, see “Measurement Remote Input” on *page 1-103*.
 - If the same action is performed using keys of the CX2000, communications, and contact input, the newest operation/input is valid regardless of the method. This is also true between contact inputs and measurement remote inputs.
 - If a program start trigger activates through contact input during program hold, hold mode is cleared.
-

Contact Output (FAIL Output, Self Diagnosis Output, and Event Output)

Output Terminal Selection

The control output terminal block allows 6 contact inputs; the control DIO expansion terminal block allows 12 contact inputs. The following contact output numbers are used in the settings.

Contact output of loop 1 and 2 control output terminal block: DO001 to DO006

Contact output of loop 3 and 4 control output terminal block: DO101 to DO106

Contact output of loop 5 and 6 control output terminal block: DO201 to DO206

Contact output of the control DIO expansion terminal block: RO001 to RO012

Setting the Relay Action/Hold

Set whether to energize or de-energize the output relay when outputting failure detection found by FAIL or self diagnosis and events. In addition, set whether the relay output is turned OFF when the condition is appropriate for releasing the output, or hold the relay output until an alarm ACK operation is carried out. In the settings, select the behavior from “deenergize/hold,” “deenergize/nonhold,” “energize/hold,” and “energize/non-hold.” In the case of a transistor (open-collector) output, the signal is switched from Off to On during output for an energize setting and from On to Off during output for a de-energize setting. These relay actions are the same as the alarm output relay actions of the measurement function. For details on energize/de-energize and hold/nonhold, see “Energized/De-energized Operation of Alarm Output Relays” and “Hold/Non-hold Operation of Alarm Output Relays” on page 1-66.

FAIL Output

This is the setting for the function that outputs a relay contact signal when a failure is detected in the CX2000 CPU. When FAIL output is turned ON, “DO001” of the loop 1 and 2 control output terminal block is automatically assigned to “de-energized/hon-hold.”

Fault Diagnosis Output

This is the setting for the function that outputs a relay contact signal when an input burnout, A/D converter failure, or reference junction compensation failure occurs. When fault diagnosis output is turned ON, “DO002” of the loop 1 and 2 control output terminal block is automatically assigned to “de-energized/hon-hold.”

Event Output

On models with the program control option, PV events and time events can be assigned to contact outputs. You can select the output terminal for PV events and time events from DO001 to DO006, DO101 to DO106, DO201 to DO206, RO001 to RO012, and SW001 to SW036.

Note

- If [Diagnostics] or [FAIL] using the [Basic Control Settings] > [#4 Relay Related] command sequence is set to ON, the DO001 or DO002 output from the control output terminal block for loops 1 and 2 is set for dedicated FAIL output or Diagnostics output. In this case, control alarms can be assigned to [DO001] or [DO002], but the setting is disabled.
 - You can specify the internal switches (SW01-SW36) as the event output destination (style number S3 or later).
-



Registering the Contents of Contact Output (Style Number S3 or Later)

In the same manner as with contact input, you can register actions for contact output and internal switches. The actions that can be registered are the same as the actions for the contact input, excluding the 0-3 bit target setpoint setting and the 0-4 bit pattern number setting.

DIO Operation Control Function (Style Number S3 or Later)

There are 7 types of DIO available.

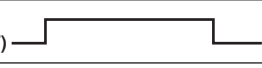
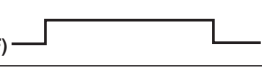
- DI-1: Displays the input status of the specified DI. The status of the internal switches is displayed.
- DO-1: The status of the internal switches is output to 1 DO. 1 (ON) is output when the internal switches are ON, and 0 (OFF) is output when they are OFF.
- DO-2: You can output the ON and OFF statuses of the internal switches to separate DOs. 1 (ON) is output from the ON output DO when the internal switches are ON, and 0 (OFF) is output from the OFF output DO when they are OFF. 0 (OFF) is output from the ON output DO when the internal switches are OFF, and 1 (ON) is output from the OFF output DO when they are ON.
- DIO-11: The same operation as the DO-1 is performed while displaying the input status of the specified DI.
- DIO-12: The same operation as the DO-2 is performed while displaying the input status of the specified DI.
- DO-2P: You can output the ON and OFF statuses of the internal switches to separate DOs. A pulse signal having a 1 to 2 second pulse width is output from the ON output DO when the internal switches are ON, and from the 0 (OFF) output DO when they are OFF.
- DIO-12P: The same operation as the DO-2P is performed while displaying the input status of the specified DI.

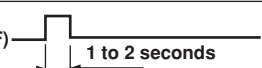
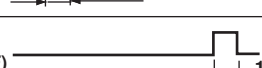
Internal switches		ON OFF 
DO-1/ DIO-11		1 (ON) 0 (OFF) 
DO-2/ DIO-12	DO for ON output	1 (ON) 0 (OFF) 
	DO for OFF output	1(ON) 0 (OFF) 
DO-2P/ DIO-12P	DO for ON output	1 (ON) 0 (OFF) 
	DO for OFF output	1 (ON) 0 (OFF) 

1.6 Target Setpoint Related Settings

Setting the SP

Set the SP, as one of the PID parameters, for each PID number (1 to 8) in the range of EU (0.0 to 100.0% of the measurement span). The PID number in which the SP has been registered is handled as “SP number” when specifying the setpoint and for other purposes.

SP Assignment

The SP is specified using the SP number. The operation at the time of SP number switching varies depending on the PID selection method.

- When target setpoint selection method is selected
The SP number and PID number are synchronized. By switching the SP number, the control parameters (“PID parameters” in the settings) such as the SP and the PID constant are changed to the control parameters registered to the corresponding PID number.

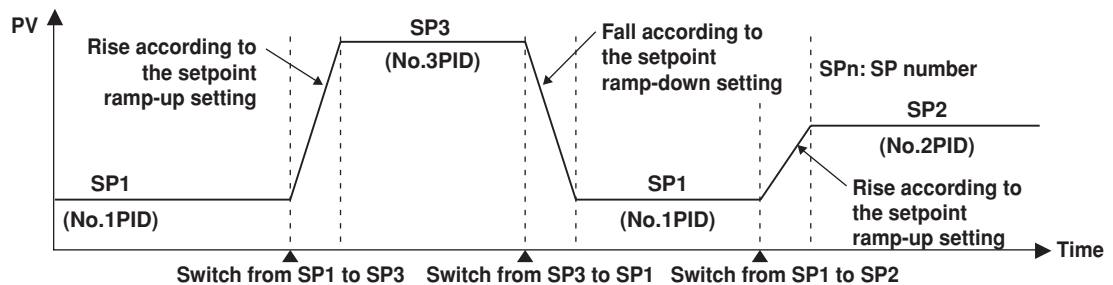

- When zone PID method is selected
The assignment of the SP number and the assignment of the PID number are not synchronized.
A PID number (group number of the PID parameter) is registered for each zone beforehand. When the PV changes and becomes a value of a different zone, the PID number automatically changes, but the SP number does not switch.

Note

The value of control alarms corresponds to the SP number (see section 4.7). If the SP number is changed, the alarm value also changes accordingly.

Selection of the SP Number to Be Switched Using Contact Input

Set loop 1 to 6 for switching the SP number using the contact input “Set target setpoint bits 0 to 3” (see page 1-27).

Target Setpoint Tracking

The CX2000 can perform operation according to the remote SP (remote input) received from an external source. In this case, it is foreseeable that the output value will drastically change when switching from a remote operation condition to a local operation (operation according to the internal SP of the CX2000) condition or switching from program operation to local operation. To prevent the output value from drastically changing, the CX2000 has a function used to track the output from the remote SP to the local SP. The operation image of target setpoint tracking is shown below.

- When target setpoint tracking is enabled

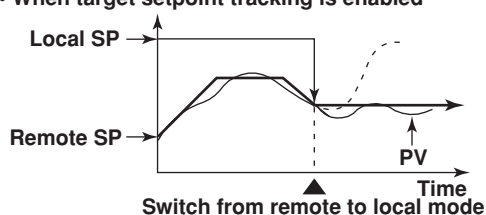

- When target setpoint tracking is disabled

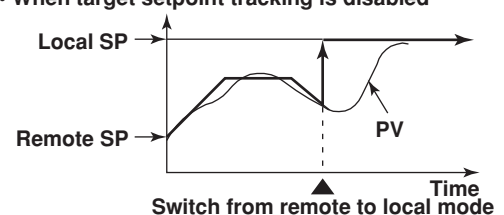

Setpoint Limiter

This function is used to limit the range in which the SP is to change. The value is specified using EU (0.0% to 100.0%). For a definition of the engineering unit (EUS), see *appendix 8, "Explanation of Engineering Units (EU and EUS)."*

When not in program operation: Limit the change in the SP.

When in program operation: Limit the program setpoint.

Ramp-rate Setting during Target Setpoint Switching

When you do not want the SP to change rapidly or when you wish to change the SP at a constant velocity ramp-rate, you can set the velocity ramp-rate (target setpoint ramp-up rate or target setpoint ramp-down rate) for raising or lowering the SP. The specified velocity ramp-rate functions in the following cases.

- When the SP is changed.
- When the SP number is changed.
- When the CX2000 is powered up (or recovers after a power failure).
The SP changes according to the specified ramp-rate from the PV to the SP.
- When the CX2000 is switched from manual operation to auto operation.
The SP changes according to the specified ramp-rate from the PV to the SP.

• When the SP is changed

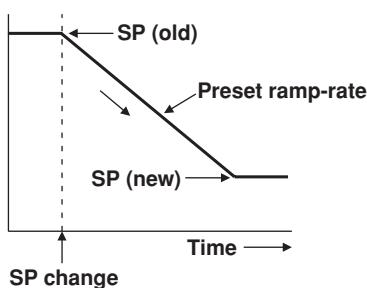

• When the SP number is changed

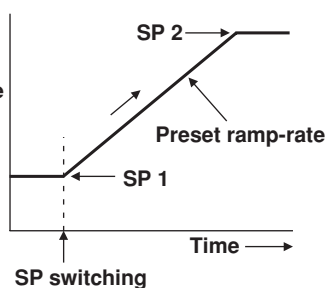

• At the time of power-up (or recovery after power failure) or when manual/auto operation is switched

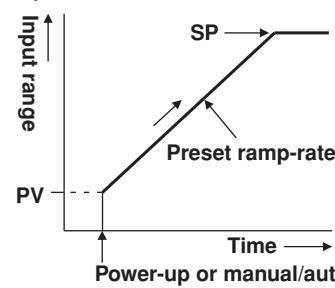

The following figure shows an example in which the ramp-up rate is set to 70 (°C/minute) and the CX2000 is operating at SP 1 = 500 °C and a switch is made to SP 2 = 640 °C.

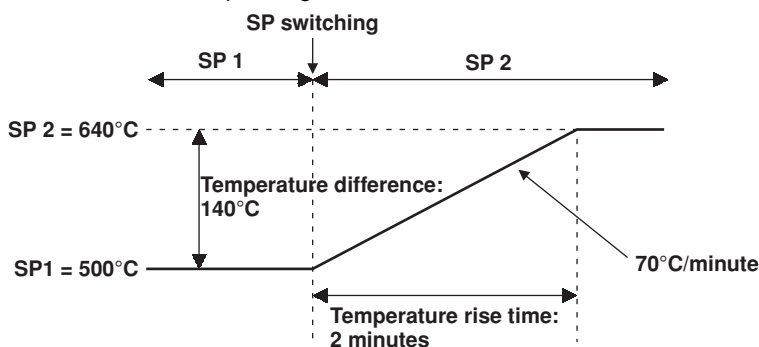

RSP Input

In addition to the value specified on the CX2000, the value determined from the analog signal that is input to the RSP terminal of the control input terminal block can be used as the SP. The input setting for the remote input analog signal is carried out in the same fashion as the input setting for the PV input (see *section 1.4, "PV Input Related Settings"*). When using the SP of the remote input, select [REMOTE] through the local/remote switching operation (see *page 6-4*) on the operation display. The switching operation can also be carried out using the contact input (see *section 1.5, "Contact Input/Output Related Settings"*).

Note

The remote input function can be used only when program control is not used. To use this function, the program control ON/OFF setting (setting available only on models with the program control option) must be set to [OFF] and "[Basic Control Settings] > [Contact Input Registration] > [Remote Input Selection]" must be set to [REMOTE].

1.7 PID Parameter Settings

PID Number

PID parameter group number. The PID number can be set for each loop. When the PID group number setting is "8", you can select the PID number from 1 through 8. However, if the PID group number is set to a smaller number, the maximum selectable PID number is decreased accordingly.

Note

- The parameters that are registered to a single PID number include the PID constant, output lower/upper limit, control action method, preset output value, shutdown function ON/OFF, and manual reset value.
- In the zone PID method, a single PID number is assigned to each zone (zone specified by reference points 5 and 6 is assigned a PID number of 6, for example). When the zone changes, the parameter switches to the control parameters assigned to the PID number, and the output is controlled accordingly.

PID Number Assignment

The PID number assignment operation varies depending on the PID selection method.

- When using the target setpoint selection method
The SP number and PID number are synchronized. By switching the SP number, the control parameters ("PID parameters" in the settings) such as the SP and the PID constant are changed to the control parameters registered to the corresponding PID number.
- When using the zone PID method
PID numbers are assigned to each zone beforehand. When the PV changes and becomes a value of a different zone, the output is controlled automatically using the PID parameters of the PID number that is assigned to that zone. The following settings are required when using this method.

Reference Points

As shown in the following figure, reference points 1 to 6 (up to 7 zones) are specified to divide the measurement span into zones. The number of reference points that can be specified is "PID group number - 2." As shown in the following figure, if the PID group number is 7, the number of reference points is 5. If the number of reference points is 5, there are 6 zones.

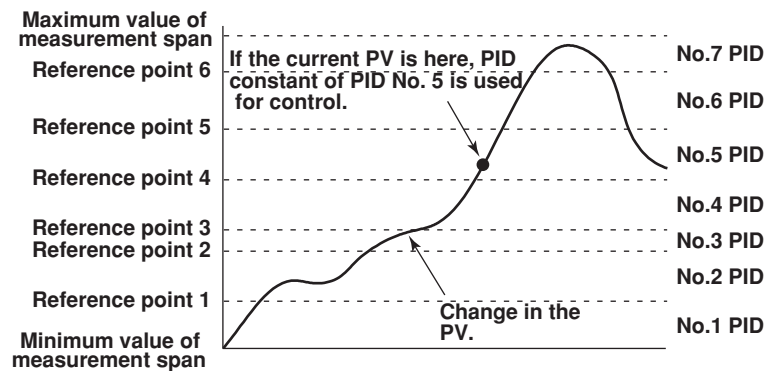

Switching Hysteresis

You can set the hysteresis used in the zone switching in EUS (0.0% to 10.0%) of the measurement span. The hysteresis is initially set to 0.5% of the measurement span.

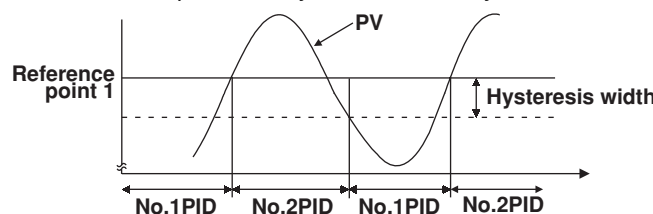

Reference Deviation

During control operation, the operation can be switched automatically to a preset PID constant (PID constant with the largest PID number. For example, if the PID group number is 8, the PID constant of PID number 8.) when the deviation between the SP and the PV exceeds the “reference deviation” setting. For example, when the deviation is large, you can increase the proportional gain (decrease the proportional band) to make the output reach the SP quickly. The switching of the PID constant by the reference deviation has precedence over the switching of the PID constant by the zone PID. When the actual deviation becomes smaller than the “reference deviation” setting, the CX2000 returns to the operation using the PID constant assigned to the zone corresponding to the PV at that point.

The previously described switching hysteresis is also applied to the reference deviation.

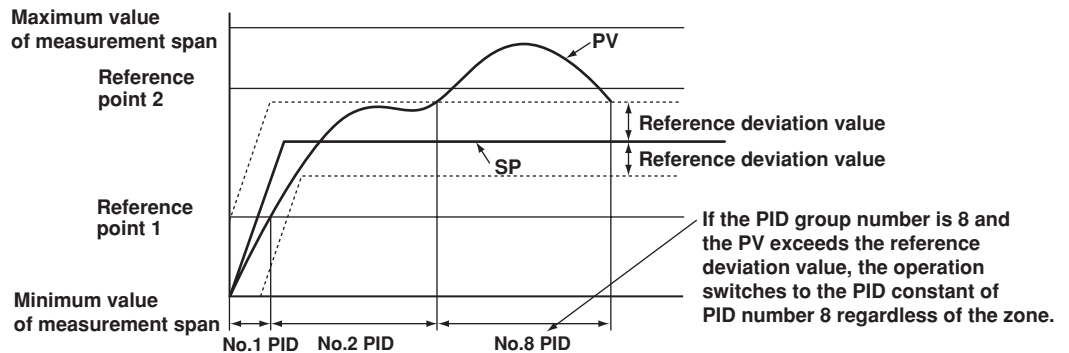

PID Constant

Proportional Band (P)

The proportional band is specified in the range of 0.1 to 999.9% of the measurement span.

Integral Time (I)

The integral time is set in the range of 0 to 6000 s.

Derivative Time (D)

The derivative time is set in the range of 0 to 6000 s.

Control Output Limiter

The control output limiter is a function that allows the upper and lower limits of the operation range of the control output (output limiter) regardless of operation mode. Selectable range of upper/lower limits: -5.0% to 105.0% (where upper limit > lower limit)

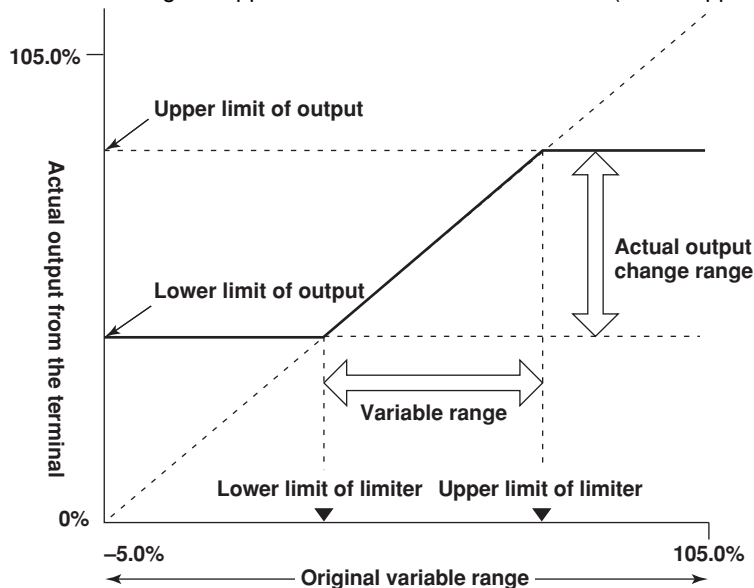

Selectable range: $-5.0\% \leq \text{lower limit of limiter} < \text{Upper limit of limiter} \leq 105.0\%$

Shutdown Function ON/FF (can be specified only during manual mode using 4- to 20-mA current output)

The shutdown function closes the control value fully (set the output to 0) exceeding the dead band of the control valve positioner. When this function is turned ON, the control output is set to 0 mA if the manual control output becomes -5.0%.

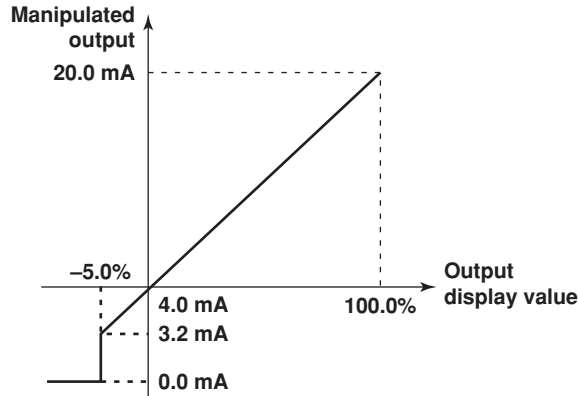

Note

The "output high-limit alarm" is not activated even if the control output becomes 0 mA due to shutdown.

Manual Reset Value (valid only when the integral action is Off)

The manual reset value is the output value when the PV is equal to the SP. For example, if the manual reset value is set to 50%, the output value is set to 50% when PV = SP. Selectable range of manual reset value: -5.0 to 105.0%

Control Direction

The control action direction defines the direction (increase or decrease) in which the control output value changes according to the polarity of the deviation between the SP and the PV. In reverse action (factory default setting), the control output value decreases when the PV is greater than the SP and vice versa. The control output is varied using direct control or reverse control specified beforehand in sync with the deviation between the SP and the PV at that point. Direct action and reverse action can be switched in the middle of operation.

	Reverse action		Direct action	
	PV>SP	PV<SP	PV>SP	PV<SP
ON/OFF output	OFF	ON	ON	OFF
Current output	Current decrease	Current increase	Current increase	Current decrease
PV time-proportional output	ON time decrease	ON time increase	ON time increase	ON time decrease
Output change direction for the 4-20 mA case	<p>The graph shows Output value on the y-axis (4 mA to 20 mA) and PV on the x-axis. A setpoint SP is marked with a downward arrow. A downward-sloping line represents the output response. When PV is greater than SP, the output decreases from 20 mA towards 4 mA. When PV is less than SP, the output increases from 4 mA towards 20 mA. Labels include 'Minimum value (PV is low)' and 'Maximum value (PV is high)'.</p>		<p>The graph shows Output value on the y-axis (4 mA to 20 mA) and PV on the x-axis. A setpoint SP is marked with a downward arrow. An upward-sloping line represents the output response. When PV is greater than SP, the output increases from 4 mA towards 20 mA. When PV is less than SP, the output decreases from 20 mA towards 4 mA. Labels include 'Minimum value (PV is low)' and 'Maximum value (PV is high)'.</p>	

Preset Output

The preset output function outputs a constant value (preset output value) independently from the control output value present up to that point when the following conditions occur.

- When an input burnout occurs during operation in auto mode or cascade mode.
- When a failure occurs in the A/D converter during operation in auto mode or cascade mode.
- When the operation of the CX2000 is switched from run to stop.

The initial preset output value is set to 0.0%. However, the preset output value can be set to a value in the range of –5.0 to 105.0% regardless of the high and low limits of the output limiter.

Note

If you are setting (changing) the preset output value, presume the case when the preset output is actually used, check the appropriate output value, and set the value. After confirmation, change the preset output only when it is necessary.

1.8 Control Output Suppression Settings

Anti-Reset Windup (Over-Integration Prevention)

There are certain cases in which a large deviation between the SP and PV is present for an extended time such as when control operation is started. In such cases, the control output may reach the high limit of the output limiter and become saturated due to the integral action. In the end, an overshoot may occur. To prevent this from happening, the anti-reset windup function is used to pause the integral action when the manipulated output reaches the high limit of the output limiter.

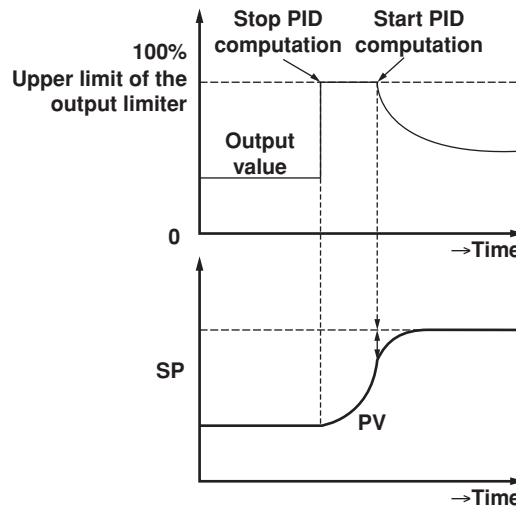

The function can be set automatically or manually. When manually setting the function, the point at which the integral computation is resumed is set in terms of a deviation width (%). The deviation width is derived using the following equation.

$$\text{Deviation width (\%)} = \frac{IPV - SPI}{\text{proportional band}} \times 100$$

Selectable range of deviation width: 50.0 to 200.0%

Control Output Suppression

You can use the overshoot suppressing function that uses fuzzy logic. The overshoot suppression function works only during PID control when all PID constants are specified. When the overshoot suppression function is used, the deviation is monitored to detect the danger of overshooting. If danger is detected, the SP is automatically changed to a slightly lower tentative value referred to as the "auxiliary SP", and the control continues. Then, when the PV enters a range in which overshooting is no longer a danger, the auxiliary SP is gradually returned to the original SP.

The following cases are examples in which this function is effective.

- When you wish to suppress overshooting.
- When you wish to shorten the rise time.
- When load fluctuation is frequent
- When the setpoint is changed frequently.

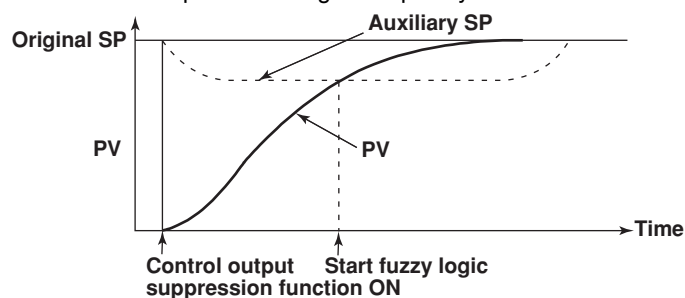

Output Velocity Limiter

This function is used to prevent radical changes in the control output to protect the control element and object of control. Since this function negates the derivative action, use caution when using this function on derivative type control.

Selectable range of velocity: 0.1 or 100.0%/s

1.9 Settings for ON/OFF Control

Target Setpoint

The target setpoint (SP) is set on the PID Parameter setting display (see *page 4-25*) in EU (0.0 to 100.0% of the measurement span) in the same fashion as the PID control. On the PID parameter setting display, you select a PID number in the range of 1 to 8 and register one SP for each PID parameter as with other parameters. However, in ON/OFF control, the PID number functions as a SP number.

Relay Hysteresis

In ON/OFF control output, you can set hysteresis to prevent chattering. The hysteresis is set using the setpoint (0.0 to 100.0%) and the hysteresis activation position (center, low limit, and high limit).

When the activation position setting is "Center"

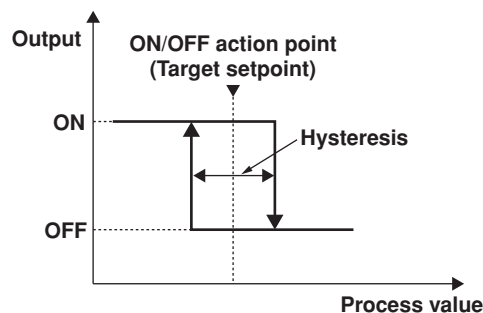

Settings of Other Control Parameters

The following control parameters are common with PID control.

- Control action direction
- Preset output
- Control alarm mode
- SP tracking
- PV tracking
- Setpoint limiter
- Target setpoint ramp-rate setting

Switching Control Parameters by PV Zones

When Zone PID is turned ON, the following control parameters can be switched according to the specified PV zones. Like in the case with PID control, reference points 1 to 6 (up to 7 zones) for setting the zones correspond to the SP number (1 to 7, PID number on the setting display).

- Relay hysteresis
- Control action direction
- Preset output

Control Mode Selection

ON/OFF control output also allows single-loop control, cascade control, and loop control with PV switching. However, for cascade control, the secondary output is ON/OFF control output, but the primary output is the computed result obtained by the PID constant that is assigned to the primary loop. Therefore, a PID constant is assigned to the parameter of the PID number assigned to the primary loop.

1.10 Control Alarm Related Settings

Alarm Operating Conditions (Alarm Mode)

The following three types of alarm operating conditions are available for selection.

- Alarm is always enabled ← initial value
- Alarm is disabled when operation is stopped.
- Alarm is disabled when operation is stopped or during manual (MAN) operation mode.

Alarm Type

You can select the alarm type from the following.

Alarm type	Alarm action (Open/close: relay contact status)	Alarm type	Alarm action (Open/close: relay contact status)
PV high-limit		Deviation within high & low limits	
PV low-limit		SP high-limit	
Deviation high-limit		SP low-limit	
Deviation low-limit		Output high-limit	
Deviation high & low limit		Output low-limit	

Action When an Alarm Occurs

Alarms can be generated at the contact output and on the CX2000 display.

The alarm contact output can be assigned to the [DIGITAL OUT] terminal (see *page 2-6*) of the control output terminal block and the control DIO expansion terminal block.

The alarm display can be confirmed by the mark on the control group displays, alarm occurrence history on the alarm summary display, and the alarm icon on the operation status display section.

Note

- The CX2000 has measurement alarms (see section 1.15, "Measurement Function > Measurement Alarm Related Settings") in addition to the control alarms. The measurement alarms can also be output at the contact output and on the display. Measurement alarms can be output from the [DIGITAL OUT] terminal of the control output terminal block and the control DIO expansion terminal block and the [ALARM] terminal of the measurement alarm option terminal block. In terms of displays, the measurement alarms are displayed along with control alarms on the alarm summary display. The alarm icon on the operation status display section is shared with control alarms (indicator hold behavior is also common).
- You cannot assign the control alarm output to the [ALARM] terminal of the measurement alarm option terminal block.

Setting the Alarm Value

An alarm is registered for each SP of a single control loop. If the SP number (1 to 8) is switched, the alarm value switches accordingly. Since up to 4 alarm types can be assigned for each control loop, four alarm values can be assigned per SP number. You can set the alarm value in the following range.

PV high/low limits, SP high/low limits: EU (0 to 100%) of the measurement span.

Deviation high/low limits: EUS (-100 to 100%) of the measurement span.

Deviation high & low limit, deviation within high & low limits: EUS (0 to 100%) of the measurement span

Output high/low limit: -5.0 to 105.0%

Note

The alarm number corresponds to the SP number. If you change the SP number, the alarm switches to the value of the corresponding alarm number.

Alarm Stand-by Action

When the PV input reaches the SP at the initial stages of control operation, you can put the alarm output on standby.

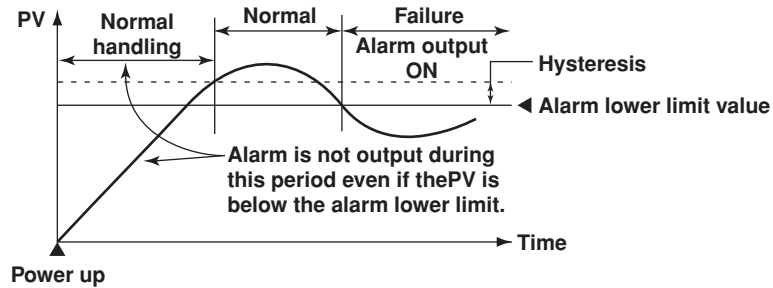

Alarm Hysteresis

The alarm hysteresis can be set in the range of EUS (0.0% to 10.0%) of the measurement span. Below is an example of setting the hysteresis of alarm 1 when the alarm 1 type is set to PV high limit. Open and close in the figure indicate the relay contact status. If the alarm switching (ON/OFF) is excessive, the alarm hysteresis can be widened to lessen the excessiveness. In the right figure, the switching of the alarm (ON/OFF) is slow because the hysteresis width has been widened.

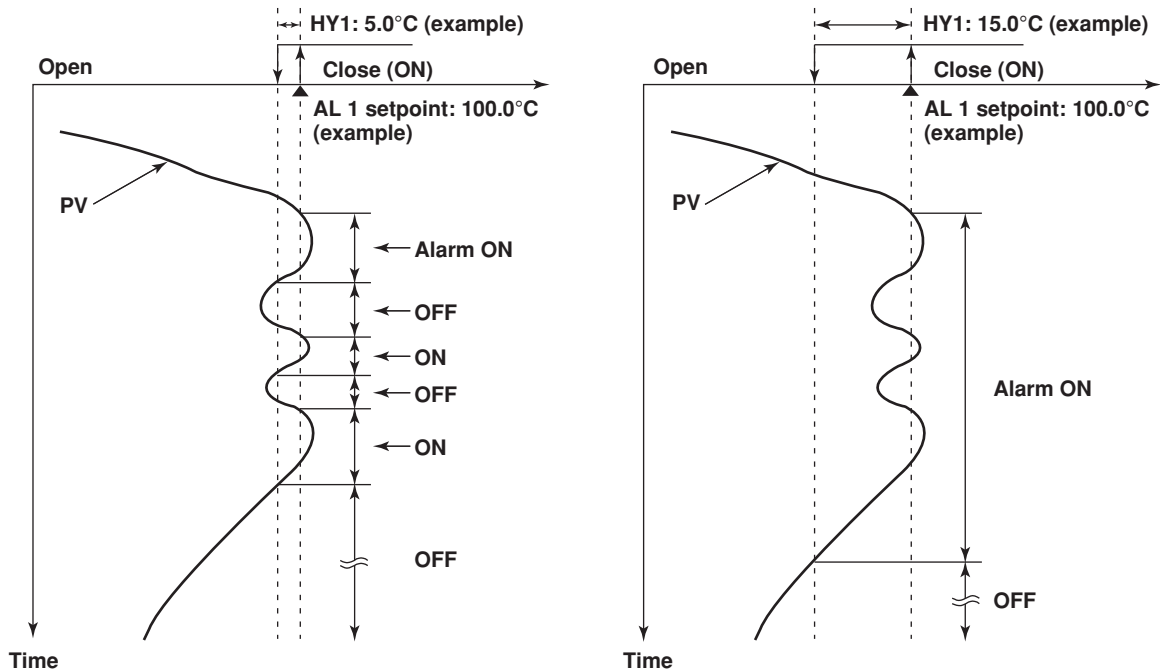

1.11 Program Control Related Settings

Selecting the PID Selection Method

When program control is turned ON, select segment PID method (zone PID selection OFF) or zone PID method.

- **Segment PID method**

Segment PID method is a function in which the PID setpoint is switched for each segment according to the program pattern setting during program operation.

Therefore, this method is suitable for control in which the PID constant is changed during ramp-up and ramp-down in the same PV region.

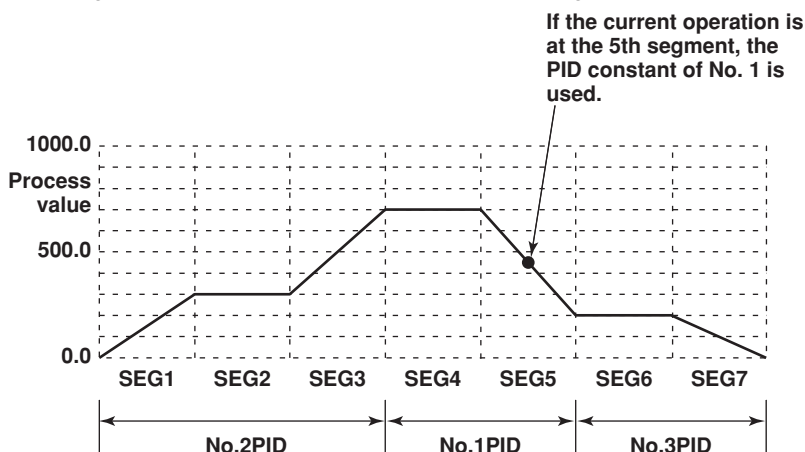

- **Zone PID method**

Zone PID method is a function in which the PID setpoint is automatically switched according to the PV. Therefore, the same PID constant is used in the same PV region regardless of the ramp-up and ramp-down program operation. This method is used on equipment such as reactors in which the chemical reaction gain varies depending on the temperature.

As shown in the following figure, the measurement span can be divided into up to 7 zones using reference points 1 to 6. An optimum PID constant can be assigned to each zone. Therefore, even if the PV changes and crosses between the zones, the output is controlled automatically using the PID constant that is assigned to each zone.

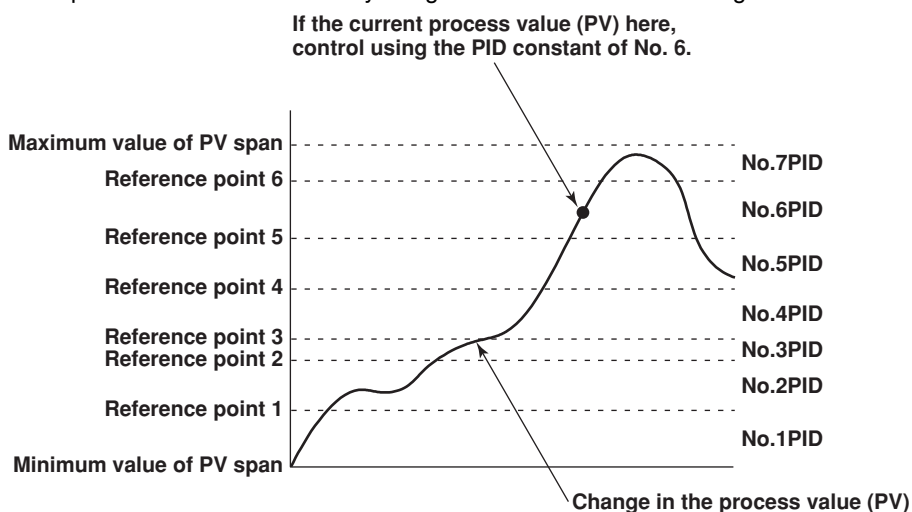

Program Pattern Number and Pattern Name

From the multiple program patterns available, you can switch the program pattern used in the operation by specifying a number according to the conditions. Each program pattern can be assigned a pattern name.

Program pattern number: 1 to 30 (1 to 4 on the /P1 option).

Pattern name: Up to 16 characters.

You cannot change the pattern number during program control. However, if contact input is used to change the pattern number, the changes take effect when program control ends.

With style number S3 or later, you can execute a program pattern while a separate program pattern is executing if the operating loops do not overlap. You cannot change to an executing program pattern and an overlapping pattern number of an operating loop. However, when changing the pattern number by contact input, the changes take effect from the point at which the program stops.

Number of Segments Used

The selectable number of segments is as follows:

- Number of segments that can be assigned to a single program: 1 to 99.
- Total number of segments constructing all program patterns: 300 max.

Segment Assignment Method

The following two types of segment assignment methods are available for selection.

- **Segment time assignment method** (factory default setting)

This method sets the action inside the segment using the final SP (control setpoint at the end of the segment) and the segment time (time length from the start of the segment to the end). Selectable range of final SP: Within the control measurement span (within PV range span during loop control with PV switching).

Selectable range of segment time: 00:00:01 to 99:59:59.

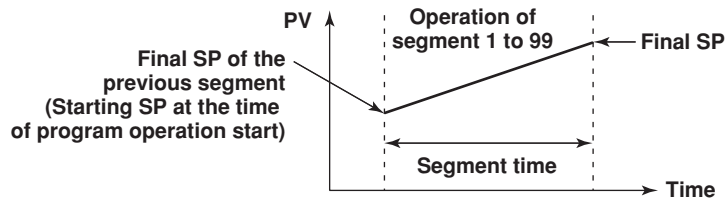

- **Segment time ramp-rate assignment method**

This method sets the action within the segment using the final SP and the ramp-rate value. The ramp-rate value for ramp-up or ramp-down (SP change) is the amount of change in the SP per 1 hour or 1 minute. The ramp-rate is common to all loops of program control. Therefore, make the measurement span the same for all loops of program control as much as possible. If the measurement span is not the same, the ramp-rate is set using the smallest numbered loop of all loops of which program control is ON. Based on this ramp-rate, the ramp-rates of other loops are set proportional to the corresponding measurement spans.

The segment time during ramping is the maximum time in the specified loops. The maximum time is 99:59:59. If this value is exceeded in the calculation, the control moves to the next segment. Selectable range of ramp-rate during ramping is within the control measurement span (within PV range span during loop control with PV switching).

The segment time during soaking (the setpoint is constant) is the time length of the segment.

Selectable range of segment time during soaking is 00:00:01 to 99:59:59.

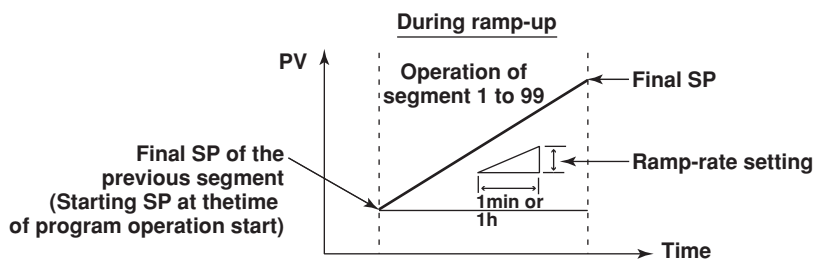

The segment assignment method applies to all segments constructing the program pattern. Note that the contents of all program patterns created before are cleared when the segment assignment method is changed.

Selecting the Start Condition for Program Operation

The following four operation start conditions (start codes) are available for selection.

- Starting SP start (initial value).
- Ramp-prioritized PV1 start
- Time-prioritized PV start
- Ramp-prioritized PV2/3/4/5/6 start

Starting Target Setpoint Start

The starting SP is the SP at the start of the program operation.

When set to starting SP start, the SP is changed from the starting SP to the final SP. In this case, the change follows the ramp-rate defined by “(final SP – starting SP)/segment time” regardless of the PV. When segment time ramp-rate assignment method is selected, the change follows the specified ramp-rate.

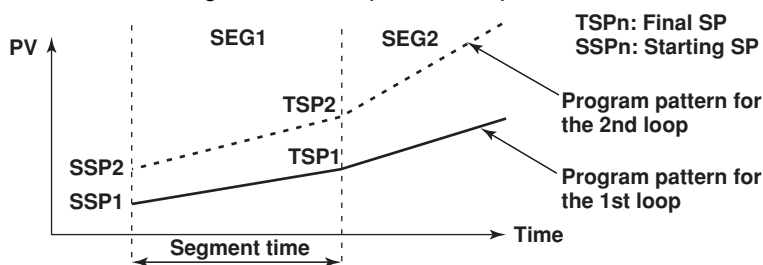

Ramp-prioritized PV Start

In ramp-prioritized PV start, the program operation is started by specifying one of the process values (PV1 to PV6) of loops 1 to 6. The patterns of other unspecified patterns start according to the PV start pattern of the specified loop. The start point varies depending on the comparison between the starting PV of the specified loop and the SP specified by the program pattern. The section of the program pattern that is compared is from the starting SP to the first soak point or the first ramp-down start point (when the start segment is ramp-up). The start point is the point at which the starting PV value and the setpoint on the program pattern match. If this matching point is not found, the start point is the end point of the program pattern being compared against.

If the segment consists of only an up ramp and the starting PV is greater than the final SP, the program control will not start and program control ends. In this case, SP tracking process is not performed. If the start segment is a soak, this function does not operate, and the start condition is the same as with the starting SP start.

Loops set to ramp-prioritized PV start that are in local or stopped mode and are no longer in program operation mode, change to starting SP start.

Below are examples of ramp-prioritized PV1 start and ramp-prioritized PV2 start.

1.11 Program Control Related Settings

- **Example in which the 2nd segment of the 1st loop is a soak segment**

When set to ramp-prioritized PV1 start, the ramp-rate of the 1st loop is prioritized. The program operation start point of the 1st loop will be point C1, D1, or E1 (depends on the PV position a to e at that point). The program operation start point of the 2nd loop (one of the other loops) is at the same time as that of the 1st loop. For example, if the program operation start point of the 1st loop is point C1, the program operation start point of the 2nd loop is point C2.

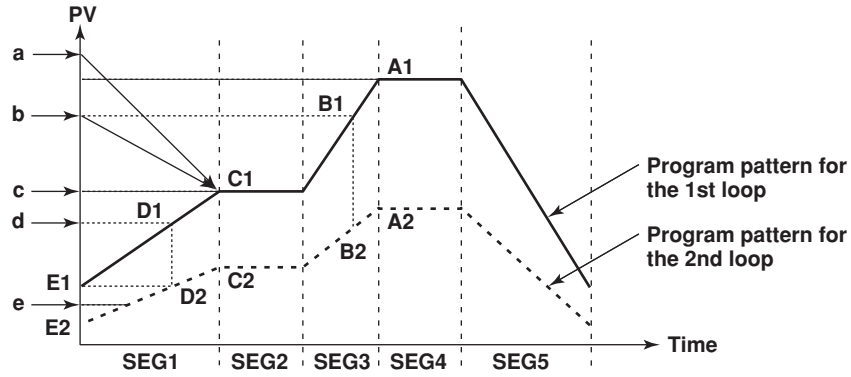

- **Example in which the 3rd segment of the 2nd loop is a soak segment**

When set to ramp-prioritized PV2 start, the ramp-rate of the 2nd loop is prioritized. The program operation start point of the 2nd loop will be one of the points from A2 to E2 (depends on the PV position a to e at that point). The program operation start point of the 1st loop (one of the other loops) is at the same time as that of the 2nd loop. For example, if the program operation start point of the 2nd loop is point A2, the program operation start point of the 1st loop is point A1.

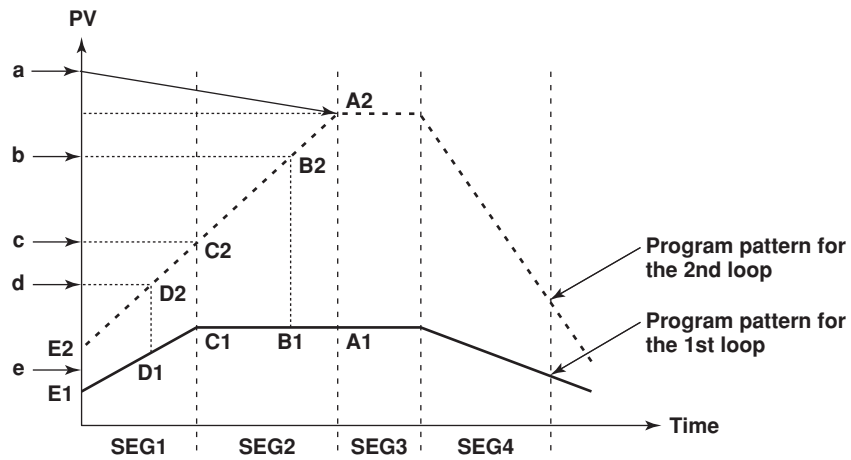

• **Example in which the segment consists of only an up ramp**

When set to ramp-prioritized PV1 start, the ramp-rate of the 1st loop is prioritized. The program operation start point of the 1st loop will be one of the points from B1 to E1 (depends on the PV position a to e at that point. If the PV position is at point a, program operation will not start). The program operation start point of the 2nd loop (one of the other loops) must be at the same time as that of the 1st loop. For example, if the program operation start point of the 1st loop is point B1, the program operation start point of the 2nd loop is point B2.

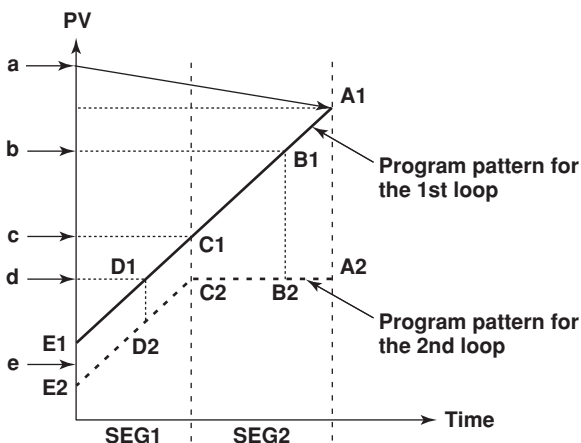

Time-prioritized PV Start

Program operation is started by prioritizing the segment time to change the SP from the PV at the start of program operation to the final SP of the 1st segment. The ten-segment linearizer ramp is defined by “(final SP – PV)/segment time.” When the 1st segment is a soak segment, the start condition is the same as with the starting target setpoint start.

• **Example in which the 2nd segment is a soak segment**

The program operation start point of the 1st loop is always one of the points from point a to e. Since the program operation start point of the 2nd loop is at the same time as that of the 1st loop, the program operation start point is one of the points point a2 to e2.

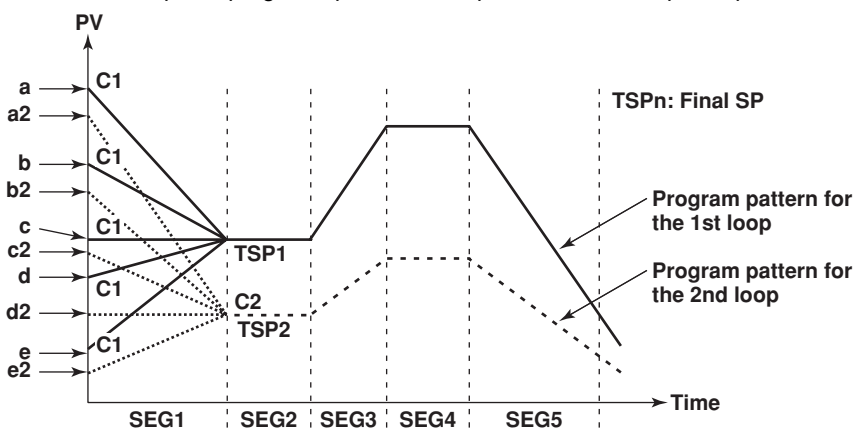

Note

This start method cannot be selected if the segment setting method is set to segment time ramp grade.

Switching Conditions of Program Segments

The operating conditions related to the switching of the segments can be specified for each segment. Such conditions include the condition for switching to the next segment and the operating conditions within the segment. The following four conditions for switching the segment are available.

- Switching for continuation (initial value)
- Hold-on switching
- Local-mode end
- Reset-mode end

Switching for Continuation

When the segment set to switching for continuation ends, the next segment is executed. When switching for continuation is specified on the last segment, the program operation is the same as when reset-end is specified. Below is an example of segment switching for continuation.

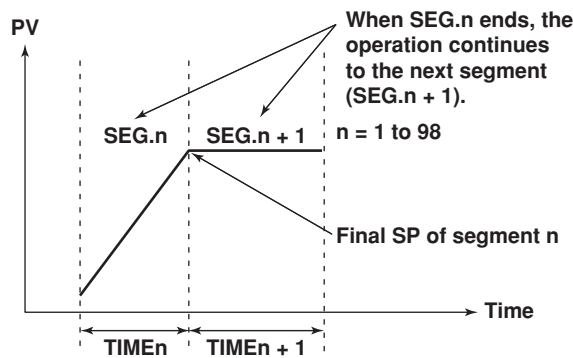

Hold-on Switching

When a segment set to hold-on switching ends, the program operation is paused (hold operation).

The hold condition continues until the hold operation mode is cleared through key operation, external contact, or communication function. If the hold operation mode is cleared at the last segment, the program operation is stopped (reset) and each control loop enters the STOP status. In addition to releasing the hold mode, executing program RUN operation or executing advance during hold operation also clears the hold mode. Below is an example of segment hold-on switching.

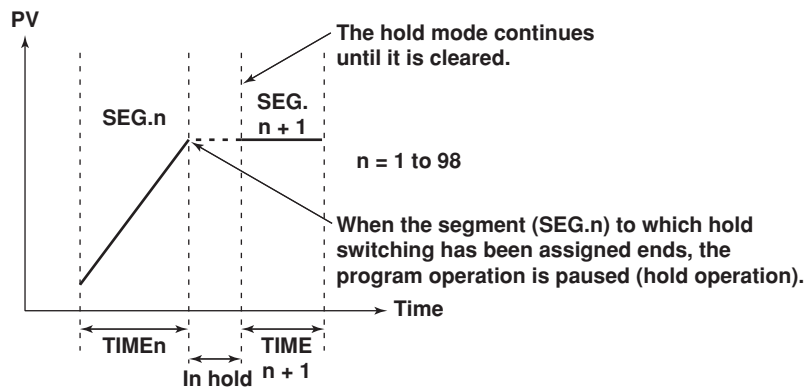

Local-Mode End

When the segment set to local-mode end is terminated, program control enters the stop (reset) status, and each control loop operates in the local mode (constant SP). The SP that is used varies depending on the ON/OFF condition of target setpoint tracking as follows. In addition, when the operation enters local mode, PV event and time event are turned OFF.

• **When the target setpoint tracking is ON**

When the program operation of the last segment ends, the operation is set to local mode (constant SP) as shown below. At this point, the final SP of the last segment is used continuously as the SP in local mode. The "local SP" can be specified beforehand. However, if the target setpoint tracking is ON, the PV tracks to the final SP of the final segment regardless of the local SP.

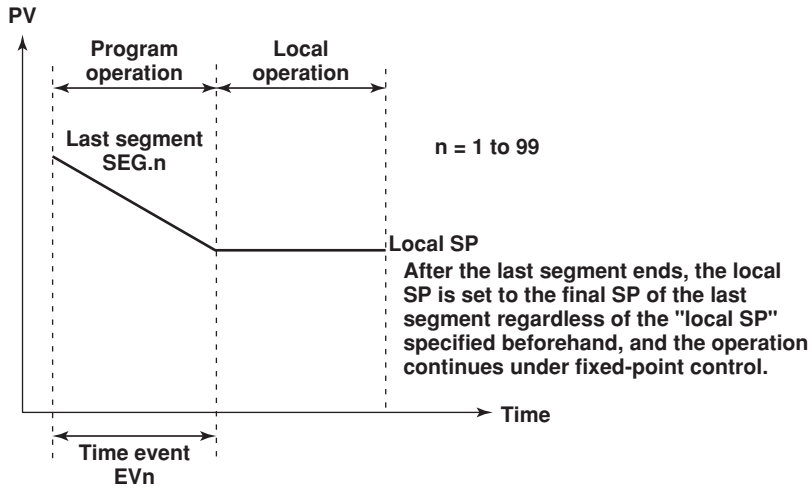

• **When the target setpoint tracking is OFF**

When the program operation of the last segment ends, the operation is set to local mode (constant SP) as shown below (next page). At this point, the output is controlled using the preset "local SP," and PV event and time event are turned OFF.

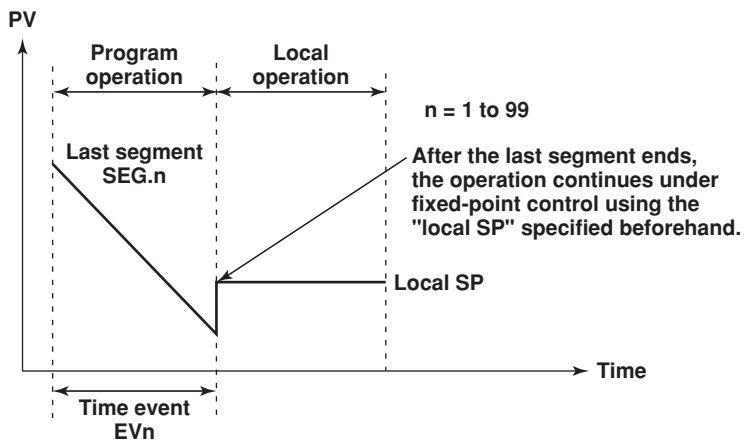

Reset-Mode End

When the segment set to reset-mode end is terminated, program control enters the stop (reset) status, and the operation of each control loop is stopped.

Note

When creating the program pattern, data is created so that the segment set to [Local] or [Reset] is the last segment of program control.

Wait Operation

This function is used to pause the program operation when the PV cannot track the SP. The program is paused to stop the change in the SP and waits for the PV to track the SP. When the PV tracks the SP, the program operation is automatically resumed.

This function has the following two types of operation.

- Wait at the time of segment switching
- Wait within the segment

The operation is set using the wait zone, which is the deviation width used to determine the tracking level of the PV input, and the wait time, which is the time until the wait zone is reached. Up to 5 groups of wait zone and wait time combination can be specified.

The wait operation applies to each loop. Therefore, if the PV of any loop does not reach the wait zone, the operation switches from run mode to wait mode. Wait operation does not apply to loops that are in local mode or that are stopped. In cascade control, if the primary loop is in local mode or if the secondary loop is stopped, wait operation does not apply. If in hold mode, wait operation is not performed because hold mode has precedence.

Wait at the Time of Segment Switching

Wait at the time of segment switching is the wait operation that is performed when the PV has not reached the final SP before changing to the next segment. If the PV reaches the wait zone within the wait time, the operation moves to the next segment at that point. If the PV does not reach the wait zone within the wait time, the operation moves to the next segment after the wait time elapses.

When the operation is switched to hold mode during wait operation, the wait time is reset. If the PV has not reached the wait zone when the hold mode is cleared, the timer is restarted from zero. If the remaining segment time is changed when in hold operation, wait at the time of segment switching no longer applies, and the wait operation is reset.

- **Operation when the PV reaches the wait zone within the wait time**

If the PV reaches the wait zone of the final SP before the wait time elapses after the wait operation is started, the operation switches from wait mode to run mode and transits to the next segment.

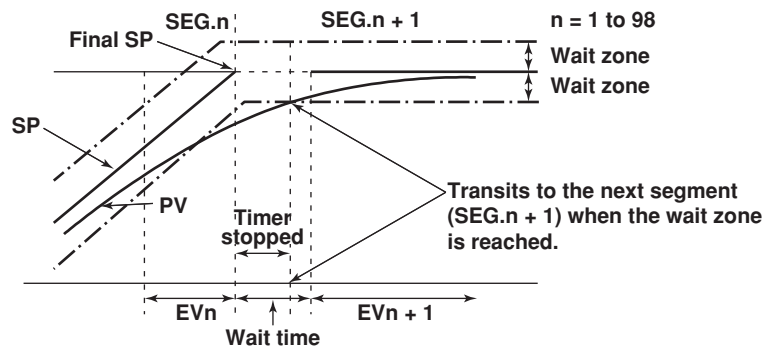

• **Operation when the PV does not reach the wait zone within the wait time**

If the wait time elapses before the PV reaches the wait zone, the operation switches from wait mode to run mode at that point (even if the PV has not reached the final SP) and transits to the next segment. However, if the wait time is set to 00:00:00, the wait operation continues until the PV reaches the wait zone.

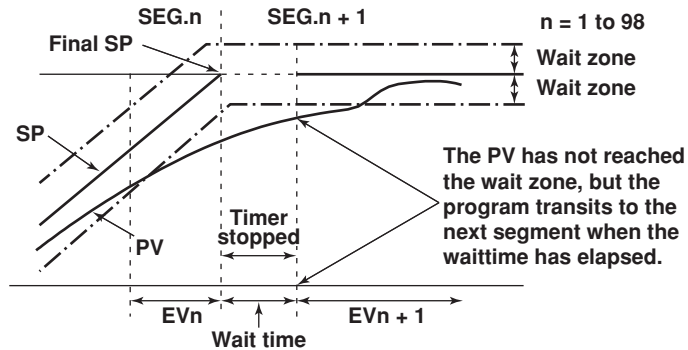

Note

If the wait time is changed during wait operation, wait operation continues using the new wait time including the wait time that has already elapsed. If the new wait time is equal or shorter than the wait time that has already elapsed, the wait operation ends at that point. If the wait time is changed from 00:00:00 to some other value during wait operation, the wait operation starts at that time using the new wait time.

Wait within the Segment

If the PV falls outside the wait zone specified with respect to the current SP when the program operation is within the segment, the operation enters wait mode and the program operation is delayed. For wait operation within the segment, wait operation continues until the PV reaches the wait zone regardless of the wait time setting. When the PV returns within the wait zone, the operation switches from wait operation to run mode and the program operation is resumed. Wait operation is repeated every time the PV falls out of the wait zone.

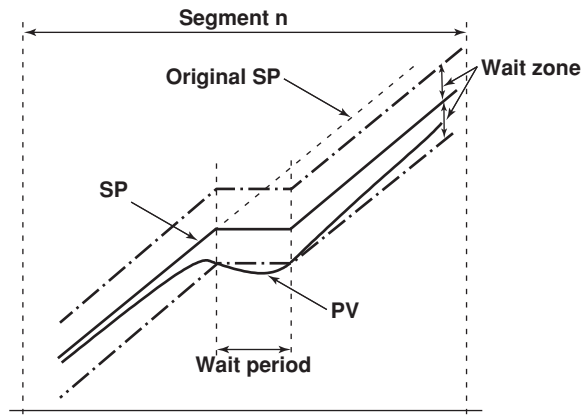

Event Output

This function is used to output an alarm at a preset point in time or turn ON the contact output after a given time elapses. The function operates in sync with the progression of the program operation. The event action operates at the start time of the segment to which the event action is assigned. There are two types of event actions: time event and PV event.

- Number of time events/PV events that can be assigned to a single segment: 16 each.
- Total number of events that can be assigned (total of all patterns): 800

You can set relay output (event output) corresponding to an event action. You can use one of the following types. However, only “event output for each program pattern” is available with versions of the CX earlier than 3.02.

- Common event output setting for all program patterns
- Event output for each program pattern

Time Event

Time event is a function used to turn ON the contact output after a specified time elapses by starting the clock from the time the segment operation is started. The ON time and OFF time are specified in terms of the time elapsed from the start point of the specified segment. You can specify a time exceeding the segment time of the specified segment and event action.

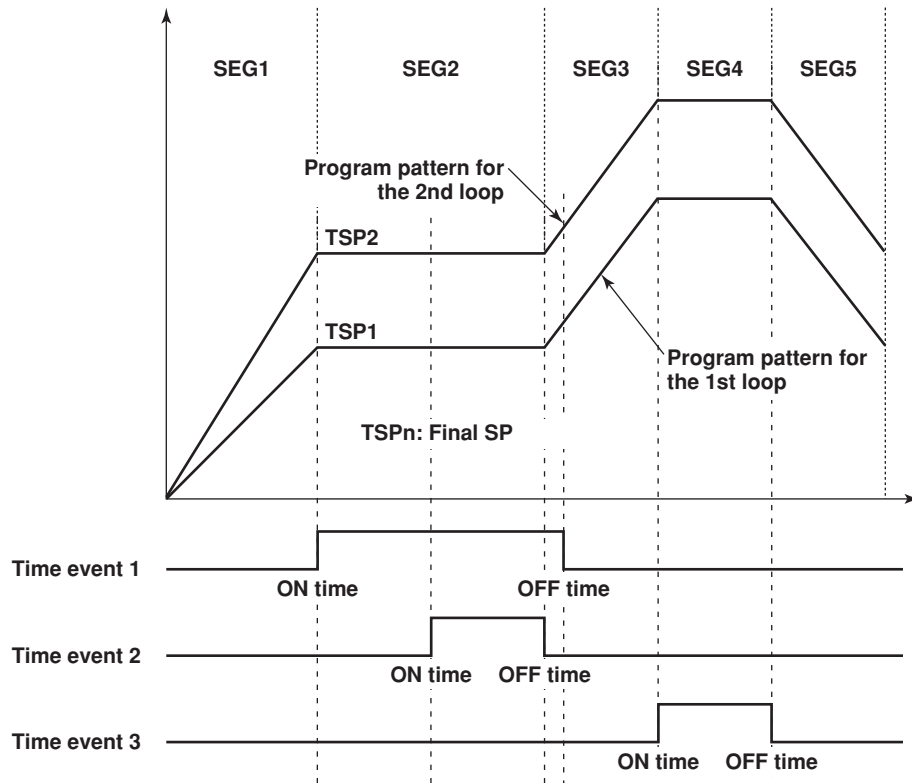

Note

- The event information of the time event is retained even after the segment to which the time event is assigned.
The time event value is retained during hold and wait operation.
- During the hold and wait operations, the time event count is temporarily stopped.
- With the ramp-prioritized PV start, if a pattern starts partway through a segment, the time event also starts partway through.

PV Event

This function outputs preset alarms such as PV alarms and deviation alarms during program operation. PV events operate only within the specified segment.

The following table shows the types of PV events. Hysteresis can be specified for each event.

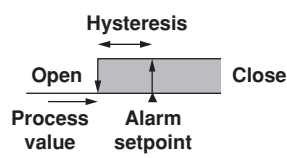
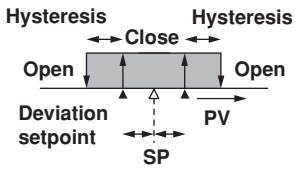
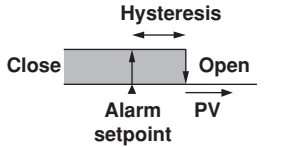
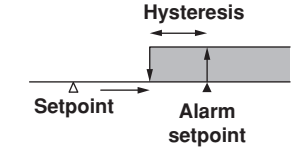
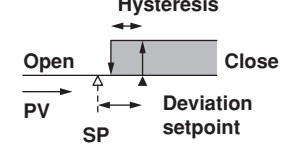
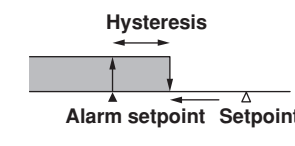
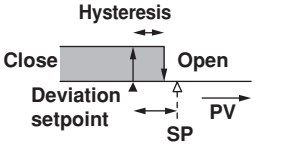
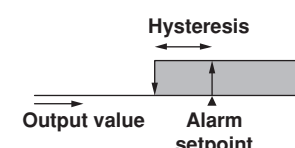
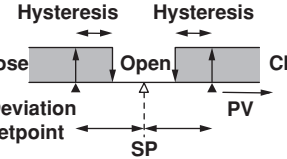
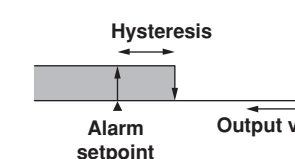
Event type	Relay action (Open/close: relay contact status)	Event type	Relay action (Open/close: relay contact status)
PV high-limit		Deviation within high & low limits	
PV low-limit		SP high-limit	
Deviation high-limit		SP low-limit	
Deviation low-limit		Output high-limit	
Deviation high & low limit		Output low-limit	

Note

- If the setup conditions of PV events are not specified using the same conditions also in the next segment, they are reset at the time the operation of the specified program segment ends.
- With cascade control, you can set PV events to the primary loop and secondary loop.

Switching the Program Pattern Using Contact Inputs

Contact input is applied at [DI001-DI006], [DI101-DI106], and [DI201-DI206] of the control output terminal block, and [RI001-RI006] on the control DIO expansion terminal block.

- Before version 3.02
The program pattern is changed using contact inputs of binary representation.
- Version 3.20 and later
In addition to the binary representation, the program pattern can be changed using contact inputs of binary-coded decimal (BCD) representation. You can select Whether to use [Binary] or [BCD]. The default setting is [Binary].

Repeat Function

This function repeats the operation over a section of the program pattern consisting of continuous segments. To perform repeat operation, you specify the repeat start segment, repeat end segment, and the number of repetitions (repeat count).

Below is a program pattern in which the repeat count = 1, repeat start segment number = 3, and repeat end segment number = 5. You can also specify an infinite number of repetitions.

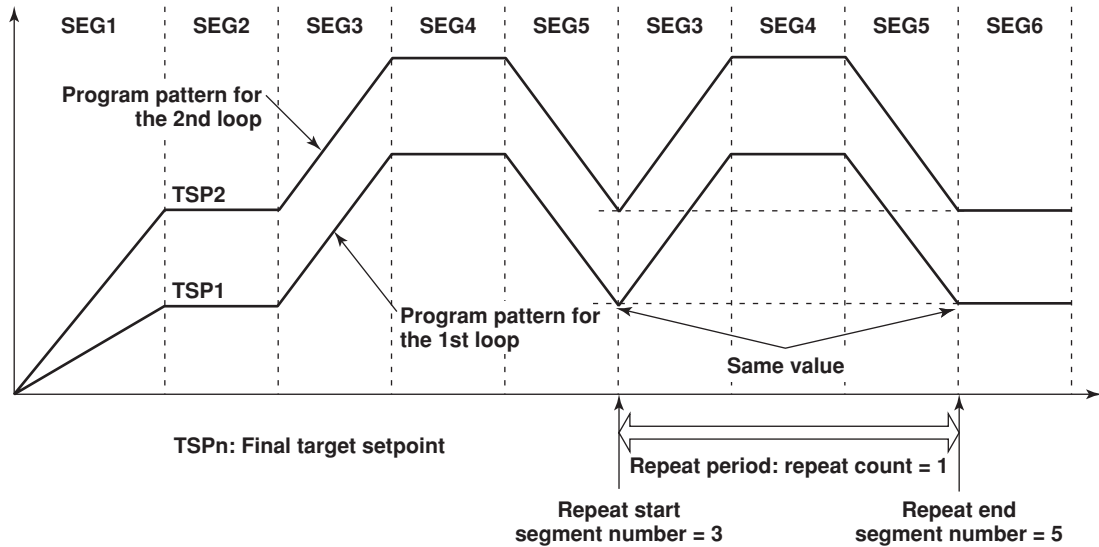

Note

- The operation when repeat action, repeat start segment, repeat end segment, and repeat frequency (including infinity) are changed during program control is indicated below.
- When changed to repeat OFF or when the segment number at that point is larger than the repeat end segment
Repeat action is not performed regardless of the repeat action performed (or not performed) up to that point.
- When the segment number at that point is smaller than the repeat start segment
Repeat action is performed from the first repetition using the new settings regardless of the repeat action performed (or not performed) up to that point.
- When the segment number at that point is between the repeat start segment and repeat end segment
If the change is made before the repeat action is performed (including a change from repeat OFF) or after the repeat action has been finished, repeat action is performed from the first repetition using the new settings. If the change is made during repeat action, the repeat action is performed the number of times specified by the new repeat frequency including the number of repetitions that have been performed before the change. If the new repeat frequency is smaller than or equal to the number of repetitions that have been performed already before the change, the repeat action is terminated after the current repetition. However, if the repeat frequency is changed from infinity to a finite value, repeat action is started using the new repeat frequency from the change point.
- Only a single period of repeat action can be specified for each program pattern.
- Set the first SP of the repeat start segment the same as the last SP of the repeat end segment. If they do not match, the start segment pattern will be affected.
- In repeat action, all time events that are ON are turned OFF when returning from repeat end segment to repeat start segment. If "time-prioritized PV start" or "ramp-prioritized PV start" is specified as a starting condition of the program operation, PV start is also performed when repeat operation is started. However, PV start does not apply to loops in local mode or loops that are stopped. In cascade control, PV start does not apply if the primary loop is in local mode or the secondary loop is stopped. If PV start cannot be carried out, "starting target setpoint start" is carried out.

Program Operation Start Delay

You can set a delay (program start time) in starting the actual program pattern control after carrying out the procedure for starting the program operation. The setting is common to all loops and is valid for a single program operation. The delay cannot be specified during program control. The control output during program control is a preset value. Hold and advance operations cannot be performed while delay is in effect. Selectable range of program start time: 00:00:00 to 99:59:59

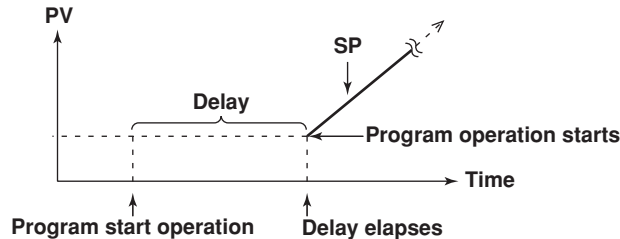

Specifying the Program Operation Start Segment

You can specify the start segment number that is used at the time program operation is started. For example, this function can be used when you wish to set the program currently in operation back to the previous segment and restart the operation. Below is an example in which the operation is started from segment 3.

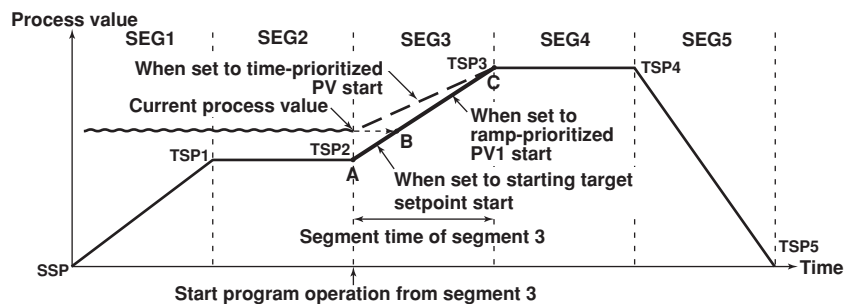

If the program operation is started from segment 3, the program operation starts according to the start conditions as follows.

- When set to starting SP start
The program operates using point A as the starting SP and progresses towards point C.
- When set to ramp-prioritized PV1 start
The program progresses from point B to point C.
- When set to time-prioritized PV start
Program operates from the current PV using the segment time of segment 3 and progresses toward point C.

Hold Operation

You can hold the program progression (stop the timer) during program operation. You can hold the program using key operation on the program operation status display, using the external contact input, or through the communication function. While the program operation is in hold mode, you can temporarily change the settings for the current segment. When hold mode is cleared, the operation continues with the new settings. Temporarily means that the changes take effect in the operation of the current segment, but the setting itself is not changed. The settings that can be changed temporarily are indicated below.

- Change the final SP of the segment.
- Increase or decrease the remaining segment time.

However, if the segment indicated in bold is a ramp segment and the segment time ramp setting method is used, you cannot change only the remaining segment time. If you change the final SP, the remaining segment time changes accordingly.

In addition to releasing the hold mode, executing program RUN operation or executing advance during hold operation also clears the hold mode.

When changing the final SP of the segment

You can change the final SP during the hold operation. The ON/OFF time of the time event and the segment time are prolonged by the amount of time the operation is held.

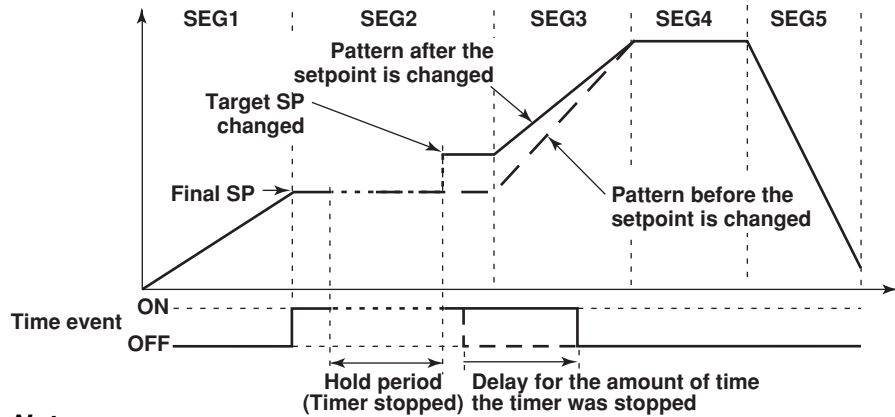

Note

When changing the final SP with the segment time ramp rate assignment method, the segment time is also changed. The time event's event timer is not changed.

When increasing or decreasing the remaining segment time

You can increase or decrease the remaining segment time during the hold operation. If the remaining segment time is increased or decreased during the hold operation, the ON/OFF time and remaining segment time is automatically adjusted by the amount of time the operation is held and the amount of time the segment time is increased or decreased.

- Example in which the remaining segment time is increased

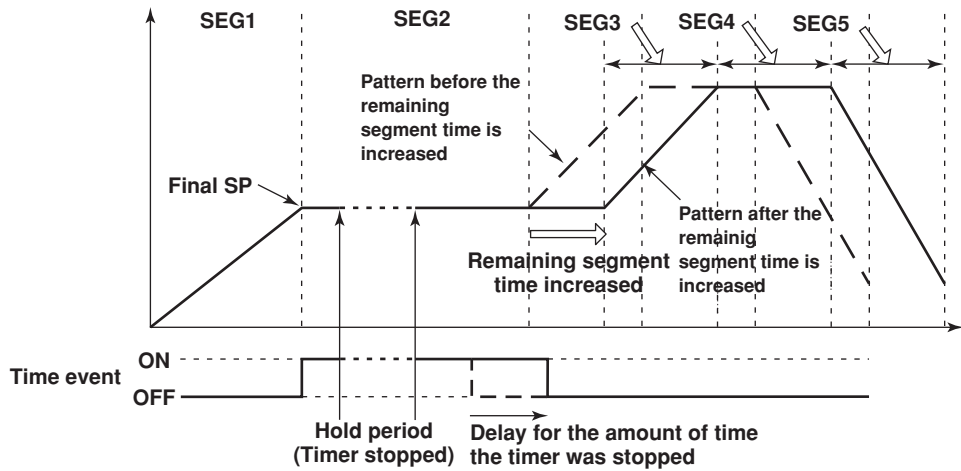

- Example in which the remaining segment time is decreased

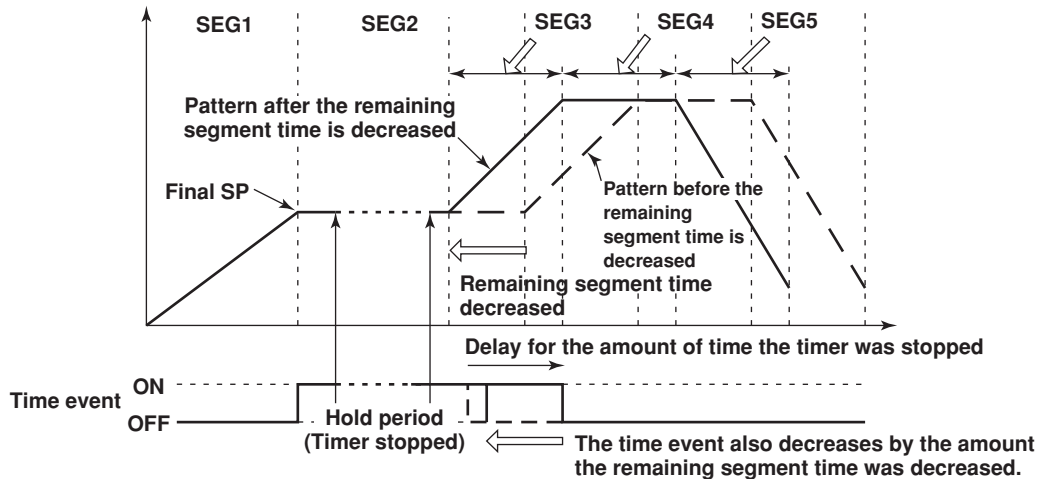

Note

When the remaining segment time is decreased and the event action timer times out, the time event is forcibly generated at that point.

Example in which the final SP is changed using the segment time ramp grade setup method

The figure below shows the example in which both the final SP and the remaining segment time are changed by changing the final SP using the segment time ramp grade setup method.

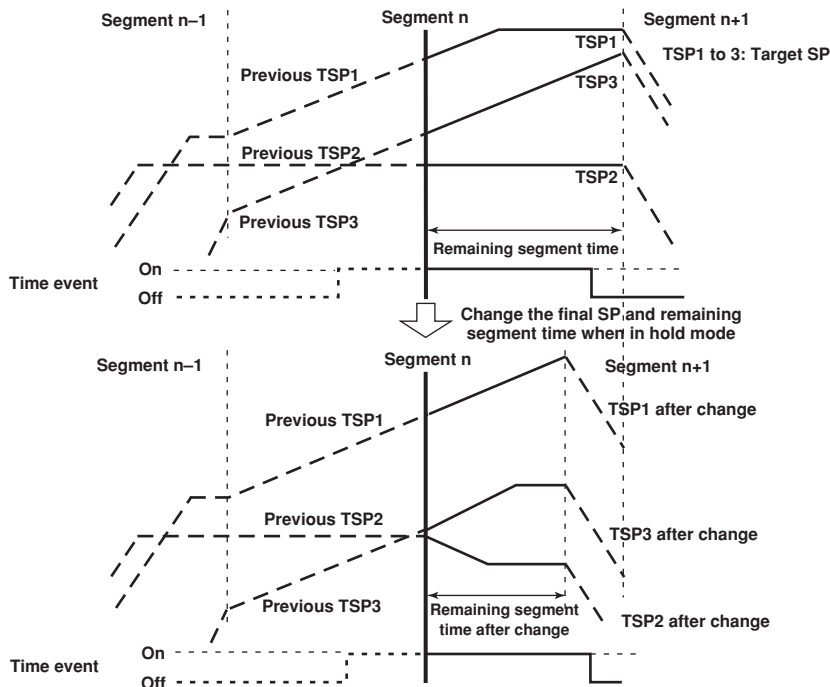
**Advancing Segments**

During program operation, you can force the program to advance to the next segment. You can advance the program using key operation on the program operation status display, using the external contact input, or through the communication function. When you advance the program at the segment currently in operation, the program advances to the next segment. However, depending on the segment at which this function is executed, the following operation may take place.

- When advance is executed at the last segment
 - The program operates according to the switching settings of the segment.
 - When set to [Local]: The operation enters local mode
 - When set to [Reset]: The operation enters reset mode (operation stop)
 - When set to [Continuous] or [Hold]: The operation enters reset mode (operation stop)
- When advance is executed at the repeat end segment
 - Repeat operation is started.
- When advance is executed at a segment other than those described above
 - The program advances to the next segment regardless of the segment switching settings.
- When advance is executed when the program operation is on hold
 - The hold mode is cleared, and the program operates according to the segment conditions described above.

Program pattern end signal

When program control terminates normally (excluding forced termination), the termination can be notified using contact output (also through communication function). The contact output is turn ON for 5 s after normal termination.

1.12 Tuning

Selecting Tuning Parameters

Up to 21 tuning parameters can be shown on the tuning display. The parameters are initially assigned as shown below. The name of the tuning parameters (such as SP) can be changed using up to 6 characters. In addition to the tuning parameters below, [DR] (control direction) and [H] (relay hysteresis) are available.

- | | | |
|------------------------------|--|--|
| SP (target setpoint) | D (derivative time) | BS1 (measured value 1 input bias)* |
| A1 (alarm 1 setpoint) | OH (High limit of the output limiter) | FL1 (measured value 1 input filter)* |
| A2 (alarm 2 setpoint) | OL (Low limit of the output limiter) | BS2 (measured value 2 input bias)* |
| A3 (alarm 3 setpoint) | MR (manual reset) | FL2 (measured value 2 input filter)* |
| A4 (alarm 4 setpoint) | PO (preset output) | RT (ratio setting)* |
| P (proportional band) | | RBS (remote input bias)* |
| I (integral time) | | RFL (remote input filter)* |
| | | W01 to W36
(control computation constant)* |

* Applies to style number S3 or later
BS1, FL1, BS2, FL2, RFL, and W01-W36 cannot be selected when PV/SP computation is ON.

Manual Tuning Operation

On the tuning display as shown below, you can select the parameter you wish to tune using the arrow keys and change the value.

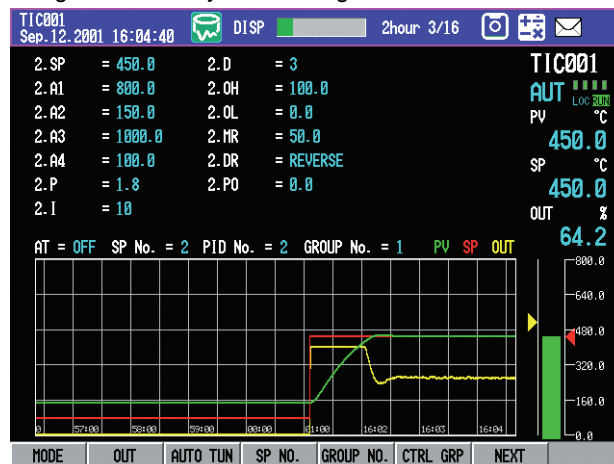

Auto Tuning the PID Constant

On the tuning display, select the PID number you wish to auto-tune and execute auto tuning.

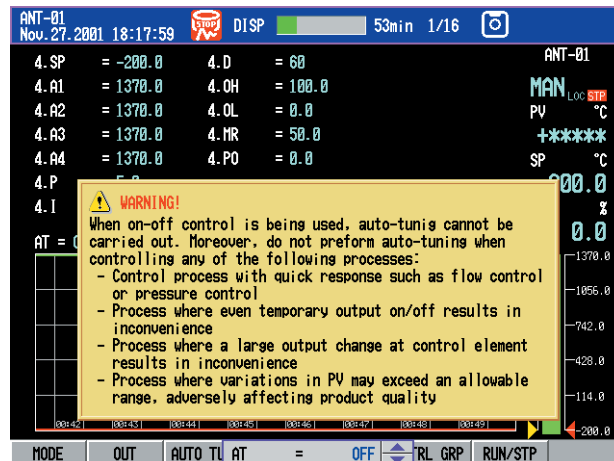

Auto Tuning

Auto tuning is a function that automatically measures the process characteristics and automatically sets the optimum PID constant. When auto tuning is executed, the control output is temporarily turned ON/OFF step-wise (see the following figure). From the hunting period and amplitude of the PV that is generated, the optimum PID constant is calculated and set. This method is called the limit cycle method. Auto-tuning is allowed only during auto operation under PID control. In addition, for cascade control, auto tuning on the primary loop is possible only when cascade operation is in progress.

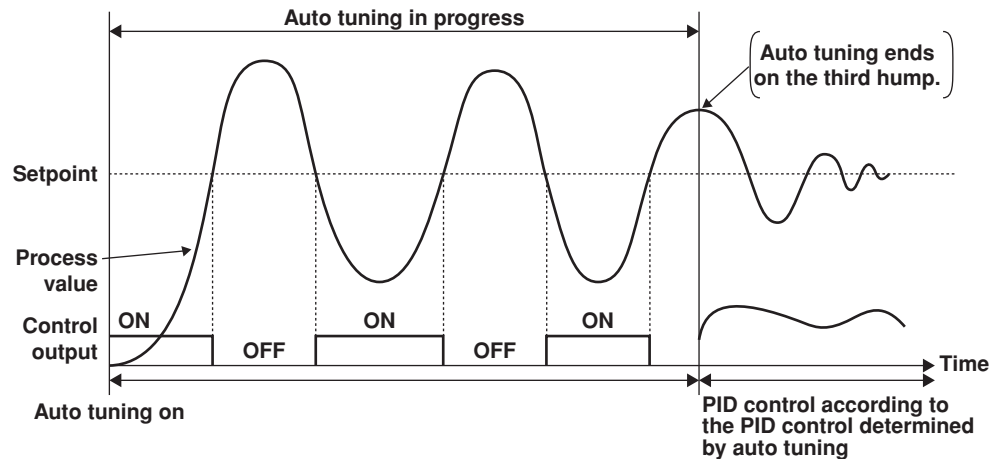
**Target Setpoint during Auto Tuning Execution (Auto Tuning Point)**

The auto tuning point can be limited in the range of 3 to 97% of the measurement span. Auto tuning points are indicated below.

- When Zone PID is selected
 - Local operation
 - When specified group is in operation: SP specified by the SP number
 - When all groups are in operation: Midpoint of each reference point
 - Program operation or remote operation
 - When specified group is in operation: SP when auto tuning is executed
 - When all groups are in operation: Midpoint of each reference point
- When Zone PID is not selected
 - Local operation
 - SP specified by the SP number
 - Program operation or remote operation
 - SP when auto tuning is executed

(However, the secondary loop of cascade control is the SP specified by the SP number)

Note

If auto tuning is executed when any of the loops set to program control enabled (includes the case when program control is enabled on the primary loop of cascade control) is in program operation, the progress of the program operation is temporarily paused. The time event and segment time are prolonged by the amount of time the program operation is paused. The program operation is resumed when auto tuning on all loops set to program control enabled is complete. When program operation is temporarily paused, hole operation, advance operation, and PV event are valid. However, wait operation is invalid.

1.13 Measurement Function Overview

Measurement Input

DC voltage, thermocouple, resistance temperature detector, or ON/OFF signal (contact signal or voltage signal) can be measured. The input signal is A/D-converted at a scan interval of 1 s or 2 s and acquired to the internal memory. In addition, difference computation, square-root computation, and scaling can be carried out on the measured data and acquired to the internal memory.

Displaying the Measured Data

The measured data acquired to the internal memory can be displayed on the operation display using trend waveforms, numeric values (digital values), or bar graphs.

Trend Display

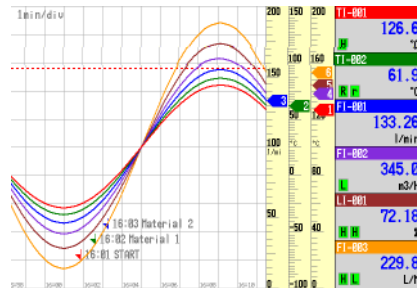

Digital Display

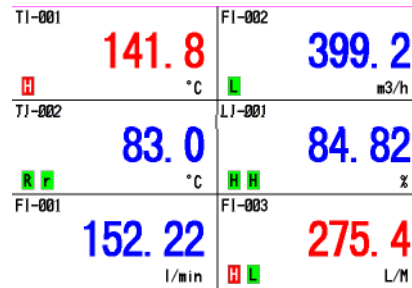

Bar Graph Display

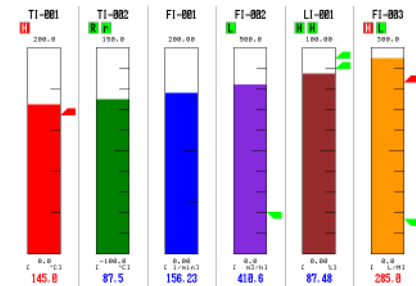

4 Screen Display

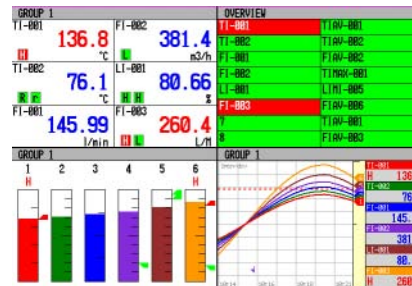

Measurement Alarms

Alarms can be generated when the measured/computed data meets a certain condition. When an alarm occurs, you can have the information about the alarm displayed on the operation display. Also, you can output relay signals from the alarm output terminal (ALARM) on the measurement alarm option terminal block, the control output terminal block, the relay contact output on the control DIO expansion terminal block, or the transistor output terminal (DIGITAL OUT). You can also turn the internal switches ON. On the operation display, the alarm status is displayed as alarm icons in the status display section and using methods such as the trend, digital, bar graph, overview displays. The detailed information about the alarms is displayed in the alarm summary.

Alarm Indication Example on the Overview Display

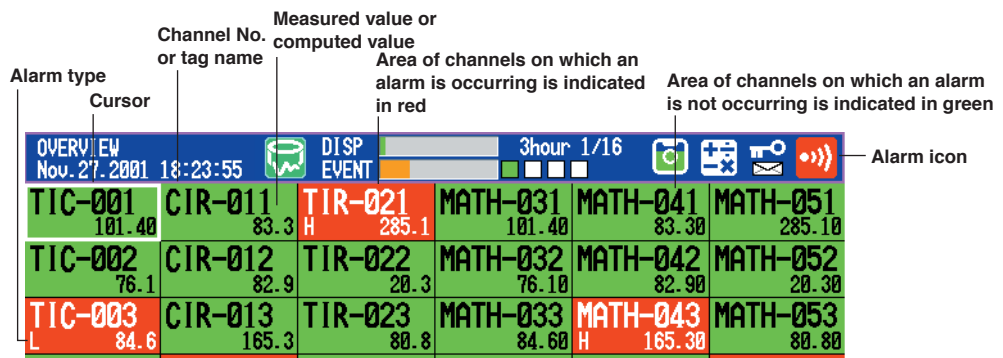

Alarm Summary Display Example(For details, see page 1-82)

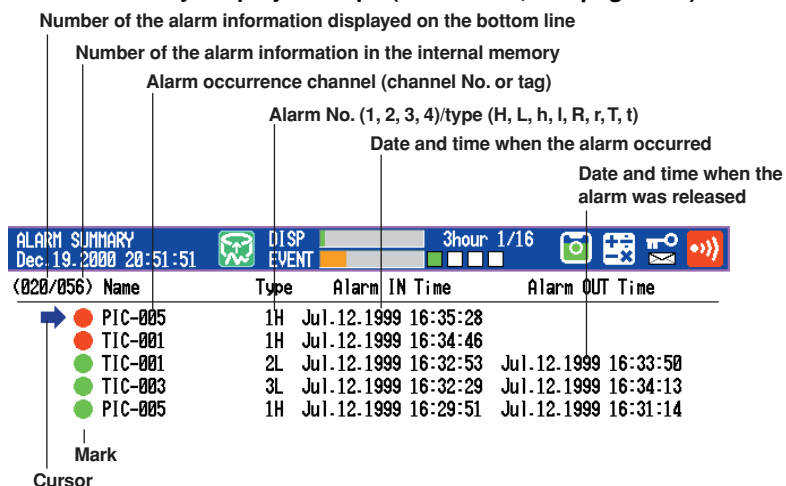

Saving Data

The measured data can also be saved to external storage media such as floppy disks (2HD), Zip disks (100 MB or 250 MB), and ATA flash memory cards (4 to 440 MB).

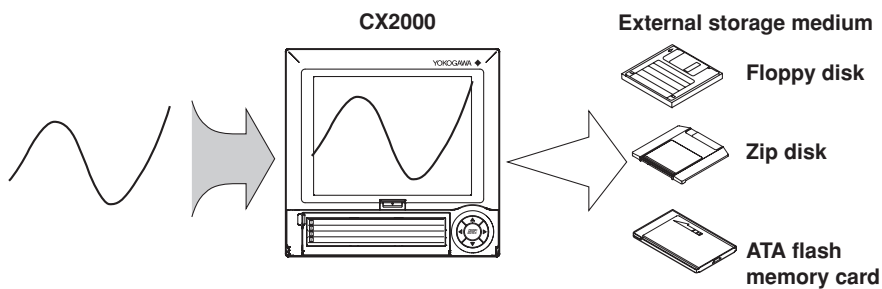

The data that has been saved to an external storage medium can be displayed on a PC using the DAQSTANDARD software that comes with the package. The data can also be loaded into the CX2000 to be displayed.

Communication Function

By using the Ethernet interface that comes standard with the CX2000, the data can be transferred to a server on a network (client function). The data stored on the CX2000's external storage medium can also be read from a PC on the network (server function).

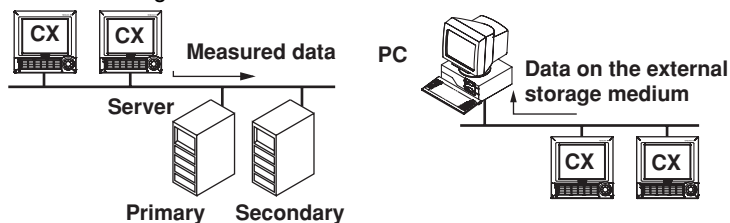

The communication functions using the Ethernet or serial interface are not covered in this manual. See the *DAQSTATION CX1000/CX2000 Communication Interface User's Manual (IM 04L31A01-17E)*.

1.14 Measurement Function > Measurement Input Related Settings

Integration Time of the A/D Converter

The CX2000 uses an A/D converter to convert the sampled analog signal to a digital signal. At this point, the sampled data is integrated for a certain period to eliminate the noise that is mixed in the input signal. You can select the integral time from [Auto]/[50Hz(20ms)]/[60Hz(16.7ms)]/100ms]. This setting applies not only to the measurement input of the measurement function but also to the PV input of the control function. By setting the integration time of the A/D converter to match the time period corresponding to one cycle of the power supply or an integer multiple of one cycle, the power supply frequency noise can be effectively eliminated. If [Auto] is selected, the recorder will automatically detect the power supply frequency and select 16.7 ms or 20 ms. Because 100 ms is an integer multiple of 16.7 ms and 20 ms, this setting can be used to eliminate the power frequency noise for either frequency, 50 Hz or 60 Hz.

Scan Interval

The scan interval is the interval used to sample the input signal. You can select [1s] or [2s]. However, if the integral time is set to [100ms], the scan interval is fixed to 2 s.

Note

When performing four arithmetic operations on models with the computation function (/M1), this scan interval is used to carry out the computation.

Input Type and Input Computation (Mode)

If the last two digits of the CX2000 model that you are using are 1 and 0, there are 10 channels of measurement input channels (measurement channels); if they are 2 and 0, there are 20 channels. You can select the type of signal input to each measurement channel from DC voltage, thermocouple, resistance temperature detector, and ON/OFF input (contact signal or voltage signal). In addition, difference computation, square-root computation, and scaling can be performed on the measured data and display or save the computed result as measured data. On the CX2000, the input type and input computation type is set as a [Mode]. In addition, if [Mode] is set to difference computation, square-root computation, or scaling, the input type is set as a [Type].

Mode	Notation in Setup*	Description
DC voltage	Voltage	Measures a DC voltage in the range of ± 20 mV to ± 50 V.
Thermocouple	TC	Measures temperatures corresponding to the temperature range of each thermocouple type such as R, S, B, K, E, J, T, N, and W.
Resistance temperature detector	RTD	Measures temperatures corresponding to the appropriate range for Pt100 or JPt100.
Scaling	Scale	The input signal can be scaled to a value in the appropriate unit and displayed. You can select the input type from DC voltage, thermocouple, resistance temperature detector, and ON/OFF input.
Difference	Delta	Displays the value obtained by subtracting the measured value of another channel (called the reference channel) from the input signal of the specified channel as the measured value for the specified channel. You can select the input type from DC voltage, thermocouple, resistance temperature detector, and ON/OFF input.
ON/OFF input	DI	Displays the contact input or voltage input signals by correlating them to 0% or 100% of the display range. Contact input: Closed contact is ON (1). Open contact is OFF (0). Voltage input: Less than 2.4 V is OFF (0). Greater than or equal to 2.4 V is ON (1)
Square root computation	Sqrt	Calculates the square root of the input signal and displays the result as the measured value of the channel. The computed result can also be scaled to a value in the appropriate unit and displayed. The input type is DC voltage only.
Skip	Skip	Disables the channel.

* Characters displayed as selections in the [Mode] box of the setting display. It is used when setting the measurement channels.

Note

- For current inputs, a shunt resistor is attached to the input terminal to convert the signal to voltage input. The following table shows the available shunt resistors. For example, a 250-Ω shunt resistor is used to convert the signal to 1 to 5 V for 4-20 mA input.

Name	Model	Resistance
Shunt resistor	4159 20	250 Ω ± 0.1%
(for screw terminals)	4159 21	100 Ω ± 0.1%
	4159 22	10 Ω ± 0.1%

- The square-root computation method of the CX2000 is indicated below.

$$F_x = (F_{max} - F_{min}) \sqrt{\frac{V_x - V_{min}}{V_{max} - V_{min}}} + F_{min}$$

Meanings of the symbols are shown below.

V_{min} : span lower limit, V_{max} : span upper limit, F_{min} : scale lower limit after conversion,

F_{max} : scale upper limit after conversion, V_x : input voltage, F_x : scaling value.

If the value inside the root is negative, the computed result is displayed as follows.

When $F_{min} < F_{max}$: “-*****”

When $F_{min} > F_{max}$: “+*****”

Input Range and Measurable Range

When the input type is set to DC voltage, thermocouple, resistance temperature detector, or ON/OFF input, you will select the range to match the input signal. For DC voltage, select the measurable range (select [20mV] for “-20.00 to 20.00 mV”). For thermocouple or resistance temperature detector, select the type. For example, the type selections for the thermocouple are [R], [S], [B], [K], [E], [J], [T], [N], [W], [L], [U], [PLATINEL], [PR40-20], and [W3Re/W25Re]. If [R] is selected, the measurable range is 0.0 °C to 176.0 °C. In addition, you will set the measurement span ([Span lower limit] and [Span high limit]) within the measurable range as the actual range for making measurements.

Burnout Detection

When measuring the temperature using a thermocouple, you can have the measurement result set to positive overrange^{*1} or negative overrange^{*2} when a burnout occurs. Burnout can be set on each measurement channel. The initial setting is set so that burnout is not detected.

*1 Positive overrange refers to the condition in which the input signal is exceeding the upper limit of the measurable range of the input range. The measured value is show as “+*****”.

*2 Negative overrange refers to the condition in which the input signal is less than the lower limit of the measurable range of the input range. The measured value is show as “-*****”.

Reference Junction Compensation

When measuring the temperature using a thermocouple, the reference junction compensation can be used. You can select whether to use the reference junction compensation provided by the CX2000 or an external reference junction compensation. If you are using an external reference junction compensation, you will also set the reference voltage. The initial setting is set so that the reference junction compensation provided by the CX2000 is used. When using the external reference junction compensation, set an appropriate reference junction compensation voltage. As in the example in the following figure, if the reference junction temperature for the external reference junction compensation is T_0 °C, set the thermoelectromotive force of the 0-°C reference for T_0 °C as the reference junction compensation voltage.

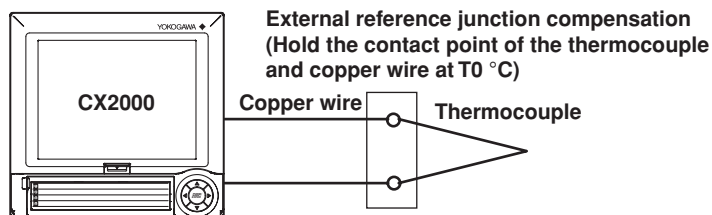

Moving Average

The moving average is used to suppress the effects of noise that is riding on the signal. The input signal of the measurement channel is set to the averaged value of the *m* most current data points (the number of moving-averaged data points) acquired using the scan interval. The number of moving-averaged data points (*m*) can be set in the range 2 to 16. The figure below shows an example indicating the operation of the buffer for the moving average computation when the number of moving averaged data points is set to "5." The moving average can be set on each channel. The moving average is initially turned OFF.

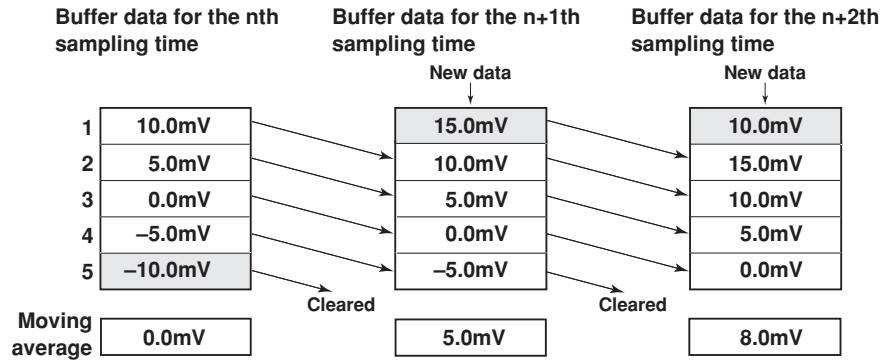

1.15 Measurement Function > Measurement Alarm Related Settings

Turning ON/OFF the Alarm

You can set up to four alarms for each channel. You can set alarms not only on measurement channels but also computation channels. For each alarm, you can set different alarm conditions.

Alarm Conditions

The following eight conditions (shown as [Type] on the setting display) are available.

- **Upper limit alarm**
An alarm occurs when the measured/computed value exceeds the alarm value.
- **Lower limit alarm**
An alarm occurs when the measured/computed value falls below the alarm value.

Upper limit alarm

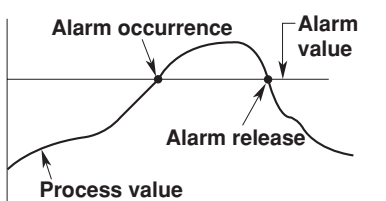

Lower limit alarm

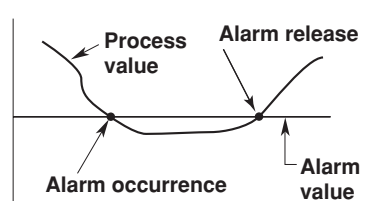

- **Difference upper limit alarm** (can be set on difference computation channels only)
An alarm occurs when the difference in the measured values of two channels exceeds the difference upper limit alarm value.
- **Difference lower limit alarm** (can be set on difference computation channels only)
An alarm occurs when the difference in the measured values of two channels falls below the difference upper limit alarm value.
- **Upper limit on rate-of-change alarm** (can be set on measurement channels only)
The rate-of-change of the measured values is checked over a certain time (interval). An alarm occurs if the rate-of-change of the measured value in the rising direction exceeds the specified value.
- **Lower limit on rate-of-change alarm** (can be set on measurement channels only)
The rate-of-change of the measured values is checked over a certain time (interval). An alarm occurs if the rate-of-change of the measured value in the falling direction exceeds the specified value.

Upper limit on rate-of-change alarm

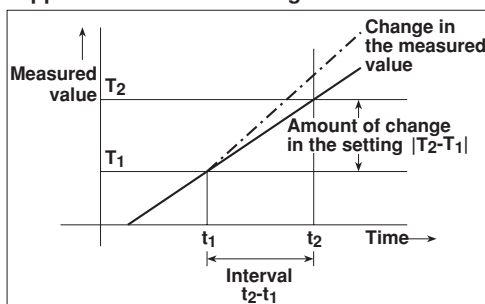

Lower limit on rate-of-change alarm

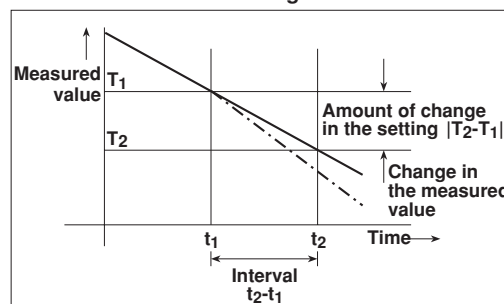

The alarm value of the rate-of-change alarm is set using an absolute value. The interval is derived using the following equation and set using the number of sampled data.

$$\text{Interval} = \text{Scan interval} \times \text{number of sampled data}$$

- **Delay upper limit alarm**
An alarm occurs when the measured/computed value remains above the alarm value for the specified time (delay).

- **Delay lower limit alarm**

An alarm occurs when the measured/computed value remains below the alarm value for the specified time (delay).

Delay upper limit alarm example (T is the specified delay)

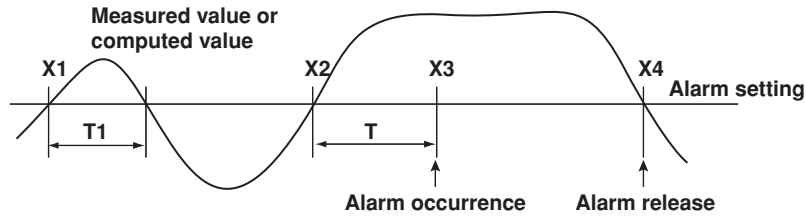

- Alarm does not occur at T1, because the time is shorter than the specified delay (T).
- The input exceeds the alarm value at X2, but the alarm occurs at X3 at which the specified delay period elapses (the time when the alarm occurs is the time at X3).
- The input falls below the alarm value at X4 and the alarm is released.

Note

The following special operations are available for the delay upper/lower limit alarm.

- **When a delay alarm is set on a computation channel and the computation is stopped**

If the computation is stopped in a condition in which the computed value is exceeding the alarm setting, the alarm is turned ON after the specified period (delay period) elapses.

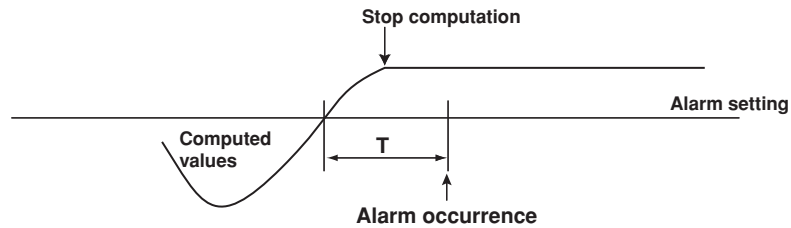

- **Delay alarm when a power failure occurs**

Alarm detection is reset upon a power failure. It restarts the operation after the power recovers.

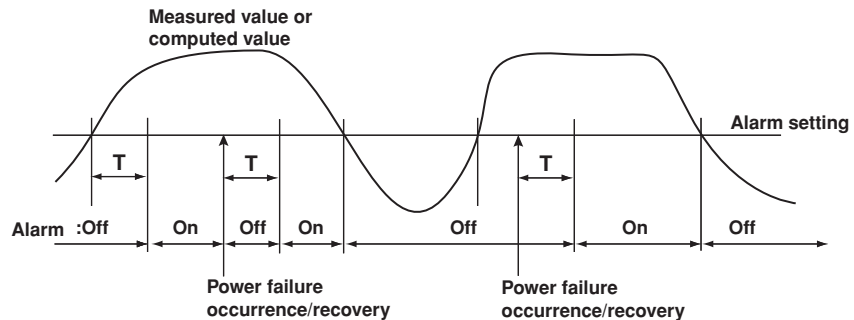

- **Operation when the alarm setting is changed**

- When a new delay alarm is set
 - The alarm detection starts at the time the alarm is set. It is unaffected by the conditions existing before the alarm is set.
- If the alarm setting of a preexisting delay alarm is changed
 - If an alarm is not occurring at the time of the change, alarm detection starts at the new setting.
 - If an alarm is occurring at the time of the change and the alarm type is set to delay upper limit alarm, the alarm continues as long as the input is above or equal to the new setting. If the input is below the new setting, the alarm turns OFF. If the alarm type is set to delay lower limit alarm, the alarm continues as long as the input is below or equal to the new setting. If the input is greater than the new setting, the alarm turns OFF.

Alarm Hysteresis

You can set a width (hysteresis) to the values used to activate and release alarms. Alarm hysteresis prevents frequent activation and release of alarms when the measured value is unstable around the alarm value. The hysteresis is fixed to 0.5% of the measurement span (display scale width if the range is set to scale).

It is applied only on alarms set to upper/lower limit alarm on measurement channels, and the function can be turned ON/OFF.

Factory default setting: Hysteresis ON

Upper limit alarm

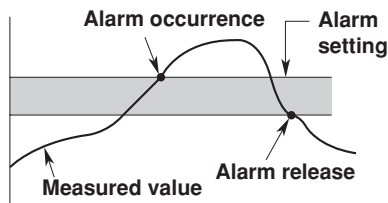

Lower limit alarm

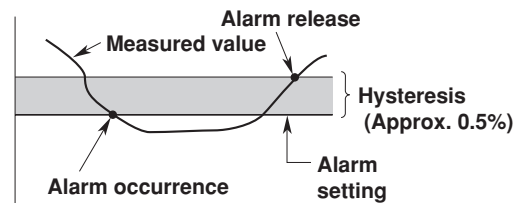

Alarm Relay Output

Relay Output ON/OFF

When an alarm occurs, you can output relay signals from the alarm output terminal (ALARM) on the measurement alarm option terminal block, the control output terminal block, the relay contact output on the control DIO expansion terminal block, or the transistor output terminal (DIGITAL OUT). You can also turn the internal switches ON (style number S3 or later).

Reflash Alarm

This function is used to notify alarms occurring after the relay is activated on the first alarm when multiple alarms are assigned to a single alarm output relay. When this function is turned ON, the output relay is temporarily (approx. 500 ms) released when alarms after the first alarm occur. The initial setting is [Off] (not use reflash alarm). The reflash alarm function is set only on output relays I01, I02, and I03.

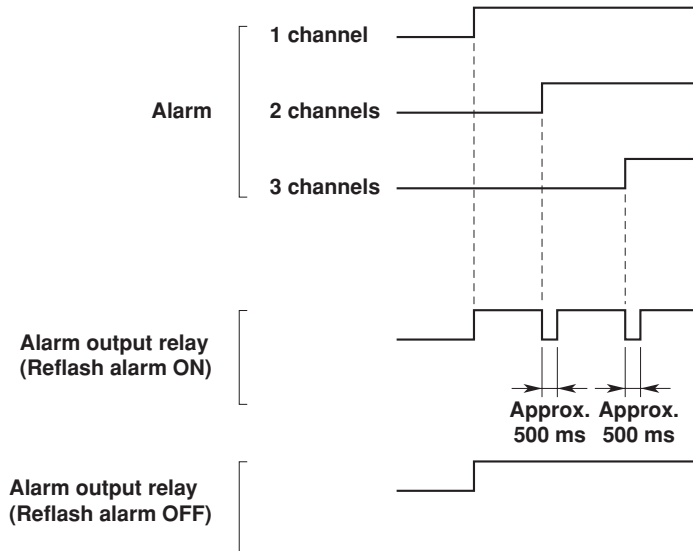

Note

If the reflash alarm is set, I01 to I03 become dedicated reflash alarms regardless of the number of alarm output relays. Therefore, relays I01 to I03 operate as OR logic (see "AND/OR of Alarm Output Relays") and non-hold (see "Hold/Non-hold Operation of Alarm Output Relays") regardless of the settings made in "AND/OR of alarm output relays" and "Hold/Non-hold operation of the alarm output relay."

AND/OR of Alarm Output Relays

When a single alarm relay is shared among multiple alarms, you can select either condition below to activate the alarm output relay.

- AND: Activated when all assigned alarms are occurring simultaneously.
- OR: Activated when any of the specified alarms is occurring.

Set the alarm output relays for taking the AND logic in the following fashion: "I01 (first relay) to Ixx (where xx is the relay number)." The value is initially set to [None] (no AND relay).

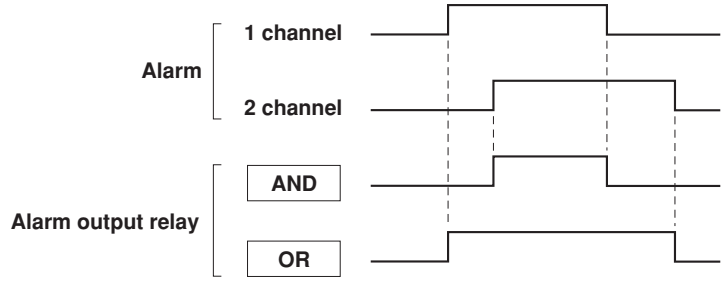

Note

When the reflash alarm is turned ON, I01 to I03 operates as reflash alarms. They are fixed to OR logic operation. Specifying AND produces no effect.

Energized/De-energized Operation of Alarm Output Relays

You can select whether the alarm output relay is energized or de-energized when an alarm occurs. If de-energized is selected, the alarm output relay behaves in the same fashion as when an alarm occurs if the power is shut down. The setting applies to all alarm outputs. The initial setting is [Energized].

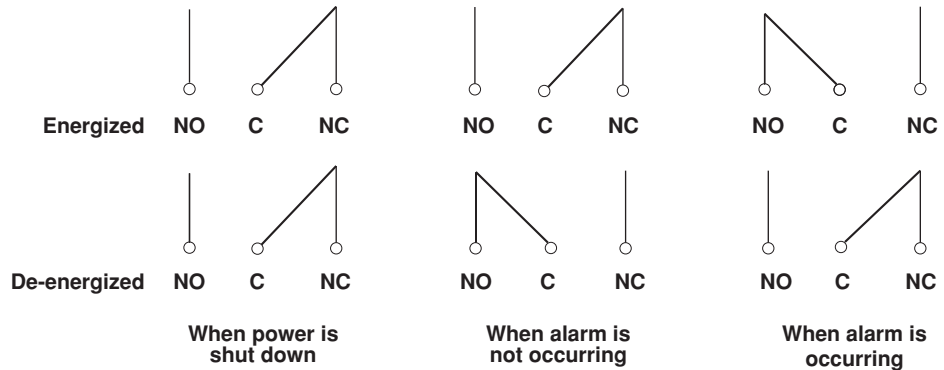

NO: Normally Opened, C: Common, NC: Normally Closed

Hold/Non-hold Operation of Alarm Output Relays

You can select the following behavior when the alarm switches from the activated condition to the released condition (reverts to the normal condition).

- Turn OFF the output relay with the release of the alarm (non-hold).
- Hold the output relay at ON until an alarm ACK operation is performed (hold).

The setting applies to all alarm output relays. The initial setting is [Non-hold].

When set to non-hold

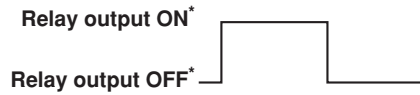
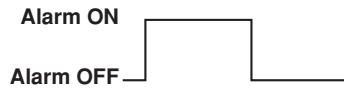

* Relay output ON/OFF is for the case when NO (Normally Opened) terminal is used. If a NC (Normally Closed) terminal is used, the ON/OFF condition is reversed from the condition shown in the left figure.

When set to hold

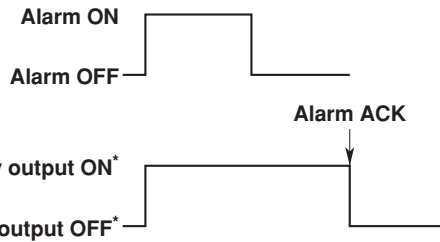

Note

When the reflash alarm is turned ON, I01 to I03 are set to non-hold. Specifying [Hold] produces no effect.

Hold/Non-hold of Alarm Indications

You can select the following behavior when the alarm switches from the activated condition to the released condition.

- Clear the alarm indication with the release of the alarm (non-hold).
- Hold the alarm indication until the alarm ACK operation is performed (hold).

The initial setting is [Non-hold].

Alarm Icon Indication Example

When indication is set to non-hold

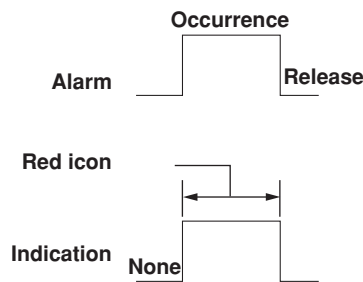

When indication is set to hold

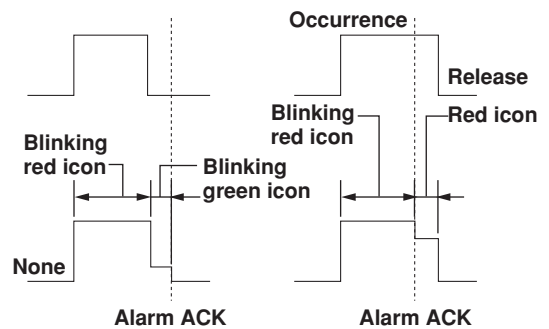

Note

The non-hold/hold setting of the alarm indication also applies to control alarms.

Showing/Hiding the Alarm Display (Style Number S3 or Later)

You can select whether or not to display alarms when they occur. When not displaying alarms, the alarm is output but not retained in the alarm summary.

1.16 Display Function

Display Types and Switching Operation

As indicated in the following figure, key operation is used to switch the displays.

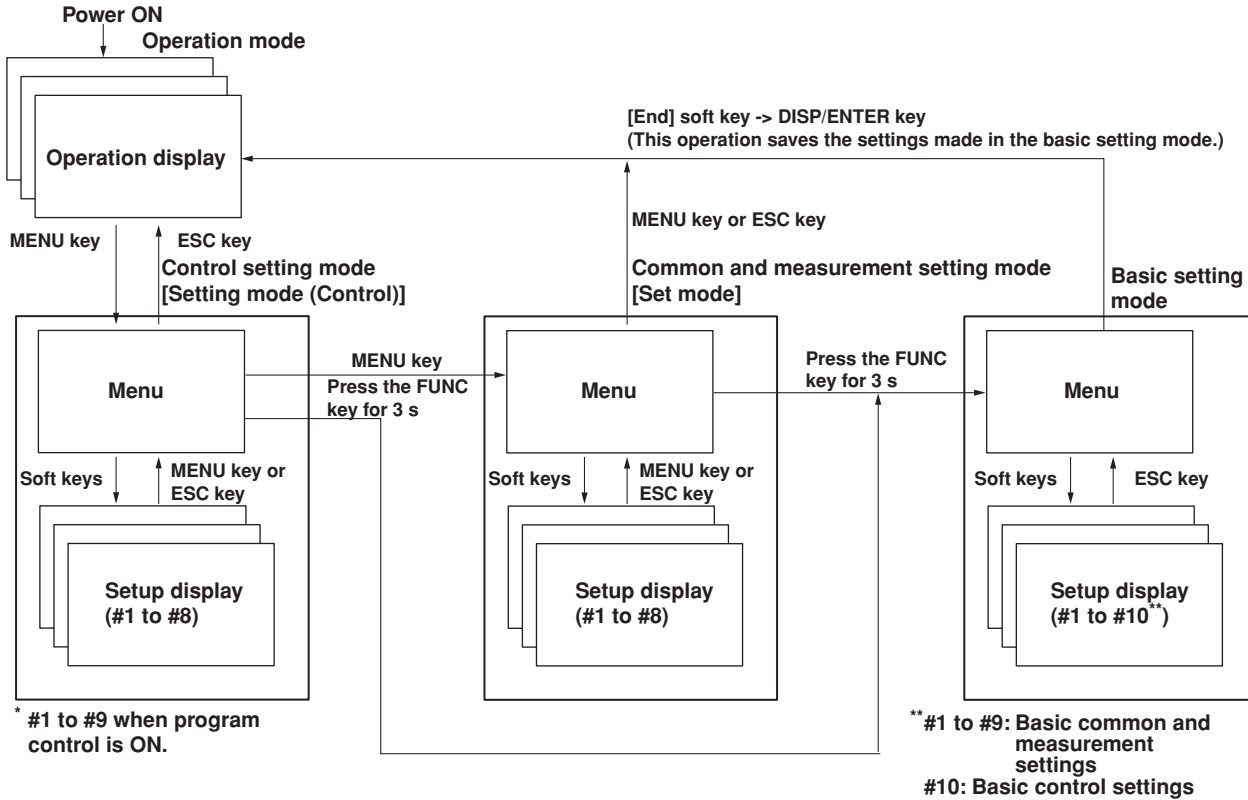

Menu

This display is used to select the necessary setup items.

- Selection Display for Control Related Setup Items

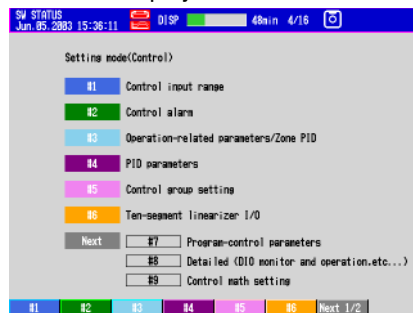

Setting Display

This display is used to set various parameters for the selected item.

- Control Input Range Setting Display

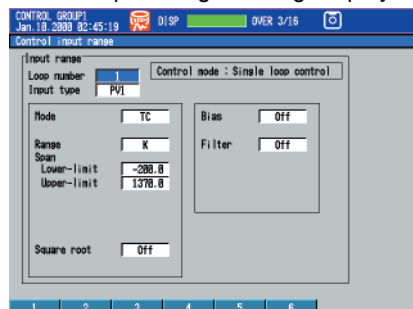

Operation Display

This display is used to monitor the operation status and carry out control operations such as running and stopping the operation.

- Control Group Display (Controller Style) for Monitoring the Control Status and Performing Control Operations



- Trend Display of Measured Data

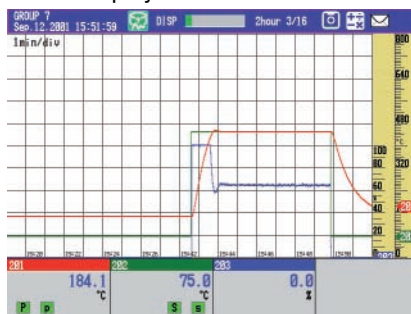

Display Construction

The display consists of the operation status indication section, data display section, and the soft key menu. However, on the measurement operation display, the [FUNC] key must be pressed to show the soft key menu.

[Control Group Display (Faceplate Style) Example]

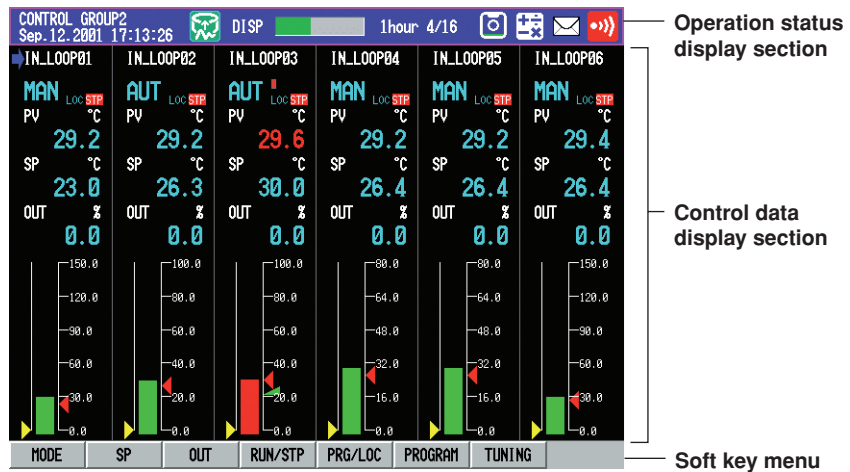

- **Operation Status Indication Section**

The following information is displayed in the status display section during operation mode and setting mode. (The information is not displayed during basic setting mode. [Setup Mode] is displayed instead.)

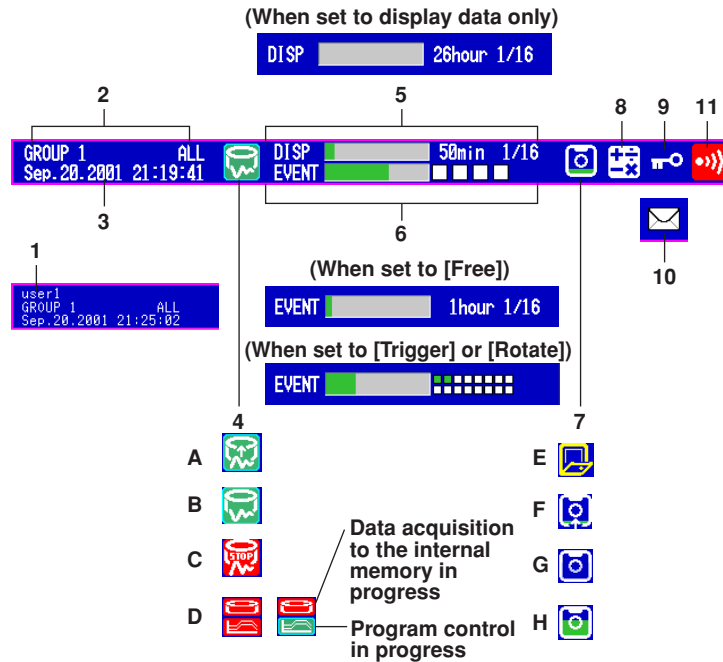

1. User name

The user name is displayed when the key login function is used and the user is logged in.

2. Group name or display name

The display name or group name corresponding to the display shown on the data display section. [ALL] is displayed only when all channels are displayed on the trend display.

3. Current date and time

The current date and time are displayed.

On models with the optional /BT1 batch header, the “date and time” and “batch number and lot number” are alternately displayed every 5 s when “Use Batch Header” (see section 11.6) is being set.

4. Data acquisition to the internal memory ON/OFF

A and B is alternately displayed: Data being acquired or waiting for a trigger for event data.

C: Data acquisition stopped

D: When the control mode is set to a mode other than [Off] and the program control is ON, program control RESET (red)/RUN (green) status is indicated in addition to the ON/OFF status of the data acquisition to the internal memory.

Note

For event data that starts sampling when the trigger condition is met, the display indicates that sampling is in progress even in the trigger wait state. The trigger wait state can be determined on the bar graph.

5. Memory usage of the display data acquisition area in the internal memory

Displayed when acquisition of display data is enabled.

- Bar graph
Indicates the amount of display data acquisition area that is being used.
- Time display
Remaining time of the display data acquisition area. When the remaining time becomes short, the time is displayed in units of minutes.

Remaining time	Unit
100 days or more	% (Percentage of the remaining area in the display data acquisition area)
100 hours or more to less than 100 days	Days (time unit less than one day is truncated)
60 minutes or more to less than 100 hours	Hours (time unit less than one hour is truncated)
Less than 60 minutes	Minutes (time unit less than one minute is truncated)

- n/16
The maximum number of display data files that can be written to the internal memory is 16. "16" represents this value.
The value n is the number of display data files in the internal memory.

Note

In the following cases, the display data is overwritten from the oldest file. Use caution because the overwritten data is lost forever.

- When there is no more remaining time of the display data acquisition area in the internal memory
At this point, the status display section shows [Overwrite].
- When the number of display data files in the internal memory has exceeded 16

6. Memory usage of the event data acquisition area in the internal memory

Displayed when acquisition of event data is enabled.

- When the acquisition mode is [Free]
 - Bar graph
Indicates the amount of event data acquisition area that is being used.
 - Time display
Remaining time of the event data acquisition area. When the remaining time becomes short, the time is displayed in units of minutes.

Remaining time	Unit
100 days or more	% (Percentage of the remaining area in the event data acquisition area)
100 hours or more to less than 100 days	Days (time unit less than one day is truncated)
60 minutes or more to less than 100 hours	Hours (time unit less than one hour is truncated)
Less than 60 minutes	Minutes (time unit less than one minute is truncated)

- n/16
The maximum number of event data files that can be written to the internal memory is 16. "16" represents this value.
The value n is the number of event data files in the internal memory.

Note

In the following cases, the event data is overwritten from the oldest file. Use caution because the overwritten data is lost forever.

- When there is no more remaining time of the event data acquisition area in the internal memory
The status display section shows [Overwrite].
- When the number of event data files in the internal memory has exceeded 16

- When the mode is [Trigger] or [Rotate]
 - Bar graph
Displays the acquisition time (amount of memory used with respect to the data length) of the specified event data.
When pretrigger is specified and START is pressed causing the CX2000 to enter the trigger wait state, data of size equal to the pretrigger amount is acquired to the internal memory. At this point the bar is displayed in orange. After acquiring the data of size equal to the pretrigger, the length of the bar stays fixed. However, the relevant data is updated until the trigger condition is met. When the trigger condition is met, the bar turns green. Data is acquired to the internal memory after the pretrigger data.
If data acquisition to all blocks is finished in [Trigger] mode, [Full] is displayed in the bar. When [Full] is displayed, event data is not acquired to the internal memory even if the trigger condition is met.

- **Block display**
When the event data acquisition area is divided into multiple blocks, the block usage is displayed.
White blocks: Blocks with no data.
Green blocks: Block containing data that was acquired to the internal memory after starting the current acquisition of event data.
Gray blocks: Blocks containing previous data.

7. Icon indicating the external storage medium status

If F and G are displayed alternately, the external storage medium is being accessed. If the icon is not displayed, this indicates that an external storage medium is not inserted in the drive. Other indications are as follows.

E: The operation cover on the front panel is open.

G: External storage medium waiting (not being accessed).

H: The green level inside the icon indicates the amount of the external storage medium used. If the remaining amount falls to 10% or less, the color changes to red.

Note

- The CX2000 detects whether an external storage medium is inserted in the drive when the operation cover is closed.
 - To prevent adverse effects from dust, use the CX2000 with the door closed.
-

8. Computation icon (only on models with the computation option)

No computation mark is displayed: No computation option or computation is stopped.

White computation icon: Computation in progress.

Yellow computation icon: Computation dropout occurred.

Note

Computation dropout occurs when the computation process cannot be completed within the scan interval. Press "FUNC > [Math ACK] soft key" to set the icon back to a white computation icon. If computation dropouts occur, increase the scan interval or reduce the number of computation channels that are turned on.

9. Key lock icon

Key icon: Key locked

No indication: No key lock

10. E-mail transmission function icon

Displayed when the e-mail transmission function (see the *DAQSTATION CX1000/CX2000 Communication Interface User's Manual*) is enabled.

11. Alarm icon

Displayed when any one of the alarms is occurring.

- **Data Display Section**

The control operation display shows the PV input values, SPs, and OUT for monitoring the control status, tuning information, and so on. The measurement operation display shows the trend display, digital display, and bar graph display of the measured and computed data as well as alarm, message, and file information. For details on the displayed contents, see the following pages.

Setting Groups

The control monitoring data and measured/computed data on the operation display are shown in groups. Therefore, control loops and measurement channels must be assigned to groups.

Setting Control Groups (for the Control Function)

Up to 6 loops can be assigned to each group. There are eight groups in which external loops (loops of externally connected controllers) can also be registered. You can assign a group name for each group.

Setting Measurement Groups (for the Measurement Function)

Measurement channels or computation channels are assigned. Up to 10 groups can be registered. The groups are common to the trend, digital, and bar graph displays.

On the trend, digital, and bar graph displays, the displayed groups can be automatically switched at "5 s," "10 s," "20 s," "30 s," or "1 min" intervals.

For trend display, the waveform of all applicable channels can be displayed on a single display rather than in groups.

Displaying Tags

For identifying the control loops and channels, tags (tag comments can also be assigned to control loops) can be displayed in place of numbers.

Control Operation Display > Control Group Display

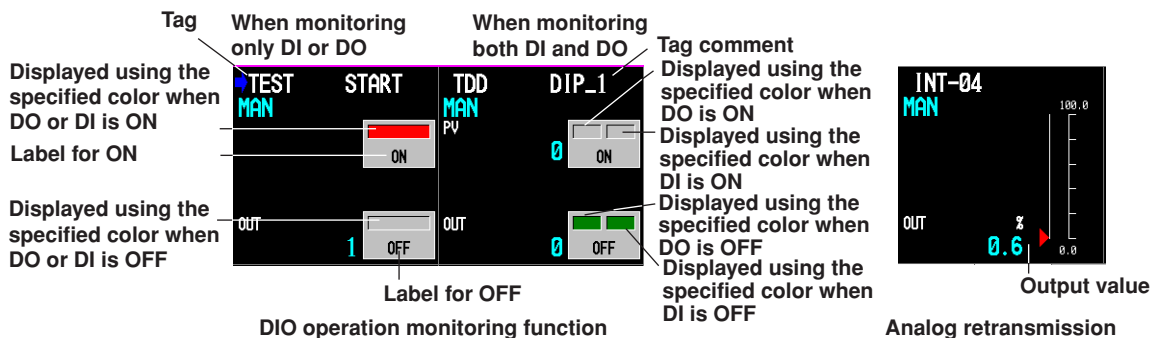
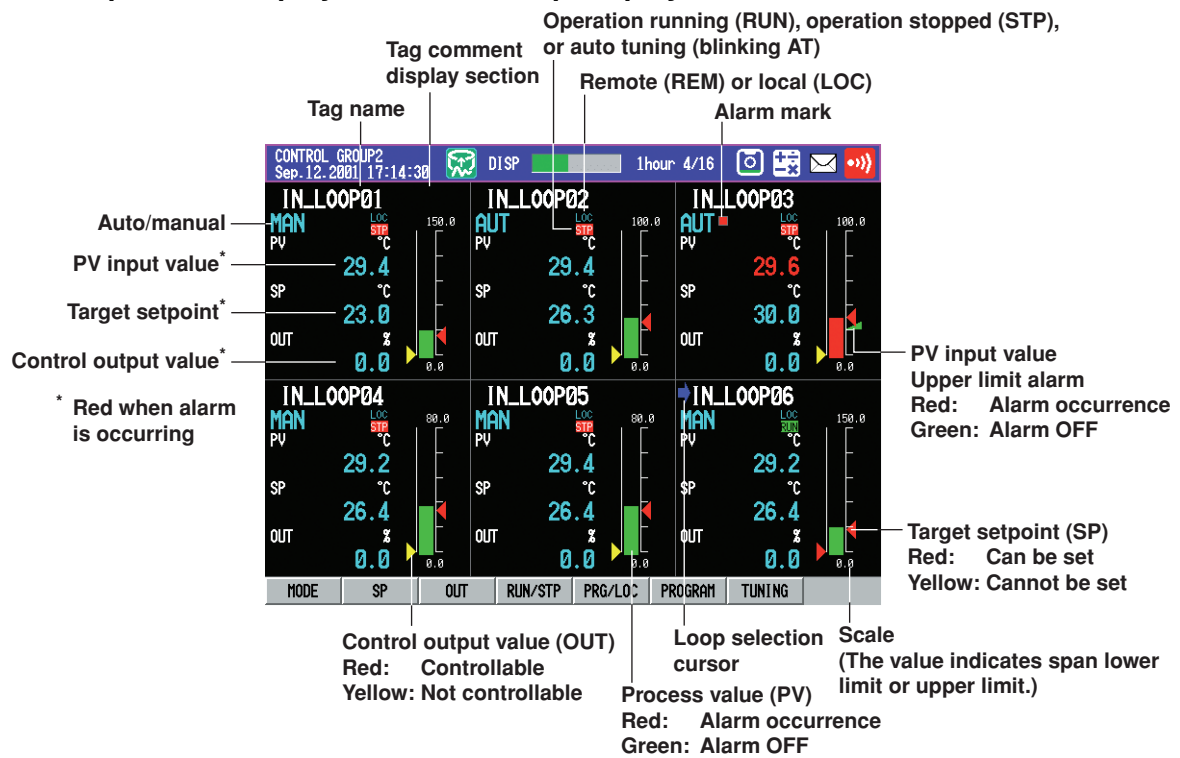

Control Operation Display > Tuning Display

Control parameter setup display section

Control status indication section (similar to the display on the faceplate control group display)

Setup display
 AT: PID number being auto tuned
 SP No.: Current target setpoint number
 PID No.: Current PID number
 Group No.: PID number of the tuning parameter to be manipulated

Trend waveform display of PV (green), SP (red), and OUT (yellow)

Time

Control > Overview Display

Loop selection cursor

Tag name

Remote (REM) or local (LOC)
 Red indication when alarm is occurring

Run (RUN)/ Stop (STP)/ auto tuning (blinking AT)

Auto/manual

PV input value

Target setpoint

Control output value

DIO operation monitoring function

When monitoring only DI or DO

When monitoring both DI and DO

Label for ON

Label for OFF

Tag

Tag comment

Output value

Analog retransmission

Displayed using the specified color when DO or DI is ON

Displayed using the specified color when DO or DI is OFF

Displayed using the specified color when DO is ON

Displayed using the specified color when DI is OFF

Displayed using the specified color when DO is OFF

Control Operation Display > DI/DO Status Display

Contact ON/OFF (red: ON, green: OFF) Contact number (DI: input, DO: output)



Note

Contact displays with numbers "DOXXX" indicate the alarm output status, not the ON/OFF status of the output. For example, if the energize/de-energize setting of an alarm output relay is set to "de-energize," the indication turns red when an alarm occurs to indicate that it is de-energized.

Control Operation Display > Internal Switch Status Display (Style Number S3 or later)

ON/OFF (red: ON, green: OFF)

Internal switch number



Control Operation Display > Control Action Summary Display

Number of the control operation information displayed on the bottom line
 Number of control operation information in the internal memory
 Tag name + tag comment or pattern name (when program operating)
 Pattern name while operation mode is RUN, RESET, HOLD ON/OFF, or WAIT ON/OFF
 Operation status
 Date and time of occurrence

(020/021) Name	Status	Time
IN_LOOP06	STOP	Sep. 12. 2001 15:02:26
IN_LOOP05	STOP	Sep. 12. 2001 15:02:22
IN_LOOP04	STOP	Sep. 12. 2001 15:02:18
IN_LOOP03	STOP	Sep. 12. 2001 15:02:06
IN_LOOP02	STOP	Sep. 12. 2001 15:02:03
IN_LOOP01	STOP	Sep. 12. 2001 15:01:52
IN_LOOP01	RUN	Sep. 12. 2001 15:01:44
IN_LOOP02	RUN	Sep. 12. 2001 15:01:39
IN_LOOP03	RUN	Sep. 12. 2001 15:01:35
IN_LOOP04	RUN	Sep. 12. 2001 15:01:31
IN_LOOP05	RUN	Sep. 12. 2001 15:01:22
IN_LOOP06	RUN	Sep. 12. 2001 15:01:13
IN_LOOP06	MAN	Sep. 12. 2001 15:01:03
IN_LOOP05	MAN	Sep. 12. 2001 15:00:57
IN_LOOP04	MAN	Sep. 12. 2001 15:00:53
IN_LOOP03	MAN	Sep. 12. 2001 15:00:48
IN_LOOP02	MAN	Sep. 12. 2001 15:00:43
TIC001	AUTO	Sep. 12. 2001 13:55:51
TIC001	MAN	Sep. 12. 2001 13:55:48
IN_LOOP02	STOP	Sep. 12. 2001 13:53:23

Cursor
 (Select a control operation using the cursor and select [INFORMATION] > [JUMP TO HISTORY] from the display selection menu to display the historical trend of the data containing the selected control operation)

Note

- The status indicates "****," if an error is occurring on an external loop using the optional Green series communication function.
- With style number S2 or earlier, the name is displayed as Tag name + tag comment or program while the program is running.

Control Operation Display > Program Event Summary Display (Only on Models with the Program Control Option)

Number of the event information displayed on the bottom line
 Number of the event information in the internal memory
 Event ON/OFF status (red: ON, green: OFF)
 Event kind
 Time event: TIME + 2-digit event number + pattern name
 PVE + 2-digit event number + tag name + event type or
 PVE + 2-digit event number + tag name
 Event ON time
 Event OFF time

(008/008) Type	Event IN Time	Event OUT Time
PVE03:INT-01.DVO	Apr. 04. 2002 09:11:10	
PVE01:INT-01.PVH	Apr. 04. 2002 09:11:10	
TIME02	Apr. 04. 2002 09:07:56	Apr. 04. 2002 09:09:17
TIME01	Apr. 04. 2002 09:07:56	Apr. 04. 2002 09:08:26
PVE03:INT-01.DVO	Apr. 04. 2002 09:07:26	Apr. 04. 2002 09:09:17

Cursor
 (Select an event using the cursor and select [INFORMATION] > [JUMP TO HISTORY] from the display selection menu to display the historical trend of the data containing the selected

Note

- For a description of the program control display and program selection display, see section 6.4, "Operations on the Program Selection Display and Program Control Display."
- With style number S3 or later, you can select to display PV event types as PVE + 2-digit event number + tag name + event type, or PVE + 2-digit event number + pattern name.

Control Operation Display > Trend Display

Displayed Information and Display Direction

In addition to the waveforms of measured/computed data, PVs, SPs, and OUT of internal/external control loops are also assigned to channels and displayed. The display direction of the waveform can be set to horizontal or vertical as show in the following figure. Numeric values can be displayed along with waveforms.

Note

For a description of the assignment of internal control channels (internal loop channels) and external control channels (external loop channels), see channel assignment explanation on *page 1-89*.

Trend (Horizontal) Display

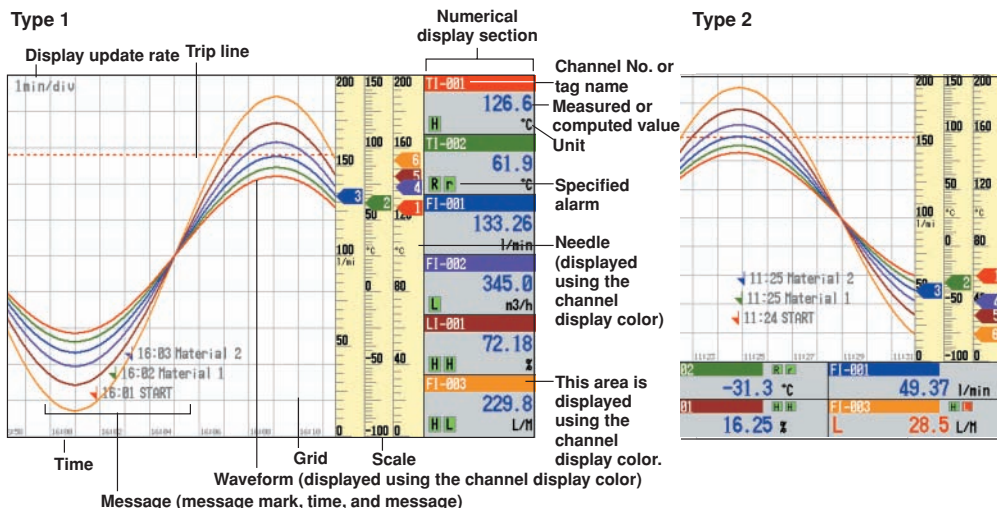

Trend (Vertical) Display

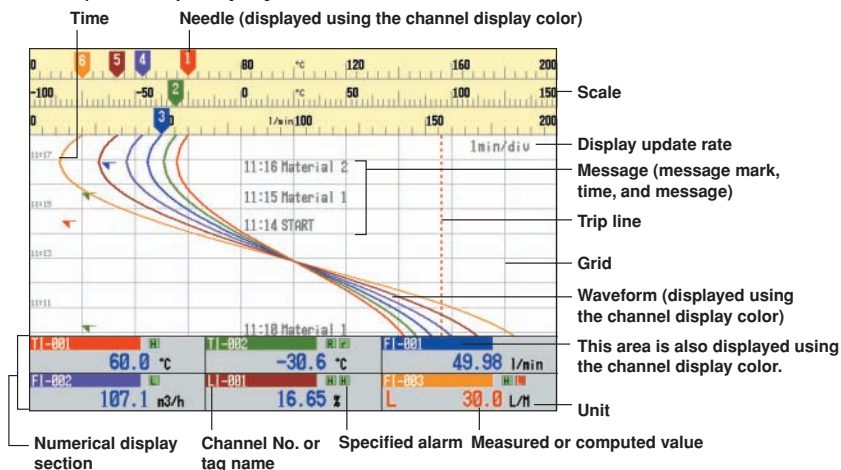

Displayed Information	Description
Message	Messages specified by the user can be displayed at arbitrary points in time. For example, by displaying a message when a certain operation is carried out, the point at which the operation is carried out can be seen visually. Displayed messages are saved.
Trip line	You can display a line to indicate a particular value of interest (trip line) for each group. You can select the thickness of the displayed line from three types: 1, 2, or 3 dots. Up to four trip lines can be displayed on a single group.
Scale	A scale appropriate for the measured item can be displayed for each channel. The number of divisions of the display scale created by the main scale marks can be set to a value in the range 4 to 12 divisions (also applies to the bar graph display). Medium and small scale marks are displayed in between the main scale marks. You can select whether or not to display the scale for each channel and the display position.

1.16 Display Function

Updating the Waveform and Updating the Numerical Display

One division on the CX2000 consists of 30 dots along the time axis on the LCD. The displayed waveform is updated at an interval corresponding to one dot. This interval is determined by the time corresponding to one division (referred to as the display update rate). The relationship between the display update rate and the speed of movement of waveforms is as follows. Measured/computed values of the numerical display are updated every second (every 2 s if the scan interval is set to 2 s on the).

Display Update Rate (/div)	1 min	2 min	5 min	10 min	20 min	30 min	1 h	2 h	4 h	10 h
Speed of Movement of Waveforms (approximate value, mm/h)	594	297	119	59	30	20	10	5	2.5	1.0

Note

The speed of movement of the trend display along the time axis is derived from the following equation given the dot pitch of the LCD (0.33 mm).

The speed of movement of the trend display along the time axis = $30 \text{ (dots)} \times 0.33 \text{ (mm)} \times 60 \text{ (min)/display update rate (min)}$

Display Format of Waveforms

The data shown on the display consists of maximum and minimum values of the data that is sampled at the scan interval, within the time period corresponding to one dot.

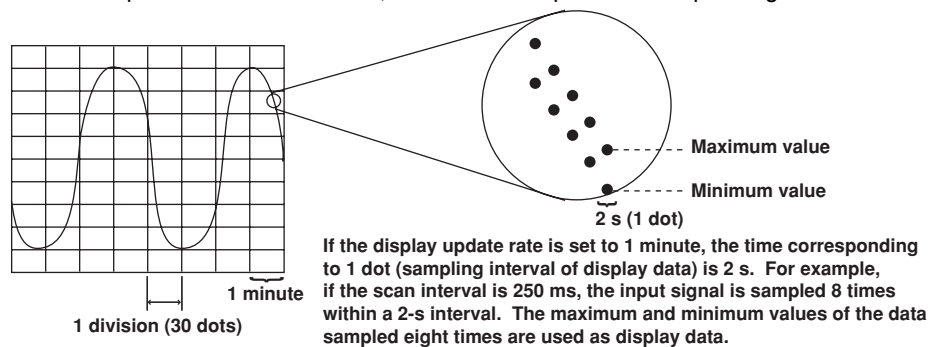

The time period corresponding to one dot is called “the sampling interval of displayed data.” The sampling interval of displayed data is determined by the display update interval. The relationship between the display update rate and the sampling interval of displayed data is as follows:

Display Update Rate (/div)	1 min	2 min	5 min	10 min	20 min	30 min	1 h	2 h	4 h	10 h
Sampling interval of displayed data (s)	2	4	10	20	40	60	120	240	480	1200

Zone Display

The waveform display range is called a zone. You can display channels by setting a zone for each channel. Displaying the waveforms in separate zones facilitates reading of the waveform. In the example in the figure, channel 1 is displayed in the 0 to 30% zone, channel 1 in the 30 to 60% zone, and channel 3 in the 60 to 100% zone.

When zone display is not used

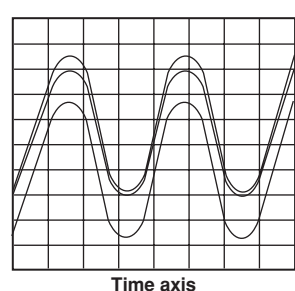

When zone display is used

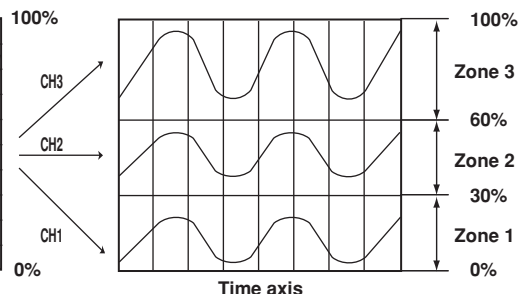

Partial Expanded Display

This function compresses a section of the waveform display range and expands the rest of the section. In this function, you specify the destination position (the new boundary position) where a single value (boundary point) in the display range is moved. In the example in the figure, 0 V (boundary value) is moved to the 30% position of the display range (new boundary position). The 30% below the boundary corresponds to “-6 V to 0 V” and 70% above the boundary corresponds to “0 V to 6 V.”

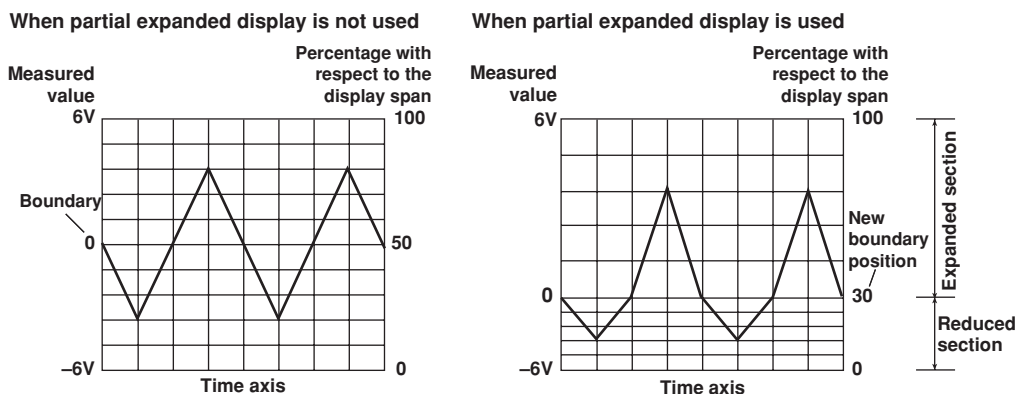

Waveform color and line thickness

The waveform color can be set or changed for each channel. The waveform color and the bar color in the bar graph display are the same.

You can select the thickness of the waveform line from 1 to 3 dots. The thickness of the line cannot be set separately for each channel.

Control Operation Display > Digital Display

Displays the measured, computed, and control data numerically using large numbers.

TI-001 65.1 H °C	FI-002 125.4 L m ³ /h	Channel No. or tag name
TI-002 -23.4 R R °C	LI-001 20.94 H H %	Measured or computed value
FI-001 56.42 l/min	FI-003 45.4 H L L/M	Unit
		Specified alarm

Updating of the Numerical Display

Measured/computed values are updated every second (every 2 s if the scan interval is set to 2 s).

Control Operation Display > Bar Graph Display

Displays the measured, computed, and control data using bar graphs.

Bar Graph (Horizontal) Display

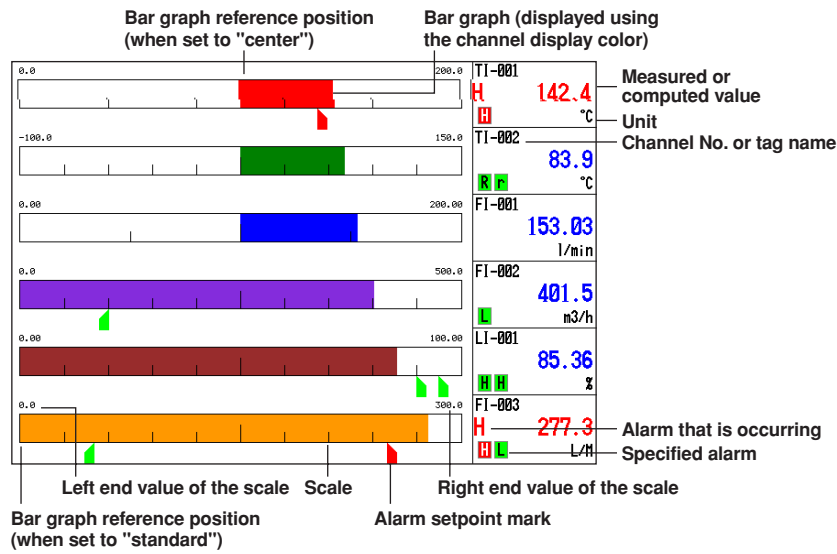

Bar Graph (Vertical) Display

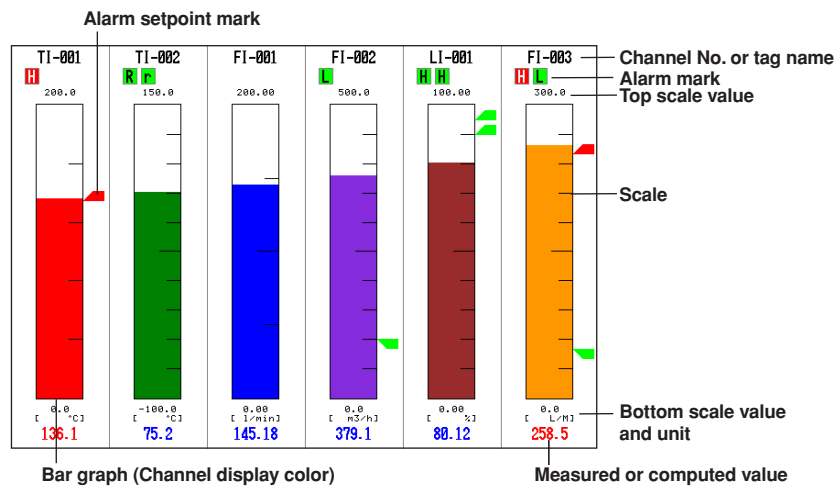

Updating of the Bar Graph and Numerical Displays

Measured/computed values and bar graphs are updated every second (every 2 s if the scan interval is set to 2 s).

Displayed Information

The following items can be displayed:

Function	Description
Display direction	The bar graph can be displayed vertically or horizontally.
Reference position	When the bar graph is displayed horizontally, the starting point of the bar (reference position) can be set to standard (Left or right end of the scale, whichever the value is smaller) or the center.
Display color	The displayed color of bar graphs can be specified for each channel. The display color is common to the trend display color.
Scale display	Main scale marks are displayed for each channel. You can select the number of divisions created by the main scale marks from 4 to 12. This is common with the number of scale divisions of the trend display.

Control Operation Display > Overview Display

A list of measured/computed values and alarm conditions of all measurement/computation channels is displayed. You can move the cursor to select a channel and display the trend or bar graph of the group containing the selected channel. For the procedure in displaying the overview display, see section 8.6.

The type of alarm that is occurring
Channel selection cursor

Measured or computed value

Area of channels on which an alarm is occurring is indicated in red
Area of channels on which an alarm is not occurring is indicated in green

Channel No. or tag name

TIC-001 101.40	CIR-011 83.3	TIR-021 H 285.1	MATH-031 101.40	MATH-041 83.30	MATH-051 285.10
TIC-002 76.1	CIR-012 82.9	TIR-022 20.3	MATH-032 76.10	MATH-042 82.90	MATH-052 20.30
TIC-003 L 84.6	CIR-013 165.3	TIR-023 80.8	MATH-033 84.60	MATH-043 H 165.30	MATH-053 80.80
PIC-004 405.7	VIR-014 H 123.4	TIC-024 120.6	MATH-034 405.70	MATH-044 123.40	MATH-054 H 120.60
PIC-005 125.1	VIR-015 23.1	TIC-025 32.2	MATH-035 H 125.10	MATH-045 23.10	MATH-055 32.20
PIC-006 75.0	VIR-016 102.3	TIC-026 56.0	MATH-036 75.00	MATH-046 102.30	MATH-056 56.00
FIC-007 H 148.1	WIR-017 111.1	PIC-027 H 239.0	MATH-037 148.10	MATH-047 H 111.10	MATH-057 239.00
FIC-008 39.4	WIR-018 81.2	PIC-028 139.7	MATH-038 39.40	MATH-048 H 81.20	MATH-058 139.70
FIC-009 H 363.6	WIR-019 242.9	PIC-029 79.1	MATH-039 363.60	MATH-049 242.90	MATH-059 79.10
FIC-010 432.4	WIR-020 20.9	PIC-030 31.5	MATH-040 432.40	MATH-050 20.90	MATH-060 31.50

Update Rate of the Numerical Display

Measured/computed values are updated every second (every 2 s if the scan interval is set to 2 s).

Control/Masurement Common Operation Display > Alarm Summary

Lists the newest control alarms and measurement alarms. By scrolling the display using the arrow keys, up to 120 incidents can be displayed. By selecting an alarm from the list using up and down arrow keys, the historical trend of the display data or event data containing the alarm can be recalled. For a description on the historical trend display, see the section "Measurement Operation Display > Historical Trend".

Number of the alarm information displayed on the bottom line

Number of the alarm information in the internal memory (120 max.)

Control loop name (tag name + tag comment)/channel number (or tag name)

Alarm number (1, 2, 3, 4)

Alarm type
Control alarm: PVH, PVL, SPH, SPL, OTH, OTL, DVH, DVL, DVO, DVI, ETC (see Note below)
Measurement alarm: H, L, h, l, R, r, T, t

Date and time when the alarm occurred

Date and time when the alarm was released

(020/122) Name Type Alarm IN Time Alarm OUT Time

Alarm selection cursor* →

Alarm status indication mark

●	FI-003	2L	Aug. 02. 2001 16:15:28	
●	TI-001	1H	Aug. 02. 2001 16:07:24	Aug. 02. 2001 16:10:52
●	FI-003	1H	Aug. 02. 2001 16:07:15	Aug. 02. 2001 16:10:59
●	FI-002	1L	Aug. 02. 2001 16:00:26	Aug. 02. 2001 16:01:40
●	FI-003	2L	Aug. 02. 2001 15:59:14	Aug. 02. 2001 16:02:45
●	TI-001	1H	Aug. 02. 2001 15:51:10	Aug. 02. 2001 15:54:38

* Select a alarm using the cursor and select [INFORMATION] > [JUMP TO HISTORY] on the display selection menu to display the data historical trend containing the selected alarm information.

Note

- You can also display only the control alarms (see page 8-1).
- Alarm type indicates [ETC], if the alarm is an external loop and the alarm is of a type other than the control alarms that you can specify on the CX2000.

Control Operation Display > Message Summary

- A list of written messages and the time the messages were written is displayed.
- Up to 120 sets of message information can be stored to the internal memory. When the number of message information exceeds 120, the information is overwritten from the oldest information.
 - By scrolling the screen using up and down arrow keys, the message information in the internal memory can be displayed.
 - By selecting a message from the list using up and down arrow keys, the historical trend of the display data or event data containing the message can be recalled. For a description on the historical trend display, see “Control Operation Display > Historical Trend” in this section.

Number of the message displayed on the bottom line
 Number of messages in the internal memory
 Message string
 Message string Date/time Name of the user who wrote the message when message as written the message

(004/004) Message	Time	User Name
→ TEST 4	Jan. 08. 2000 21:52:04	user1
TEST 3	Jan. 08. 2000 21:51:53	user1
TEST 2	Jan. 08. 2000 21:51:16	user1
TEST 1	Jan. 08. 2000 21:49:02	

Cursor
 (Select a message using the cursor and select [INFORMATION] > [JUMP TO HISTORY] on the display selection menu to display the data historical trend containing the selected message.)

Control Operation Display > Memory Summary

- The information pertaining to the display data and event data in the internal memory is displayed.
- By selecting the display data or event data using the arrow keys, the historical trend display can be recalled. For a description on the historical trend display, see “Control Operation Display > Historical Trend” in this section.
 - The number of manual sampled data, TLOG data (/M1 option), and report data (/M1 option) residing in the internal memory are displayed.
 - For models that have the alarm output relays (option), the ON/OFF status of the relays are also listed.

Number of data points in the internal memory/maximum number of data points that can be acquired in the internal memory
 Date/time when the newest data was acquired

M. SAMPLE DATA (01/50) : Jan. 09. 2000 13:42:33
 TLOG DATA (000/400) :
 REPORT DATA (00/40) :
 SAMPLE DATA : ● DISPLAY DATA ○ EVENT DATA

Start Time	End Time	Data	Factor
→ Jan. 09. 2000 13:41:38	Jan. 09. 2000 13:43:04	44	Sampling
Jan. 08. 2000 21:51:48	Jan. 08. 2000 21:59:34	234	Stop
Jan. 08. 2000 21:51:10	Jan. 08. 2000 21:51:26	9	Stop

Date/time when the data acquisition started
 Date/time when the data acquisition ended*
 Factor causing the end of data acquisition
 Sampling count

Cursor
 (Select the data using the cursor and select [INFORMATION] > [JUMP TO HISTORY] on the display selection menu to display the historical trend of the selected data.)

* On models with the optional /BT1 batch header, the batch number and lot number for each file can be displayed in place of the date and time the data acquisition ended.

Control Operation Display > Report Data (Optional Function)

Report data residing in the internal memory can be displayed. The report function is used to write the average, minimum, maximum, and sum at specified intervals for the specified channels. Reports can be made hourly, daily, weekly, or monthly.

Number of the report data being displayed
 Number of report data in the internal memory
 Type of report Start date/time Report date/time

Index: 7/13	Kind: Hourly	Start: Aug.07.2001 08:44:28	Timeup: Aug.07.2001 10:39:58
Channel	Unit	Sts	Ave Max Min Sum
TI-001	°C	-0P-	106.0 99999 54.0 2.505371E+05
TI-002	°C	-0P-	33.3 99999 -38.9 7.070073E+04
FI-001	l/min	-0P-	107.50 99999 42.51 2.540070E+05
FI-002	m ³ /h	-0P-	271.4 99999 85.7 6.415446E+05
LI-001	%	-0P-	55.00 99999 11.66 1.299320E+05
FI-003	L/H	-0P-	168.0 99999 12.0 3.370053E+05
CH07	V	-0P-	0.120 99999 -0.920 2.032095E+02
CH08	V	-0P-	0.120 99999 -0.920 2.032247E+02

Channel No. or Unit Report data status Average, maximum, minimum, and sum
 tag name

Control Operation Display > Four Screen Display

Up to four different display formats can be displayed at once. The formats that can be displayed are trend display, digital display, bar graph display, overview, alarm summary, message summary, memory summary, and control operation display (control group display, overview display, DI/DO status display, control operation summary, program event summary display). The data of different groups can be displayed in quadrants that are showing the trend display, digital display, or bar graph. The display condition of the 4 screen display can be registered (up to four configurations). The registered configuration can be recalled to the display. The initial setting is as follows:

Display Name	Displays Shown
MIX	Trend (group 1), digital (group 1), bar graph (group 1), and overview
ALL TREND	All trend displays (groups 1 through 4)
ALL DIGITAL	All digital displays (groups 1 through 4)
ALL BAR	All bar graph displays (groups 1 through 4)

Example of a "MIX" display

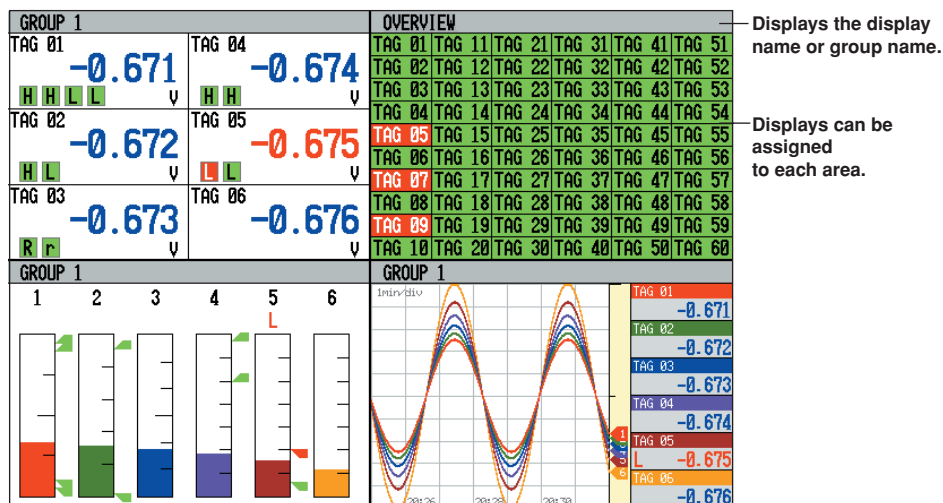

Press the left or right arrow key to display other "4 screen" displays.

Note

- The following information is not displayed on the 4 screen display.
- Measured/computed values , alarm type, and cursor of the overview
 - Scale of trends
 - Measured/computed values, upper and lower limit of span, and unit of bar graphs.
 - Cursors of alarm summary, message summary, and memory summary
 - The following displays that are assigned to the “4 screens” display channel numbers even if the setting is set to display tags.
 - Vertical trend display
 - Horizontal trend display with 7 or more channels assigned to the group
 - Bar graph display

Control Operation Display > Historical Trend Display

The waveform of the past display data and event data in the internal memory can be displayed. This function is called “Historical trend.”

Methods of Displaying the Historical Trend

The following four methods are available in displaying the historical trend.

- Display from the alarm summary.
- Display from the message summary.
- Display from the memory summary.
- Recall from the screen menu.

Information Displayed on the Historical Trend

Alarm information and scales are not displayed on the historical trend display.

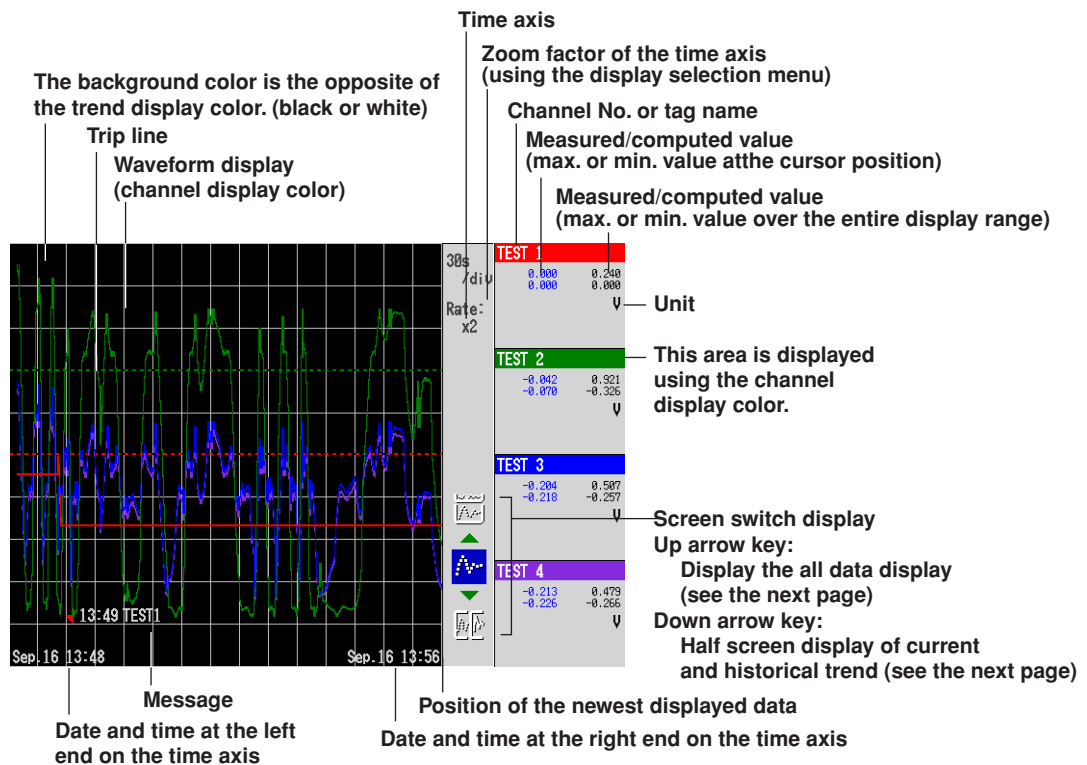

Operations on the Historical Trend Display

- The waveform can be scrolled along the time axis using the left and right arrow keys (for horizontal display) or up and down arrow keys (for vertical display).
- The time axis can be expanded or reduced using the display selection menu ([TREND HISTORY] > [ZOOM +] or [ZOOM -]).
- You can display all the data points on the historical trend display in a section of the screen (all data display). When you move the cursor (yellow line) using the left and right arrow keys (for horizontal display), the date and time of the acquisition of the data at the cursor position are displayed. By pressing the down arrow key (for horizontal display) after moving the cursor to return to the original display, you can change the display position within the entire data. In the display that appears, the data at the cursor position is shown at the right end of the display.

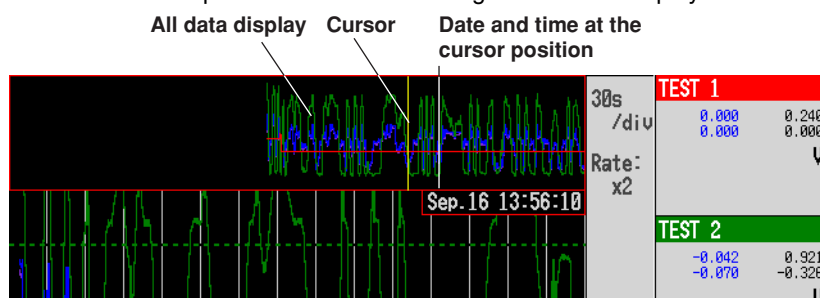

- You can display the information of the file displayed on the historical trend through the display selection menu operation ([Historical Trend] > [Memory Information ON]).

```
File Name (Data Kind): Memory (DISP)
Serial No.           : 12A725577
Start Time          : Jan.08.2000 15:40:16
Start User Name     : user1
End Time            : Jan.08.2000 15:40:32
End User Name       : user1
```

File name and data type
Serial No. of the instrument that sampled the data
Start/end time and user name (User name is displayed only when the key login function is used.)

When batch header is active

```
File Name (Data Kind): Memory (DISP)
Serial No.           : 12A338617
Application Name     : YOKOGAMA
Supervisor Name      : YOKOGAMA
Manager Name         : CX2000
Batch Name           : A100-0001
Start Time           : Jun.12.2003 20:55:10
End Time             : Jun.12.2003 22:03:36
```

Half Screen Display (Only When Displaying the Historical Trend of the Display Data)

Using up and down arrow keys, you can have the left half of the display (lower half if the trend display is vertical) show the historical data of the display data and the right half (upper half if the trend display is vertical) show the display data currently being measured.

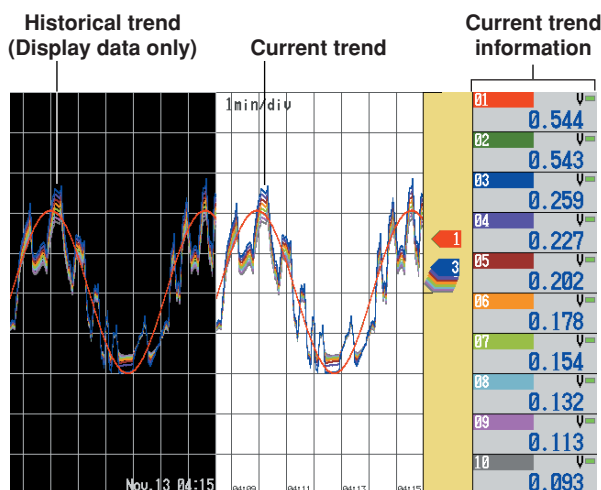

Control Operation Display > Alarm Display

The measurement alarm status is indicated using an alarm icon on the status display section (common with the control alarm) and the alarm indication on operation displays such as the trend display. The displayed pattern varies depending on the non-hold/hold mode of the alarm indication. In the explanation below, "Alarm ACK" refers to the alarm release operation.

Alarm Icon in the Status Display Section

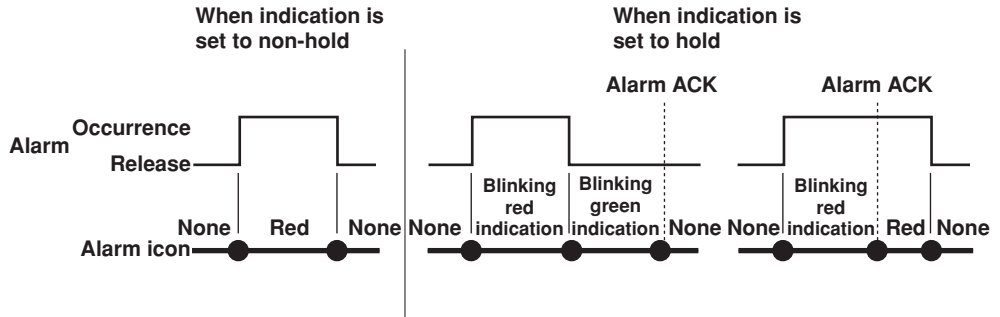

Alarm Indication on the Trend Display

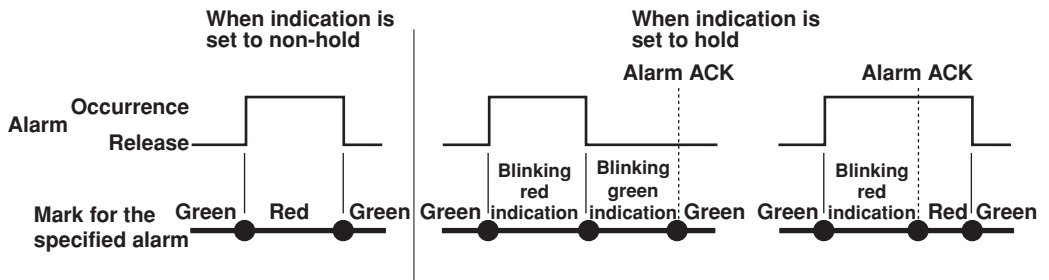
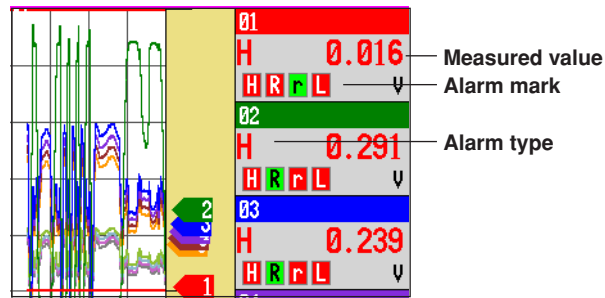

Alarm Indication on the Digital Display

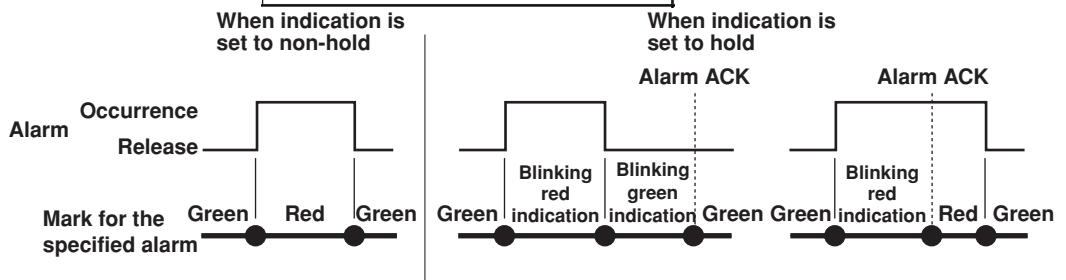

Alarm Indication on the Bar Graph Display

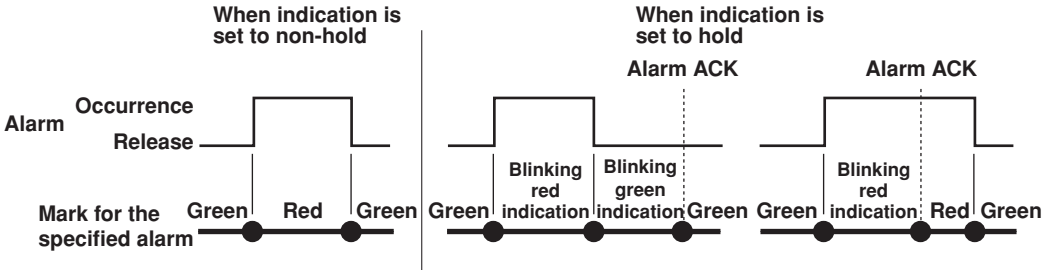
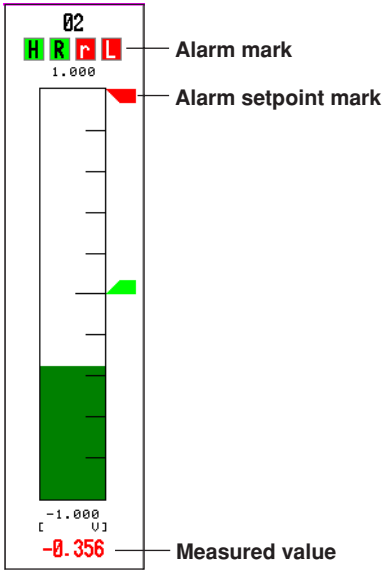

Alarm Indication on the Overview Display

Channel No. or tag name	Cursor	Alarm type	Measured value	Area of channels on which an alarm is occurring is indicated in red
TI-001		H	135.6 °C	TI-001
TI-002			74.4 °C	TI-002
TI-003				TI-003

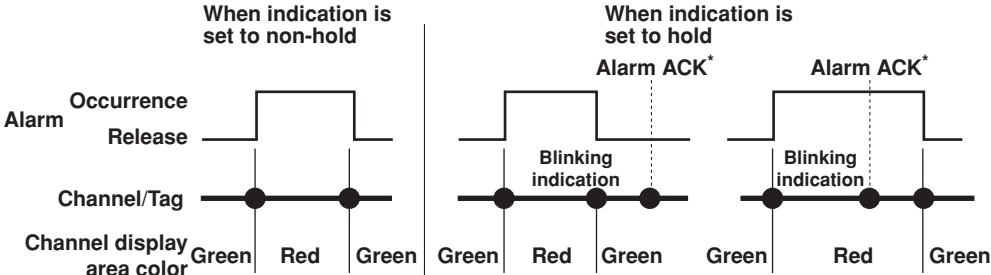

* When all the alarms occurring on the channel is acknowledged (alarm ACK).

Alarm Summary Display

A list of the most recent alarms can be displayed.

- Up to 120 sets of alarm information can be stored to the internal memory. When the number of alarm information exceeds 120, the information is overwritten from the oldest information.
- By scrolling the screen using arrow keys, the alarm information in the internal memory can be displayed.
- You can select arbitrary alarm information and show the historical trend of the display data or event data that contains the alarm information.

For the operating procedure, see *section 8.1*.

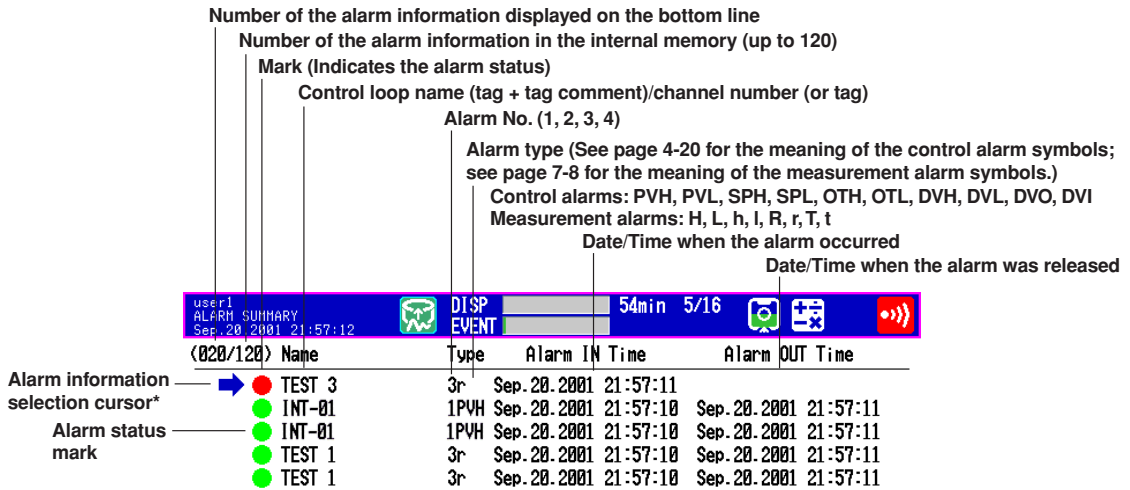

* Select the alarm information using the cursor and select [INFORMATION] > [JUMP TO HISTORY] on the display selection menu to display the historical trend containing the selected alarm information.)

Note

- You can also display only the control alarms (see page 8-1).
- Alarm type indicates [ETC], if the alarm is an external loop and the alarm is of a type other than the control alarms that you can specify on the CX2000.

Alarm Mark Indication

The mark indication varies depending on the hold/non-hold setting of alarm indication (see section 1.6) as follows.

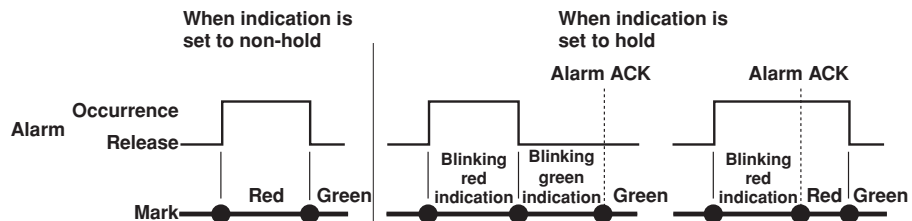

Setting the Display Conditions of the LCD

The following display conditions of the LCD can be configured.

Display Attribute	Setting
Background color of the operation display	The background color of the display can be set to white or black. The initial setting of the control operation display is [Black]; the initial setting of the measurement operation display is [White].
LCD brightness	The brightness of the LCD can be set between four levels. The initial setting is [3].
Backlight saver	The lifetime of the LCD backlight can be extended by automatically dimming the light when there is no key operation for a certain amount of time. The display returns to the original brightness with a key operation or an alarm occurrence. The initial setting is set so that the backlight saver is disabled.

1.17 Data Storage Function

Data Acquisition to the Internal Memory

Control Data

The following control related data can be acquired to the internal memory. Control related data includes the PV, SP, and OUT of external loops created through Green series communications in addition to those of internal loops.

Data Type	Data Content
Display data	Maximum/minimum values of PVs, SPs, and control outputs (OUT) for every interval of acquisition to the internal memory.
Event data	Instantaneous value of PV at every specified sampling interval.
Manual sampled data	Data in ASCII format containing the time and PV at the time of key operation or remote input.
Alarm summary data	Channel on which alarm is occurred, alarm type, and time of occurrence and release.
Event summary data	Loop number at which the time event or PV event occurred and the time of occurrence and release.
Operation mode summary data	Information of operation mode switching.

Internal control channel (internal loop channel) assignments

The data of 6 loops is assigned to channel numbers as follows.

Loop 1 PV: 101, Loop 1 SP: 102, Loop 1 OUT: 103

...

Loop 6 PV: 116, Loop 6 SP: 117, Loop 6 OUT: 118

External control channel (external loop channel) assignments

The data of 16 loops is assigned to channel numbers as follows.

External loop 1 PV: 201, External loop 1 SP: 202, External loop 1 OUT: 203

...

External loop 16 PV: 246, External loop 16 SP: 247, External loop 16 OUT: 248

Measurement Data

- Display data and event data

The measured/computed/control data can be written to two types of data, display data and event data, in the internal memory of the CX2000.

Display data

Data used to display waveforms on the CX2000 display. Display data consists of maximum and minimum values of the measured or computed data sampled at the scan interval within the time period corresponding to one dot on the time axis on the display. The display data that is saved can be likened to the conventional recording on the chart sheet and is useful for observations of long-term changes. The data is saved in binary format.

Event data

Event data consists of instantaneous values of the measured/computed/control data at specified sampling intervals. This is useful when you wish to observe the measured/computed/control data more in detail than display data. If the sampling interval is set to the same value as the scan interval, all the measured or computed data sampled at the scan interval can be acquired to the internal memory. The data is saved in binary format.

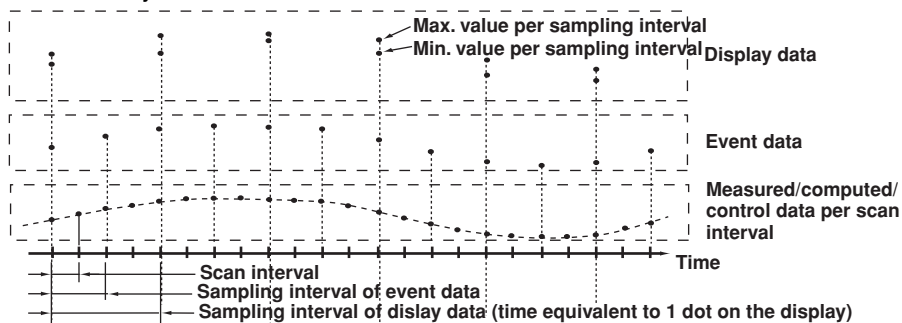

Internal memory size

The size of the internal memory for acquiring display data and event data is 1.2 MB. When the measured/computed/control data is saved using both display data and event data, 0.9 MB and 0.3 MB of memory is used for display data and event data, respectively.

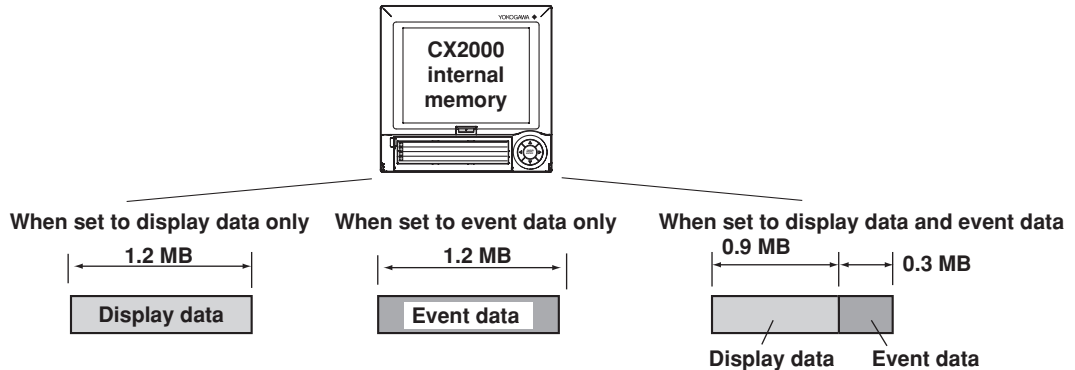

Data to be acquired and selecting the acquisition mode of event data

You can select “display data only,” “display data and event data,” or “even data only” for the items to be acquired (“Data type” in the settings). If “display data and event data” or “event data only” is selected, you can select the acquisition mode (“Mode” in the settings) from “Free,” “Trigger,” or “Rotate.” Refer to the following examples to make the appropriate selection for your application.

- Acquire only the display data at all times
Data to be acquired: Display data only
- Acquire display data in normal cases and acquire event data around the alarm occurrence when alarms occur
Data to be acquired: Display data and event data.
Acquisition mode: Trigger or rotate
- Acquire event data at all times
Data to be acquired: Event data only. Acquisition mode: Free
- Acquire event data only when alarms occur
Data to be acquired: Event data only. Acquisition mode: Trigger or rotate

Block segmentation during event data acquisition

In the acquisition of event data, the acquisition area in the internal memory can be divided into blocks (block segmentation). The acquisition operation varies depending on whether the acquisition area is divided into blocks for each mode. For detailed information, see “Acquisition Mode of Event Data” in appendix 1, “Supplementary Explanation of the Acquisition of Display Data/Event Data to the Internal Memory.” You can select the number of blocks from 2, 4, 8, and 16.

- **Manual sampled data**
Every time a given key operation is carried out, all measured/computed/control data (instantaneous values) at that point is acquired to the internal memory. However, this excludes measurement channels that are skipped and computation channels that are turned OFF.
- **TLOG data** (only on models with the computation function option)
All the measured/computed data (instantaneous data) of all channels can be acquired to the internal memory at the preset interval. However, this excludes measurement channels that are skipped and computation channels that are turned OFF.
- **Report data** (only on models with the computation function option)
The average, maximum, minimum, and sum can be computed for the specified channels at the preset interval, and the result can be acquired to the internal memory. You can select one hour (hourly report), one day (daily report), one hour/one day (hourly and daily), one day/one week (daily and weekly reports), or one day/one month (daily and monthly reports) for the interval.

Saving Data to the External Storage Medium

The data acquired to the internal memory can be saved to an external storage medium. The following two methods are available in saving the data.

Manual Save

The data in the internal memory is saved to the external storage medium, only when the external storage medium is inserted into the drive. You can specify whether to save the entire data in the memory or only the data that have not been saved to the external storage medium beforehand.

Auto Save

Have the external storage medium inserted in the drive at all times. Data storage to the external storage medium is done automatically.

Note

- If an external storage medium is not inserted when the data save operation is started during "auto save" mode, the unsaved data is saved the first time the specified interval elapses after an external storage medium is inserted.
- If the acquisition of the display data to the internal memory or acquisition of the event data to the internal memory in free mode is started, you can save the display data or event data at any time by operating the "[FUNC] key > soft key" even during auto save mode.

• Display data

The display data in the internal memory is closed as a single file at the specified interval or at the specified date and time and saved to the external storage medium in binary format.

Examples of data save operation to the external storage medium

Example 1

Auto save interval or data length: 1 day

Date and time when data is saved to the external storage medium: Not use

After starting at 13:10, data is saved every day at 13:10 to the external storage medium.



Example 2

Auto save interval or data length: 1 day

Date and time when data is saved to the external storage medium: 0 hour every day.

After starting at 13:10 on July 19th, data is saved at 0 hour on July 20th and then every day after and at 0 hour every day (the same time for both in this example).

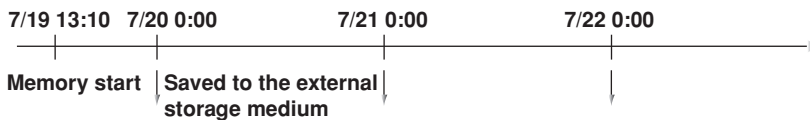

Example 3

Auto save interval or data length: 12 hours

Date and time when data is saved to the external storage medium: 0 hour every day.

After starting at 13:10 on July 19th, data is saved at 0 hour on July 20th and then every 12 hours after and at 0 hour every day (0 hour occurs at the same time as the 12 hour timing).

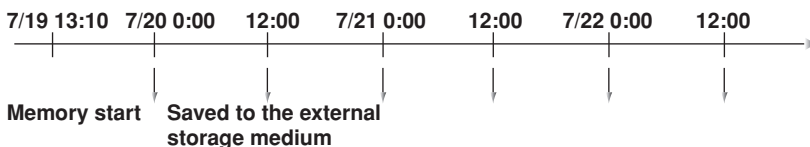

Example 4

Auto save interval or data length: 2 days

Date and time when data is saved to the external storage medium: 0 hour every day.

After starting at 13:10 on July 19th, data is saved at 0 hour on July 20th and then every 2 days after and at 0 hour every day (the 2-day timing occurs at the same time as 0 hour).

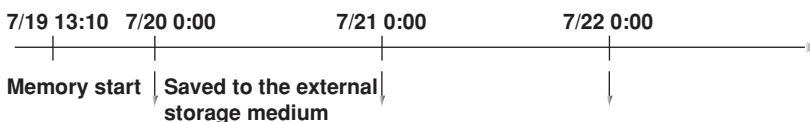

1.17 Data Storage Function

- **Event data**

- During the free mode

The event data in the internal memory is closed as a single file at the specified interval (data length) or at the specified date and time and saved to the external storage medium in binary format.

- During trigger or rotate mode

After acquiring the data to the internal memory over the specified period (data length), the event data in the internal memory is stored to the external storage medium in binary format.

The following figure shows the operation when the acquisition area in the internal memory is divided using the trigger mode.

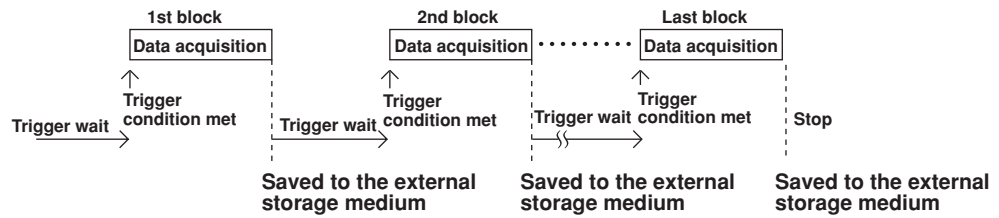

- **Manual sampled data**

The first time manual sample is executed, a manual sample data file is created on the external storage medium. Data is added to this file every time manual sample is executed. The data is saved in ASCII format.

Note

If an external storage medium is not inserted in the drive during auto save mode, the unsaved data is saved the first time manual sample is executed after an external storage medium is inserted.

- **TLOG data**

The first time TLOG data is created, a TLOG data file is created on the external storage medium. The data is appended to this file at the specified interval. If the number of TLOG data points saved exceed 400, a new file is created on the external storage medium. The data is saved in ASCII format.

- **Report data**

The first time report data is created, a report data file is created on the external storage medium. A file is created for each type of report such as daily and monthly. The data is appended to this file every time of report.

The report file is divided at the following times. The data is saved in ASCII format.

- For hourly reports
- When the report at 0 hour every day is created.
- When the number of data points in a single file reaches 25.
- For daily reports
- When the report on the 1st day of every month is created.
- When the number of data points in a single file reaches 32.

Other Types of Data That Can Be Stored

The following two types of data can be stored on the external storage medium.

- **Setup data**

The setup data can be saved to the external storage medium. The saved data can be loaded to change the CX2000 settings.

- **Image data of the display screen**

The image data of the display screen can be stored to the external storage medium in PNG format.

File Name

- The file name “(Sampling month, day, hour, minute of the first data).extension” of display data, event data, manual sample data, TLOG data, and report data is automatically assigned.
 - Display data file: Mddhhmma.CDS
 - Event data file: Mddhhmma.CEV
 - Manual sample data file: Mddhhmma.DMN
 - TLOG data file: Mddhhmma.DTG
 - Hourly data file: Mddhhmma.DHR
 - Daily data file: Mddhhmma.DDR
 - Weekly data file: Mddhhmma.DWR
 - Monthly data file: Mddhhmma.DMR
- M: Month (1-9, X (October), Y (November), Z (December), dd: day, hh: hour, mm: minute, a: the lowest digit of the year (0 to 9, except if another file with the same month, day, hour, and minute exist, in which case “a” to “z” are assigned in order).
- Setup data
Set the name using up to 8 characters through the save operation. A .pcl extension is automatically added when the data is saved.
 - Screen image data
The file name “(month, day, hour, minute when the save operation of the screen image data was executed+sequence number).png” is automatically assigned.
Mddhhmma.PNG
M: Month (1-9, X (October), Y (November), Z (December), dd: day, hh: hour, mm: minute, a: the lowest digit of the year (0 to 9, except if the screen image data is saved multiple times within a minute, in which case “a” to “z” are assigned in order from the second file)

Save Destination Directory

All the data excluding the setup data (display data, event data, manual sample data, TLOG data, report data (only on models with the computation function option), and screen image data) are saved to the specified directory. The setup data is saved to the root directory. The save destination directory varies depending on how the data is saved.

Auto save: Directory specified here.

Manual save: Directory with a sequence number added to the string specified here.

Save on the setting display: Directory with “A+sequence number” added to the string specified here (the sequence number increments every time the data is saved).

File Header of Display Data and Event Data

You can enter a header comment using up to 32 alphanumeric characters.

Saving Data via the Ethernet Network

The display data, event data, and report data, as described in “Data Acquisition to the Internal Memory,” can be automatically transferred to an FTP server via the Ethernet network for storage. Conversely, the CX2000 can function as an FTP server. The CX2000 can be accessed from a PC and the data in the external storage medium can be retrieved for storage. For a description on these functions, see the *CX2000 Communication Interface User's Manual (IM 04L31A01-17E)*.

1.18 Computation and Report Functions (Option)

Computation Function

You can perform computations by specifying a computing equation and display the results as computed values of a computation channel, on various displays such as the trend display, numerical display, and bar graph display. You can use data of measurement channels, the data of computation channels, the data of control channels, constants, etc. in the computing equation. Computed data can be saved similar to measured data of measurement channels. Computation is performed every scan interval.

Explanation of the computation function is also given in appendix 2, "Supplementary Explanation of the Computation Function" and appendix 3, "Meaning and Syntax of Computing Equations." Read them along with this section.

Channel Numbers Dedicated to Computations

The channel numbers dedicated to computations are 31 to 60 (30 channels).

Computation Types and the Order of Precedence of Computations

The following computations can be performed. The order of precedence of computations in descending order is functions (SQR, ABS, LOG, EXP, relational computation, logical computation, and statistic computation), exponentiation, logical negation, multiplication/division, addition/subtraction, greater/less relation, equal/not equal relation, logical product, logical sum/exclusive logical sum.

Type	Description
Four arithmetic operation	Addition (+), subtraction, multiplication (\times), and division ($/$)
**	Power. $y = X^n$
SQR	Square root
ABS	Absolute value
LOG	Common logarithm
EXP	Exponent. $y = e^x$
Relational computation	Determines $<$, \leq , $>$, \geq , $=$, or \neq of two elements and outputs "0" or "1."
Logical computation	Determines the AND (logical product), OR (logical sum), XOR (exclusive logical sum) of two elements, NOT (negation) of an element and outputs "0" or "1."
Statistical computation (TLOG)	Determines the average (AVE), maximum (MAX), minimum (MIN), sum (SUM), and maximum - minimum (P-P) at specified time intervals for the specified channels.
Rolling average	Determines the moving average of the computed results of the channels to which a computing equation has been assigned. The sampling interval and the number of samples can be specified for each channel. The maximum sampling interval is 1 hour; the maximum number of samples is 64.

Data That Can Be Used in Equations

Data	Description
Measured data	Measured value of a measurement channel or the control PV input.
Computed data	Computed value of a computation channel.
Constants	Set as constants K01 to K30 in the computation function.
Communication input data	Values set using the communication function and written as C01 to C30 (see the <i>DAQSTATION CX1000/CX2000 Communication Interface User's Manual</i>).
Conditions of the Remote Control Terminals	Input signal (0 or 1) of the remote control function, written as D01 to D08.

Handing of the Unit in Computations

The unit corresponding to the measured/computed data in the equation is not compensated. In computations, measured and computed data are handled as values without units. For example, if the measured data from channel 01 is 20 mV and the measured data from channel 02 is 20 V, the computed result of $01 + 02$ is 40.

Displaying the Computed Data

The computed data that is assigned to computation channels can be displayed on various operation displays using trend waveforms, bar graphs, and numerical values just like measured data.

Alarms of Computed Data

Like measurement channels, up to four alarms can be assigned to each computation channel.

Acquisition of Computed Data to the Internal Memory

Like measurement channels, the display data or event data of computation channels can also be acquired to the internal memory and saved to an external storage medium. In addition, the instantaneous values and TLOG data of computation channels can be saved through manual sample operations.

Report Function

The report function is one of the functions of the computation function option (/M1). It is used to compute the average, maximum, minimum, and sum of each specified channel at the specified interval and writing the result to the internal memory.

Explanation of the report function is also given in appendix 4, "Additional Explanation of the Report Function." Read it along with this section.

Item	Description
Types of reports	Select from hourly reports only, daily reports only, hourly and daily reports, daily and weekly reports, and daily and monthly reports.
Number of channels per report	Up to 30 channels
Computed data	Average, maximum, minimum, and sum
Number of reports that can be acquired to the internal memory	Up to 40
Data format	ASCII format

The reports are created every hour on the hour for hourly reports, at the specified hour for daily reports (once a day), at the specified hour on the specified day for weekly reports (once a week), and at the specified hour on the hour on the specified date for monthly reports (once a week). For example, in the case of daily reports, the average, maximum, minimum, and sum over a day for the specified channels are computed at the specified time (on the hour), and the results are acquired to the internal memory. This constitutes one report data set.

Unit of Sum Computation

In the sum computation, data are summed over the scan interval. However, for flow values that have units /s, /min, /h, or /day a simple summation results in the actual value not matching the computed result, because the scan interval and the unit of the input values are different. In these cases, the unit of the data measured over the scan interval is converted to match the unit of the input values, and the computation is performed. For example, if the scan interval is 2 s, and the input value is 100 m³/min, a simple summation would add 100 every 2 s resulting in 3000 after one minute. However, if the sum unit is set to /min, then 2 s/60 s is multiplied every scan interval before the value is added giving a result that has an m³/min unit.

The following converting equations are used to compute the sum. The scan interval unit is in seconds.

Off: $\Sigma(\text{measured/computed data every scan interval})$

/s: $\Sigma(\text{measured/computed data every scan interval}) \times \text{scan interval}$

/min: $\Sigma(\text{measured/computed data every scan interval}) \times \text{scan interval}/60$

/h: $\Sigma(\text{measured/computed data every scan interval}) \times \text{scan interval}/3600$

/day: $\Sigma(\text{measured/computed data every scan interval}) \times \text{scan interval}/86400$

1.18 Computation and Report Functions (Option)

Operation during Power Failures

If a power disruption occurred while the report function was in progress, the report function will resume after the power is restored. The exact operation will vary depending on whether the power is restored before or after the scheduled time to create a report.

Time of Recovery	Port Operation
After the time to create the report	Report data is created immediately after power is restored. The measured/computed data up to the time of the power disruption is used. For the next scheduled report, data after the power recovery are used.
Before the time to create the report	After power is restored, report data are created at the time of the next normally scheduled report. The measured/computed data excluding the power disruption period is used.

Handling of Abnormal Data

Handling of the measured/computed data containing abnormal values is as follows.

Type of Abnormal Data	Report Data		
	Average Value	Maximum/Minimum Value	Sum Value
Positive over*	Not used	Used	Not used
Negative over*	Not used	Used	Not used
Error	Not used	Not used	Not used

* "Over range" for measurement channels or "computation overflow" for computation channels.

Status

If the data of a measurement or a computation channel enters any of the conditions listed below within the relevant time period (one hour for hourly reports and one day for daily reports, for example), status is output to the report.

Data Condition	Status
Common to measurement and computation channels Measurement error or computation error	E
For measurement channels Positive (+) over range	O
Negative (-) over range	O
When the input type is voltage, over range occurs when the measured value exceeds the measurable range of $\pm 5\%$. Suppose the measurement range is 2 V, and the measurable range is -2.000 to 2.000 V. If the measured value exceeds 2.200 V, positive over range results; if the measured value falls below -2.200 V, negative over range results. If the input type is TC (thermocouple) or RTD (resistance temperature detector), over range occurs when the measured value exceeds approximately $\pm 10^\circ\text{C}$ of the measurable range. Suppose the measurement range is R, and the measurable range is 0.0 to 1760.0 $^\circ\text{C}$. If the measured value exceeds 1770.0 $^\circ\text{C}$, positive over range results; if the measured value falls below -10.0 $^\circ\text{C}$, negative over range results.	
For computation channels Positive (+) computation overflow (when the value exceeds $3.4\text{E} + 38$)	O
Negative (-) computation overflow (when the value falls below $-3.4\text{E} + 38$)	O
Power failure/Time change	Status
When a power failure occurs	P
When the time is changed	C

Numerical Display

The range of displayed values of report data is from -9999999 to 99999999 excluding the decimal point. The decimal point position corresponds to the position of the decimal point of the upper and lower limit span or upper and lower limit scale (for scaling). However, special displays are used for cases given in the table below.

- Measurement channel

Item	Data Condition of Measurement Channels	Displayed Output
Average value	When all of the data are measurement errors or over range	(Blank)
Maximum/Minimum Value	<ul style="list-style-type: none"> • When all of the data are measurement errors • Positive (+) over range • Negative (-) over range 	(Blank) 99999 -99999
Sum	<ul style="list-style-type: none"> • When all of the data are measurement errors or over range • When the sum value exceeds $3.4E + 38$ • When the sum value is below $-3.4E + 38$ 	(Blank) 9.999999E+99 -9.999999E+99

- Computation channel

Item	Data Condition of Computation Channels	Displayed Output
Average value	When all of the data are computation errors or computation overflow	(Blank)
Maximum/Minimum value	<ul style="list-style-type: none"> • When all of the data are computation errors • When the maximum value exceeds 99999999 • When the minimum value is -99999999 <p>The decimal position that was specified when the span for the channel was specified applies to the maximum and minimum values. For example, if the span setting of the channel is "200.0," then "99999999" is output when the value exceeds "99999999.9" and "-99999999" is output when the value is below "-9999999.9."</p>	(Blank) 999999999 -999999999
Sum	<ul style="list-style-type: none"> • When all of the data are computation errors or computation overflow • When the sum value exceeds $3.4E + 38$ • When the sum value is below $-3.4E + 38$ 	(Blank) 9.999999E+99 -9.999999E+99

Displaying and Saving Report Data

The report data in the internal memory can be displayed on the LCD of the CX2000. In addition, the report data in the internal memory can be saved to an external storage medium. The figure below shows an example of an hourly report.

Number of the report data being displayed

Index: 7/13	Kind: Hourly	Start: Aug.07.2001 08:44:28	Timeup: Aug.07.2001 10:39:58	Number of report data in the internal memory		Date/time of the newest report
				Type of report	Start date/time	
Channel	Unit	Sta	Ave	Max	Min	Sum
TI-001	°C	-OP-	106.0	99999	54.0	2.506371E+05
TI-002	°C	-OP-	33.3	99999	-38.9	7.878073E+04
FI-001	l/min	-OP-	107.50	99999	42.51	2.540787E+05
FI-002	m ³ /h	-OP-	271.4	99999	85.7	6.415402E+05
LI-001	%	-OP-	55.00	99999	11.65	1.299320E+05
FI-003	L/H	-OP-	168.0	99999	12.0	3.970853E+05
CH07	V	-OP-	0.120	99999	-0.320	2.832063E+02
CH08	V	-OP-	0.120	99999	-0.320	2.833247E+02

Channel No. or Unit Report data status Average, maximum, minimum, and sum tag name

1.19 Equations for Control Computation (Style Number S3 or Later)

PV/SP Computation

When PV and program control function is OFF, you can set an equation for SP of the loops set to remote SP.

Computation Type

- Measurement computations other than TLOG computations
- CLOG

You can calculate the max value, min value, average, and the difference in the max and min values of data measured at the same time (max 10 channels). Measurement data and control input data can be used for this computation.

You can not set an equation inside the CLOG equation.

One CLOG only can be set within the PV/SP equation.

The target data designation is delimited with periods. You can use hyphens to express a continuous range of channels.

- Conditions

A different computation is performed depending on the computed results of the specified equation.

For [eq1?eq2:eq3], if the computed result of eq1 is other than 0, eq2 is computed, and if that result is 0, then eq3 is computed.

You can set a conditional expressions such as [eq1?[eq2-1?eq2-2:eq2-3]:[eq3-1?eq3-2:eq3-3]].

Equations may not be used simultaneously.

Data That Can Be Used in Equations

The data that can be used in equations is the same data that can be used for the measurement computation function, plus the following:

- Control input channel data (2 loop models: CI01-CI05, 4 to 6 loop models: CI01-CI10).
- Constants (however W01-W36, and the measurement constants K01-K36 cannot be used).
- Status of internal switches.
- The status of the control relays (DO001-DO206) and control expansion relays (RO001-RO012).

Logic Computation

The computed result is output to the DO or internal switch as a 0 or 1.

Computation Type

Computation Type	Operator
Logical operation	AND, OR, XOR, NOT
Relational operation	.GT., .LT., .GE., .LE., .EQ., .NE.
Conditional expressions	[eq1?eq2: eq3]

Data That Can Be Used in Equations

Same as for PV/SP computation.

Analog Retransmission

If the control mode is Analog Retransmission, you can set an equation for the control output.

The data that can be used for the equation and the computation is the same as for the PV/SP computation.

1.20 Other Functions

USER Key

One of the following actions can be assigned to the USER key. The key is initially assigned "Alarm ACK."

Actions That Can Be Assigned

Name of Action	Action
Trigger	Key trigger used to start acquiring event data to the internal memory (valid only when event data is specified to be acquired to the internal memory and the trigger used to start the acquisition is set to key trigger).
Alarm ACK	Clears alarm display/relay output (valid only when the operation of the alarm display or output relay is set to "hold").
Math	Starts/stops computation (only on models with the computation function (/M1)).
Math reset	Resets computed data (Resets the computed value to 0. Only when computation is stopped on models with the computation function option).
Manual sample	Acquires instantaneous values of all channels to the internal memory.
Messages 1 to 8	Displays message 1 to 8 on the trend display and stores the message to the internal memory.
Snapshot	Saves the screen image data to the external storage medium.

Key Lock

Key lock is a function used to prohibit key operations, removal of the Zip disk, and saving of the data to the external storage medium in manual save mode, soft key operations on the control operation display, and setup operation on the control setting display. You must enter a password to release the key lock.

Key Lock Item

The characters in the middle column are the characters of the soft key menu that are displayed on the control operation screen.

START	Free	MODE	Free	Control menu lock	
STOP	Free	REM/LOC	Free	Range	Free
MENU	Free	RUN/STOP	Free	Alarm	Free
USER	Free	SP	Free	Operation	Free
DISP/ENTER	Free	OUT	Free	PID parameter	
Alarm ACK	Free	AUTO TUNING	Free		Free
Math	Free	SP.No	Free	Control group	
Write memory	Free	TUNING	Free		Free
Message.Mail		RUN/RESET	Free	Linearizer	Free
Manual sample		HOLD	Free	Detail setting	
Media	Free	ADVANCE	Free		Free
		PATTERN.No	Free	Program	Free
				Control math	Free

Operation during Key Lock

All keys except those shown in the following table are disabled.

Key Lock Item	Operation When Key Lock Is Enabled
DISP/ENTER key	Switching of operation displays prohibited
External storage medium	
• During manual save mode	Saving of data when the external storage medium is inserted is prohibited. Zip disk removal prohibited on models with Zip drives.
• During auto save mode	Zip disk removal prohibited on models with Zip drives.
Control menu lock	Soft keys that are locked cannot be used on setting mode (control) menu.

Key Login/Logout

You can set the CX2000 so that only certain users can operate the instrument. User name, user ID, and password are used to identify a user. Up to 7 users can be registered.

Log Display

A list of phenomena that occurred can be displayed in the order of occurrence for the following types. The newest 200 incidents are stored for communication commands; the newest 50 incidents are stored for other items.

Error Message Log

<005/005> Time	No.	Message
Jan.12.2000 00:36:47	201	"Not enough free space on media."
Jan.12.2000 00:36:19	210	"Media has not been inserted."

Error code Error message
 Date/time when the error occurred

Key Login/Logout Log

Number of the log displayed on the bottom line/total number of logs

<011/011> Time	I/O	No.	User Name
Jan.12.2000 04:03:45	In	01	user1
Jan.12.2000 03:19:23	In	01	user1
Jan.12.2000 03:08:36	In	01	user1
Jan.12.2000 02:45:59	In	01	user1
Jan.12.2000 02:21:42	In	01	user1
Jan.12.2000 01:53:54	In	01	user1

n: Key login User name
 Out: Logout
 Date/time of key login/logout

Communication Command Log

Number of the log displayed on the bottom line/total number of logs
 Connection status indication of the Ethernet interface
 Illuminated (green): Connected electrically
 Not illuminated: Not connected electrically

<007/007> Time	ID	User Name	I/O	Message	Link
Jan.12.2000 18:52:23	1	user	<	<Logout>	
Jan.12.2000 18:52:23	1	user	>	CC 0	
Jan.12.2000 18:51:48	1	user	<	<259>	
Jan.12.2000 18:51:48	1	user	>	FD 0,001,010	
Jan.12.2000 18:51:41	1	user	<	E0	
Jan.12.2000 18:51:41	1	user	>	B0 0	
Jan.12.2000 18:51:37	1	user	<	<Login>	

Message (up to 20 characters)
 Input/output signal (>: input, <: output)
 Name of the user who accessed the CX2000
 Number identifying the connected user
 Date/time the CX2000 was accessed

File Transfer Log Using the FTP Client Function

Number of the log displayed on the bottom line/total number of logs

<005/005> Time	No.	Code	Flag	File Name
Jan.12.2000 01:50:22	282	HOSTNAME	S	10101500.DDS
Jan.12.2000 01:50:22	282	UNREACH	P	10101500.DDS
Jan.12.2000 01:49:32			P	10101490.DDS
Jan.12.2000 01:48:51			P	10101480.DDS
Jan.12.2000 01:48:27			P	DX_FTPC.TXT

File name (8 characters)
 FTP connection destination
 Error code (P: primary, S: secondary)
 Date/time when file was transferred

Web Operation Log

(004/004)	Time	Request	No.	Parameter
Jan. 07. 2001	01:19:12	Message	155	2:stop
Jan. 07. 2001	01:18:29	Message		1:start
Jan. 07. 2001	01:18:15	Key		UP
Jan. 07. 2001	01:17:58	Screen		DIGITAL GROUP=1

Operation information
 Error code (See chapter 12.)
 Operation type
 Date/time when the operation was carried out on the Web screen.

E-mail Transmission Log

(005/005)	Time	Type	No.	Recipient / Error
Jan. 07. 2001	01:00:24	Full	264	1+2 Some recipients' addresses are inv..
Jan. 07. 2001	01:00:01	Time	1	H.S
Jan. 07. 2001	01:00:00	Report	1	H.S
Jan. 07. 2001	00:59:53	Report	1	H.S
Jan. 06. 2001	01:02:21	Alarm	1	H.S

Recipient (recipient address, message)
 Recipient (1: recipient 1, 2: recipient 2)
 Error code (See chapter 12.)
 E-mail type
 Date/time of e-mail transmission

System Display

The total number of inputs on the CX2000, the size of the internal memory, the communication functions, the external storage drive, the options, and the MAC address, and the firmware version number can be displayed.

Number of measurement inputs (measurement channels)
 Number of computation channels
 Number of internal control loops
 ANALOG: 10 MATH: 30 LOOP: 2
 MEMORY: 1200000 Internal memory size
 OPTION:
 RS-422 Communication interface
 ETHERNET External storage medium
 FDD Program control
 PROGRAM LARGE Green series communications
 EXT LOOP Ladder communications
 LADDER
 OUTPUT TERMINAL:
 SLOT1 PID Existence of control output terminal blocks
 SLOT2 None
 SLOT3 None
 SLOT4 None Existence of the option terminal block and type
 PRODUCT:
 MAC address 00:00:64:81:35:81 MAC address
 Version 0.03 Graphic : B8700ZC 0.03
 Firmware version

Displayed Language

The displayed language can be set to English, Japanese, German, French or Chinese*.

* Can be selected on a CX of version 3.02 or later.

FAIL/Memory End Relay Output (/A4F option or /A4FR option)

FAIL Output

When a failure occurs in the CPU of the CX2000, a relay contact signal (1 signal) is output.

The relay is energized when the CPU is normal; it is de-energized when a CPU failure occurs (de-energized on failure). Therefore, relay output is carried out also when the power is turned OFF (including a power failure) (see figure below). You cannot change this behavior.

The following figure shows the operation of the FAIL output relay (de-energized type).

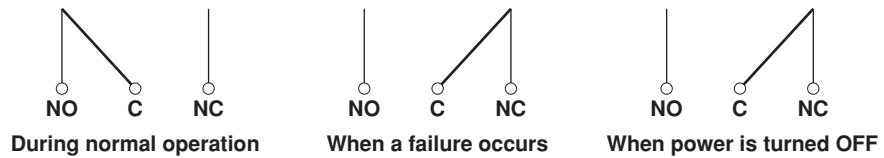

* NO, C, and NC are names of the relay output terminals.
 NO: Normally Opened, C: Common, NC: Normally Closed

Memory End Output

When the remaining free space in the internal memory or external storage medium becomes small, a relay contact signal (1 signal) is output. When a memory end is detected, the relay is energized (energized on memory end). You cannot change this so that it is de-energized on memory end. When memory end is output, save the data to an external storage medium (during manual save mode) or change the external storage medium (during auto save mode).

The memory end output operates as follows:

- During auto save mode
 - If an external storage medium is inserted in auto save mode, the relay is energized when the remaining free space on the external storage medium falls to 10%. (At this point, the icon indicating the status of the external storage medium in the status display section turns from green to red.)
- During manual save mode
 - If the type of data to be saved is display data only or display data and event data, the relay is energized when the remaining amount of time for acquiring the display data in the internal memory falls to the specified time.
 - If the type of data to be saved is event data only
 - If the CX2000 is in a mode in which data acquisition to the internal memory starts at the same time as the start of measurement, the relay is energized when the remaining amount of time for acquiring the event data falls to the specified time.
 - If the CX2000 is in a mode in which the data acquisition to the internal memory is started using a trigger such as an alarm occurrence, the relay is not energized (no memory end output).

The following figure shows the operation of the memory end output relay (energized on memory end).

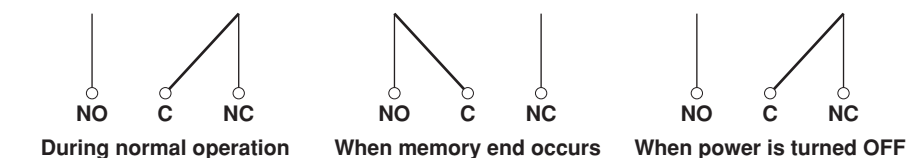

Measurement Remote Input (/A6R option or /A4FR option)

The actions shown in the table can be assigned to the contact signal or open collector signal that is input to the 8 remote input terminals [REMOTE] of the measurement alarm option terminal block.

Name of Action	Detection Method	Action
Start/Stop Trigger	Edge Trigger	Starts/stops data acquisition to the internal memory Trigger used to start acquiring event data to the internal memory (valid only when "event data" is specified to be acquired to the internal memory and the trigger used to start the acquisition is set to "external trigger").
Alarm ACK	Trigger	Clears alarm display/relay output (valid only when the operation of the alarm display or output relay is set to "hold").
Time adj Math	Trigger Edge	Adjusts the internal clock to the nearest hour. Starts/stops computation (only on models with the computation function (/M1)).
Math reset	Trigger	Resets computed data of measurement channels (Resets the computed value to 0. Only when computation is stopped on models with the computation function option).
Manual sample	Trigger	Acquires instantaneous values of all channels to the internal memory.
Load setup data 1 to 3	Trigger	Loads the setup data file saved to the external storage medium.
Messages 1 to 8	Trigger	Displays message 1 to 8 on the trend display and stores the message to the internal memory.
Snapshot	Trigger	Saves the screen image data to the external storage medium.

Note

- The actions above can also be registered to the contact inputs of the control output terminal block or the control DIO expansion terminal block.
- If the same action is performed using keys of the CX2000, communications, and contact input, the newest operation/input is valid regardless of the method. This is also true between control contact inputs and measurement remote inputs.

Method of Detecting the Remote Input Signal

The above actions are carried out on the rising or falling edge of the remote input signal (edge) or the ON signal lasting at least 250 ms (trigger). For contact inputs, the remote signal rises when the contact switches from "open to closed" and falls when the contact switches from "closed to open". For open collector signals, the remote signal rises when the collector signal (voltage level of the remote terminal) goes from "high to low" and falls when the collector signal goes "low to high."

Rising and falling edges



Trigger



VGA Output (/D5 option)

By using the RGB output, the CX2000 display can be displayed on a VGA monitor or multi-sync monitor that can display VGA. For the connection procedure, see *section 2.5*, "Connecting a Monitor to the VGA Output Terminal."

24 VDC power supply for transmitter (/TPS4 option)

Provides 24-VDC power supply for up to four two-wire system transmitters. The measured values of the transmitter correspond to a current signal of 4 to 20 mA on the same cable. The signal can be connected to the measurement input terminal of the CX2000 and displayed. For the connection procedure, see *section 2.6*, "Transmitter Power Supply Wiring."

Batch Header (/BT1 Option)

Batch header is used to include information such as batch numbers and lot numbers along with the data acquired to the internal memory. By including information such as batch numbers, lot numbers, and supervisor names along with the measured/control/computed data, you will be able to manage the stored data. By using the key login function in combination with this function, the operators that are allowed to store data on the CX can be restricted and identified.

Adding Batch Information to the Measured/Control/Computed Data

(Display Data and Event Data)

The following information can be added to the display data and event data acquired to the internal memory. For the setting procedure, see section 11.7.

The operator can change the batch number, lot number, and comment for each lot. In addition, the lot number can be automatically increased by one when one lot is complete.

- Serial number of the CX (the number written on the name plate of the CX).
- Application name (up to 16 characters).
- Supervisor name (up to 16 characters).
- Manager name (up to 16 characters).
- Batch name
- Batch number (up to 16 characters).
- Lot number (0 to 9999).
- Start information.
 - Start date and time and user name* (up to 16 characters).
 - * Only when the key login function is used.
- Stop information.
 - Stop date and time and user name* (up to 16 characters).
 - * Only when the key login function is used.
- Comment information.
 - Comment (up to 32 characters x 3 lines).
 - The date and time when comment was written.
 - User name* of the user who wrote comment (up to 16 characters).
 - * Only when the key login function is used.

Identifying Operators (Users) by using the Key Login Function

By using the key login function, the users that can log into the CX can be restricted and identified. When the batch header is activated, the security is enhanced in the following manner as compared with the standard key login function.

- User names that are already registered cannot be specified.
- The combinations of user IDs and passwords that are identical to those that have been registered by any user in the past cannot be specified.

Changing the Messages

When the optional batch function is installed, messages 1 through 3 can be changed in the operation mode. For the procedure related to changing the messages, see section 8.9.

Display

The following items are displayed:

- The batch number/lot number and date/time are alternately displayed in the status display section.
- When the STOP key is pressed, batch information is displayed in the stop confirmation screen.

Confirming the Stored Data

The display data and the event data in the internal memory or the external storage medium, can be displayed on the historical trend display.

- When the historical trend of the display data or event data in the internal memory or in the external storage medium is displayed, batch information can be shown in the memory information display.
- The batch number and lot number for each file can be displayed in place of the date and time of the file creation on the memory summary screen and on the screen used to select the display data and event data to be loaded from the external storage medium.

2.1 Handling Precautions

This section describes the precautions to be taken when using the CX2000 and the external storage medium. Make sure to read this section before using the CX2000.

Handling Precautions

- This instrument uses many plastic parts. When cleaning, wipe using a dry soft cloth. Do not use volatile chemicals since this might cause discoloring and deformation.
- Do not bring charged objects near the signal terminals. Doing so can lead to malfunction.
- Do not pour volatile agents on the LCD, panel keys, or other parts of the instrument nor leave them in contact with rubber or PVC products for an extended time. Doing so can lead to malfunction.
- Do not apply shock to the instrument.
- When not in use, make sure to turn OFF the power.
- If there are any symptoms of trouble such as smoke, strange odors, or strange sounds coming from the instrument, immediately turn OFF the power and disconnect power supply. Then, contact your nearest YOKOGAWA dealer or representative.

Handling Precautions for the External Storage Medium

- Use caution in the handling of the external storage medium as it is delicate.
- Write operations to floppy disks and Zip disks may fail in high-temperature or low-temperature environments. If you are using the CX2000 in a low-temperature environment (around 10 °C or less), use the CX2000 after the warm-up time (at least 30 minutes) has elapsed.
If you are using the CX2000 in a high-temperature environment (around 40 °C or more), it is recommended that the external storage medium be inserted into the drive when saving the data and be removed after the data storage operation is finished.
- If you are using a commercially available compact flash card on CX2000s in the ATA flash memory card drive, be careful of static electricity. The CX2000 may not operate properly if you touch the compact flash card that is inserted into the CX2000 when your body is charged with static electricity.
- Handling the CF Card and Adapter
Insert the CF card into the adapter as shown in the figure below. The card should remain in the adapter when removing it from the card slot on the CX2000.

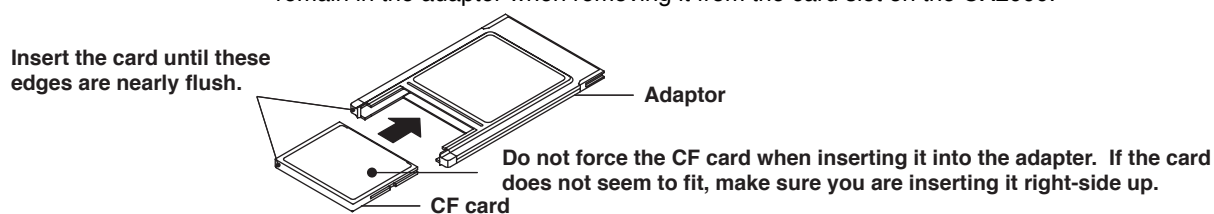

- For the general handling precautions of the external storage medium, see the instruction manual that came with that medium.

CAUTION

- If you turn ON/OFF the CX2000 while a Zip disk is inserted in the drive, the Zip drive may malfunction. When turning ON/OFF the CX2000, first remove the Zip disk from the drive.
- Do not eject the external storage medium while the access lamp is illuminated. This can damage the data.
- Do not operate the floppy disk drive or Zip drive in a place with vibrations or shock. The disk or drive may malfunction.

2.2 Installation

Installation Location

Install the CX indoors in a location that meets the following conditions. The environment of the installation location is described in *section 14.8, "General Specifications."*

- **Instrumentation Panel**
The CX2000 is designed to be installed in an instrumentation panel (panel mount type).
- **Well-Ventilated Location**
Install the instrument in a well-ventilated location to prevent the temperature inside the instrument from rising. For the panel cut dimensions when arranging multiple CX2000, see the *next page*. Also, when other instruments are arranged on the panel, allow adequate space between them.
- **Location Where Mechanical Vibration Is Small**
Select a location with low mechanical vibration for installation.
- **Horizontal Location**
When installing the CX2000, make sure it does not tilt to the left or right (0 to 30 degrees of backward tilt angle is allowed).

Note

- Condensation may occur if the instrument is moved to another place where the ambient temperature is higher, or if the temperature changes rapidly. In addition, measurement errors will occur when using thermocouple input. In this case, let the instrument adjust to the new environment for at least an hour before using it.
 - The life of the LCD may shorten (degradation of the image quality) if the CX2000 is used in a high-temperature environment. It is recommended that the backlight brightness of the LCD be set low if the CX2000 is installed in a hot environment (around 40°C or higher). For a description on the LCD brightness setting, see *section 3.4, "Setting the Brightness of the LCD and the Backlight Saver Function."*
-

Do not install the CX2000 in the following places.

- **Outdoors**
- **In Direct Sunlight or Near Heat Appliances**
Select a location with the smallest temperature fluctuation as possible near room temperature (23 °C). Placing the CX2000 in direct sunlight or near heat appliances can cause adverse effects.
- **Where an Excessive Amount of Soot, Steam, Dust, or Corrosive Gases Are Present**
Soot, steam, humidity, dust, and corrosive gas can cause adverse effects on the CX2000. Avoid installing the CX2000 in an environment with a high level of such elements.
- **Near Magnetic Field Sources**
Avoid bringing magnets or instruments that produce magnetic fields near the CX2000. Using the CX2000 near a strong magnetic field source can cause measurement errors.
- **Where the View of the Display Is Poor**
The CX2000 uses a 10.4" TFT color LCD for the display. Therefore, viewing of the display from an extreme angle is difficult. Install the CX2000 so that the user can easily view the display.

Installation Procedure

Use a 2 mm to 26 mm thick steel plate for the panel on which the CX2000 is to be mounted.

1. Insert CX2000 from the front of the panel.
2. Using the mounting brackets that came with the package, insert the CX2000 to the panel as shown in the following figure.
 - Two mounting brackets are used at the top and bottom or left and right of the case (remove the seal that is covering the holes of the mounting brackets on the case beforehand).
 - The adequate tightening torque of the screws for the panel mounting brackets is 0.7 to 0.9 N·m.
 - Mount the CX2000 to the panel according to the procedure below.
 - First, attach the two mounting brackets and temporarily fasten the attachment screws.
 - Next, fix the CX in place by tightening the attachment screws with the appropriate torque. When the CX is approximately perpendicular to the panel as you fasten the screws, press the mounting bracket against the case so that they are in contact with each other.

CAUTION

Tightening the screws with a torque greater than the adequate tightening torque can cause deformation of the case or damage to the bracket.

Panel Cut Diagram

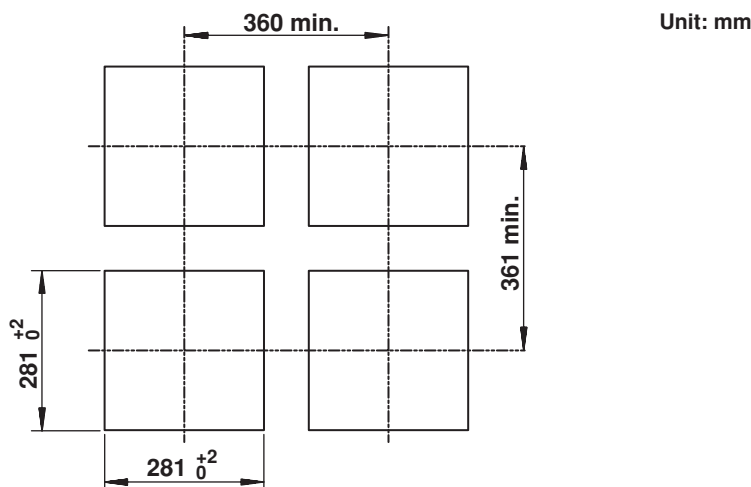

Panel Mounting Diagram

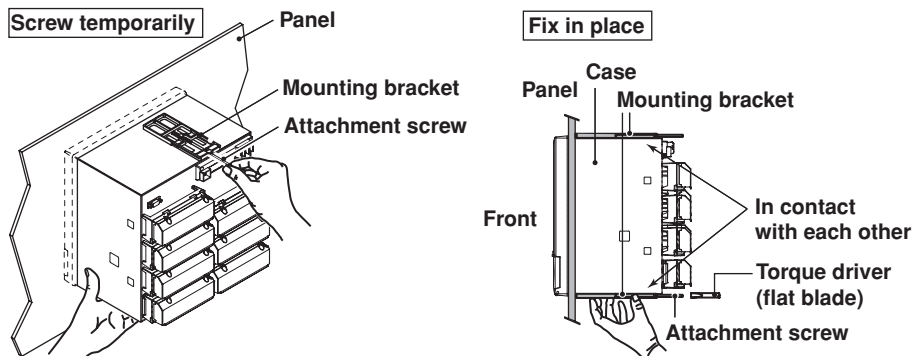

(The figure shows the case when the mounting brackets are used on the top and bottom of the case.)

2.2 Installation

External Dimensions of the CX2000

Unit: mm

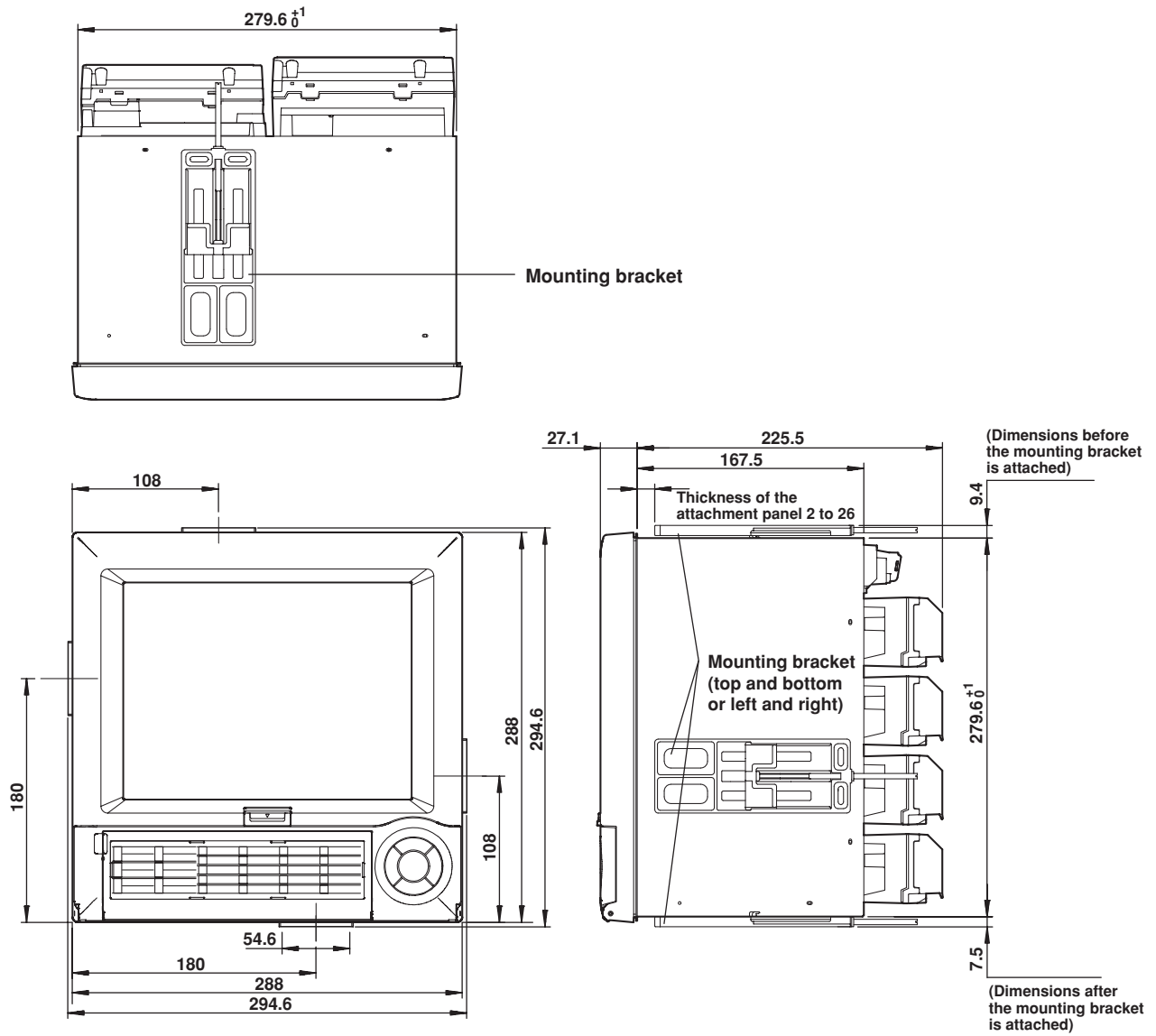

2.3 Wiring

Arrangement of the Input/Output Terminals

If you specify a model with 6 internal control loops and 20 measurement channels (CX2620) and option terminals, seven terminal blocks are arranged on the rear panel of the CX2000 as shown in the following figure. The option terminal block, which can be /A6 [measurement alarm (6 DOs)], /A6R [measurement alarm (8 DIs, 6 DOs)], /A4F [measurement alarm (4 DOs, with FAIL/memory end output relay)], /A4FR [measurement alarm (8 DIs, 4 DOs, with FAIL/memory end output relay)], /CST1 [control DIO expansion (12 DIs, 12 DOs)], or /TPS4 [24 VDC transmitter output (4 loops)], is installed at the lower left section. If several terminal blocks are not installed according to the specification made at the time of purchase, protection covers are attached in place of the corresponding terminal blocks.

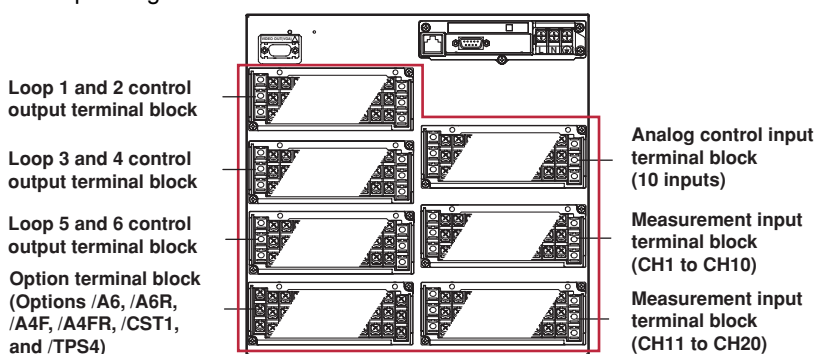

Note

- The installation position of each terminal block is fixed and cannot be changed.
- For a description on the connection of communication interfaces such as the serial or Ethernet interface, see the *DAQSTATION CX1000/CX2000 Communication Interface User's Manual*.

Input/Output Assignments of the Analog Control Input Terminal Block

There are 10 input terminals. When PV/SP computation is OFF, the PV inputs (PV) and RSP inputs (RSP) are assigned as shown in the following figure depending on the number of loops used and the control mode. The following figure denotes the three terminals (/b, +/A, -/B) of a single column using a single cell. In addition, of the 12 columns of terminals, the columns at each end that have no terminal screws because they are not used are omitted.

• **6 loops**

PV, PV1, PV2: PV input, (RSP): RSP input
(not used during program control), □: unused terminal

LOOP4		LOOP6		LOOP3		LOOP2		LOOP5		LOOP1	
2	1	1	2	1	2	1	1	2	1	2	1
(RSP)	PV	PV	(RSP)	PV	(RSP)	PV	PV	(RSP)	PV	(RSP)	PV
□	PV	□	(RSP)	PV	□	PV	□	(RSP)	PV	□	PV
PV2	PV1	□	PV2	PV1	PV2	PV1	□	PV2	PV1	□	PV2

- ← [Control mode setting]
- ← During single-loop control
- ← During cascade control
- ← During loop control with PV switching

• **4 loops**

PV, PV1, PV2: PV input, (RSP): RSP input
(not used during program control), □: unused terminal

LOOP4		LOOP3			LOOP2			LOOP1	
2	1	3	2	1	2	1	3	2	1
(RSP)	PV	□	(RSP)	PV	(RSP)	PV	□	(RSP)	PV
□	PV	□	(RSP)	PV	□	PV	□	(RSP)	PV
PV2	PV1	(RSP)	PV2	PV1	PV2	PV1	(RSP)	PV2	PV1

- ← [Control mode setting]
- ← During single-loop control
- ← During cascade control
- ← During loop control with PV switching

2.3 Wiring

• 2 loops

PV, PV1, PV2: PV input, (RSP): RSP input
(not used during program control), □: unused terminal

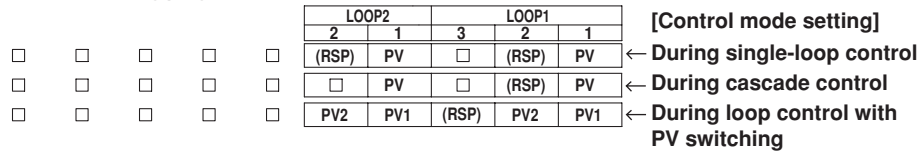

When PV/SP is ON, the numbers CI01, CI02, CI03, CI04, CI05, CI06, CI07, CI08, CI09, and CI10 are assigned to each control input terminal starting on the right as you face the terminals, and the PV/SP of each loop is the computed value.

Terminal Arrangements of the Control Output Terminal Block

Each block has a control output containing 2 loops of current output, voltage pulse output, and relay contact output terminals, 6 contact input, 2 relay contact output, and 4 transistor output terminals. The following figure shows their arrangement. Wire the terminals according to the configuration.

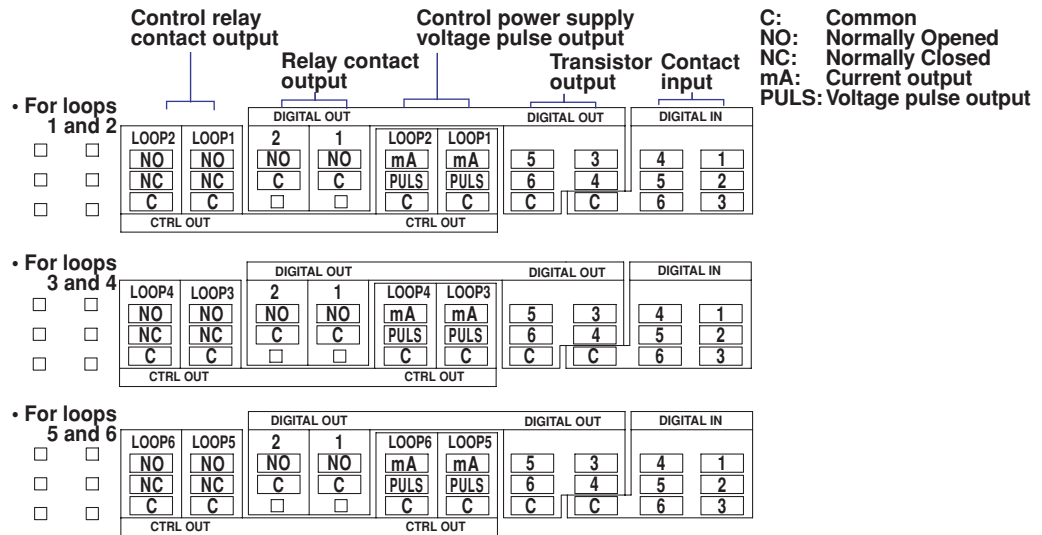

[DIGITAL OUT] terminals 1 to 6 are indicated using the following numbers when the control output terminal block is selected in the contact (relay) output registration setting or alarm relay output setting.

- DO001 to DO006 (Contact output of the loop 1 and 2 control output terminal block [CTRL1-2])
- DO101 to DO106 (Contact output of the loop 3 and 4 control output terminal block [CTRL3-4])
- DO201 to DO206 (Contact output of the loop 5 and 6 control output terminal block [CTRL5-6])

In addition, [DIGITAL IN] terminals 1 to 6 are indicated using the following numbers when the control output terminal block is selected in the contact input registration setting.

- DI001 to DI006 (Contact output of the loop 1 and 2 control output terminal block [CTRL1-2])
- DI101 to DI106 (Contact output of the loop 3 and 4 control output terminal block [CTRL3-4])
- DI201 to DI206 (Contact output of the loop 5 and 6 control output terminal block [CTRL5-6])

Note

In the contact (relay) output setting, relay contact outputs DO001, DO002, DO101, DO102, DO201, and DO202 and the numbers of transistor outputs are not distinguished. Confirm this before registering the output signals.

Terminal Arrangements of the Control DIO Expansion Terminal Block (Option Terminal Block Provided with the /CST1 Option)

12 contact input and 12 transistor contact output terminals are arranged as shown in the following figure. Wire the terminals according to the configuration.

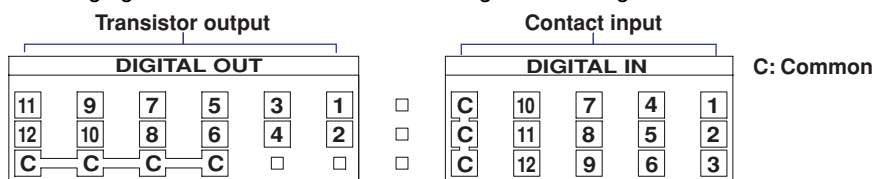

DIGITAL OUT terminals 1 to 12 are indicated using the following numbers when the control DIO expansion terminal block EXTDIO is selected in the contact (relay) output registration setting.

RO001 to RO012

In addition, DIGITAL IN terminals 1 to 12 are indicated using the following numbers when the control DIO expansion terminal block EXTDIO is selected in the contact input registration setting.

RI001 to RI012

Terminal Arrangements of the Measurement Alarm Option Terminal Block

The measurement alarm option terminal block is the terminal block that you specified as an option at the time of purchase. The following four types are available.

- /A6: 6 measurement alarm outputs
- /A6R: 6 measurement alarm outputs and 8 measurement remote inputs
- /A4F: 4 measurement alarm outputs, 1 FAIL output, and 1 memory end output
- /A4FR: 4 measurement alarm outputs, 1 FAIL output, 1 memory end output, and 8 measurement remote inputs.

The following figure shows the terminal arrangements on each measurement alarm option terminal block. Wire the terminals according to the configuration.

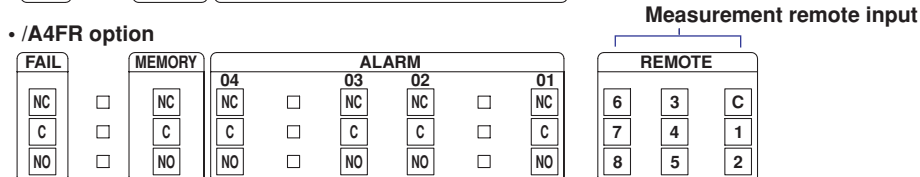
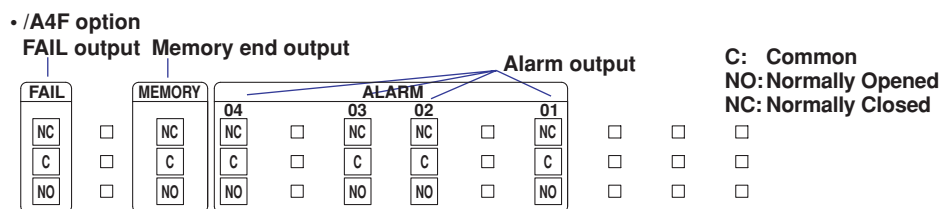
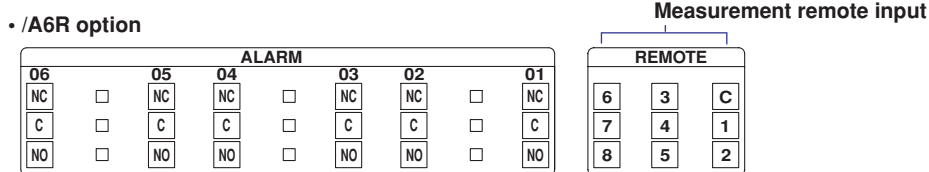
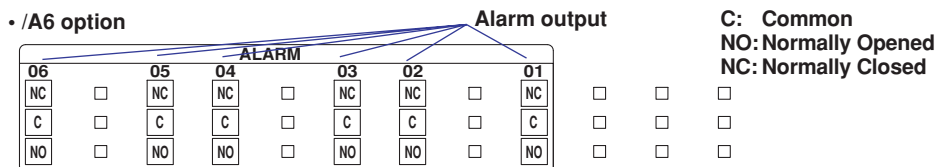

ALARM terminals 01 to 06 are indicated using [I01] to [I06] in the measurement alarm output settings (see section 7.2, "Setting Related to Measurement alarm").

REMOTE terminals 1 to 8 are indicated using numbers 1 to 8 in the measurement remote output settings (see section 11.5, "Setting the Measurement Remote Input").

Note

- There are no output registration settings for the FAIL and MEMORY terminals. However, the setting for outputting memory end, Memory Alarm Time, exists. In addition, FAIL output can be assigned to the DIGITAL OUT1 terminal of the loop 1 and 2 control output terminal block. In this case, registration settings are required.
- The control alarm output cannot be assigned to the [ALARM] terminal. The control alarm output can be assigned to the DIGITAL OUT terminal of the control output terminal block and the control extension DIO terminal block. The measurement alarm output can be assigned to the DIGITAL OUT terminal of the control output terminal block and the control extension DIO terminal block.

Terminal Arrangements of the Measurement Input Terminal Block

Ten measurement input terminals are available on each terminal block as shown in the following figure.

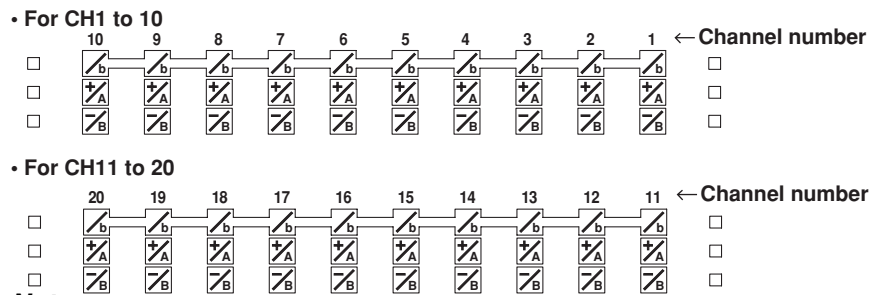

Note

In the terminal arrangement diagram of the standard terminal block shown above, b terminals are shorted with each other. If you specified the three-wire isolated RTD (/N2) option, b terminals are isolated with each other.

Terminal Cover Labels

A label showing the arrangement of the terminals is affixed to the front and back of the terminal cover of each terminal block.

Label on the Front of the Terminal Cover

The terminal numbers for checking the connection (not the numbers used in the settings) are written on the label on the front of the terminal cover (see the following figure).

- For the 6 loop analog control input terminal block

	LOOP4	LOOP6	LOOP3	LOOP2	LOOP5	LOOP1	CAT II				
<input type="checkbox"/>	031	028	025	022	019	016	013	010	007	004	<input type="checkbox"/>
<input type="checkbox"/>	032	029	026	023	020	017	014	011	008	005	<input type="checkbox"/>
<input type="checkbox"/>	033	030	027	024	021	018	015	012	009	006	<input type="checkbox"/>

- For the control DIO expansion terminal block

DIGITAL OUT						CAT II	DIGITAL IN				
634	631	628	625	622	619	<input type="checkbox"/>	613	610	607	604	601
635	632	629	626	623	620	<input type="checkbox"/>	614	611	608	605	602
636	633	630	627	<input type="checkbox"/>	<input type="checkbox"/>	<input type="checkbox"/>	615	612	609	606	603

The highest digit indicates the arrangement of the terminal block shown in the figure below; the lower two digits indicate the terminal position within the terminal block (01 is the top right terminal and 36 is the bottom left terminal). The terminals that cannot be used are indicated as “□”.

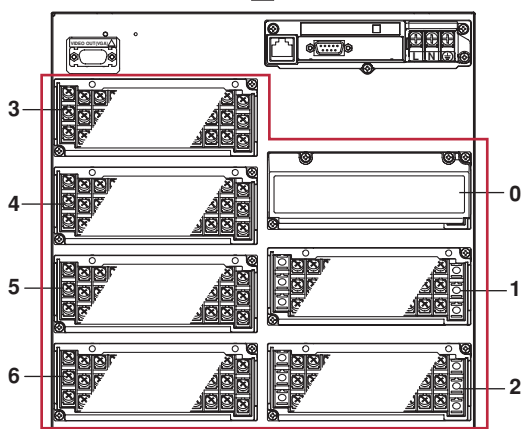

Label on the Back of the Terminal Cover

A character indicating the terminal function and a terminal symbol indicating the type of signal to be input/output to each terminal are printed on the label on the back of the terminal cover. The following figure is for the 6 loop analog control input terminal block. For a description on the wiring method corresponding to each terminal, see pages 2-10 to 2-12.

Terminal symbol

	LOOP4		LOOP6	LOOP3		LOOP2		LOOP5	LOOP1		CAT II
	2	1	1	2	1	2	1	1	2	1	△
	(RSP)	PV	PV	(RSP)	PV	(RSP)	PV	PV	(RSP)	PV	SNGL
	□	PV	□	(RSP)	PV	□	PV	□	(RSP)	PV	CAS
	PV2	PV1	□	PV2	PV1	PV2	PV1	□	PV2	PV1	PVSW

Control Input Terminal (6 loops)

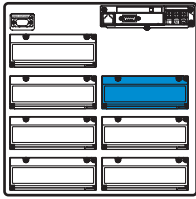

One screw terminal is shown in the figure below.

The upper and lower symbols represent a unique terminal number and the terminal type, respectively.

005 ← Terminal number
+ / A ← Characters indicating the type of input/output signal

No screw terminal is attached.

During Single-Loop Control

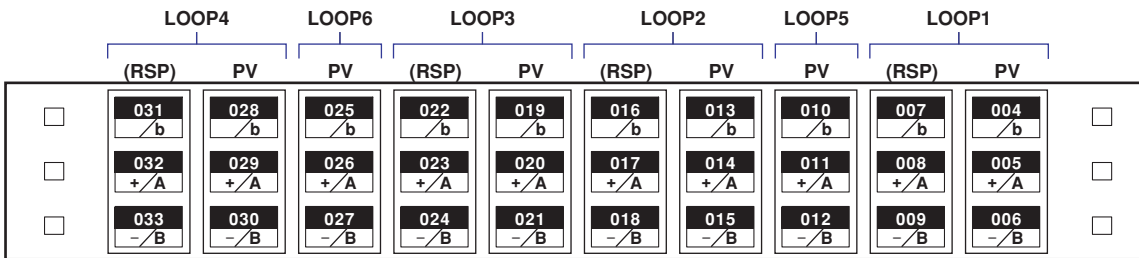

During Cascade Control

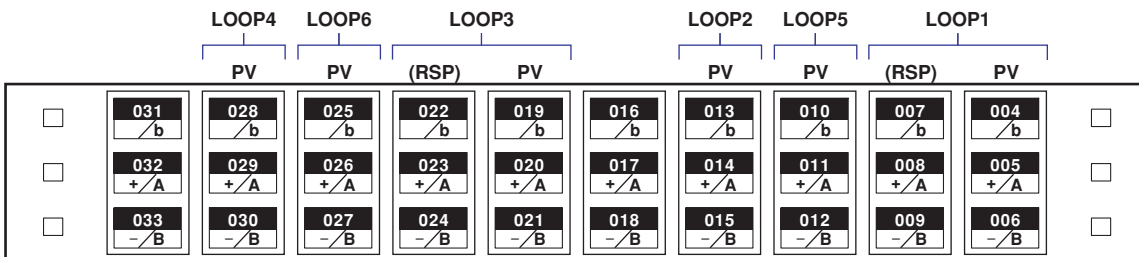

During Loop Control with PV Switching

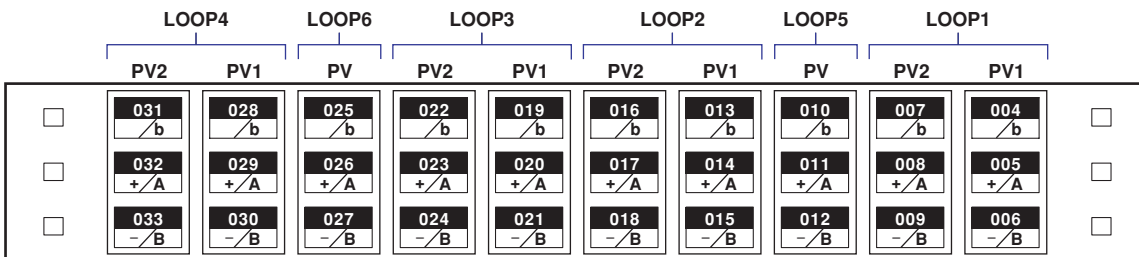

Control Modes and Input/Output Connections

Single-loop control

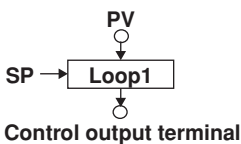

Cascade control

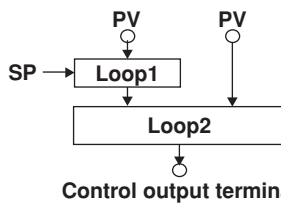

Loop control with PV switching

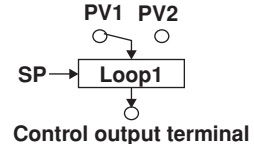

○ : Indicates a terminal.

When using remote input as target setpoints, RSP○ → replaces SP → .

Control Input Terminal (4 loops)

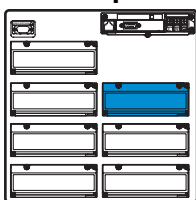

During Single-Loop Control

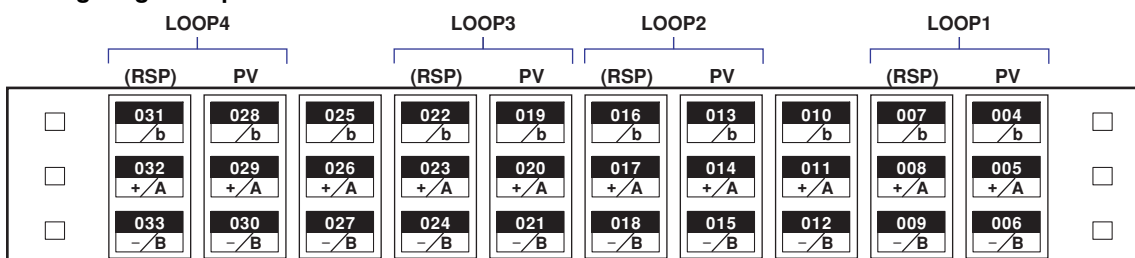

During Cascade Control

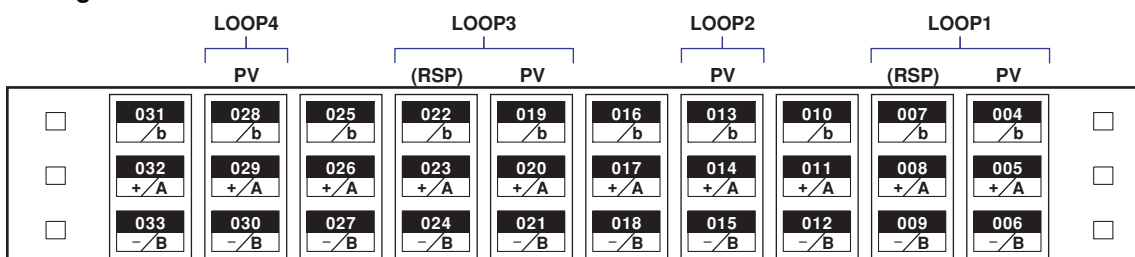

During Loop Control with PV Switching

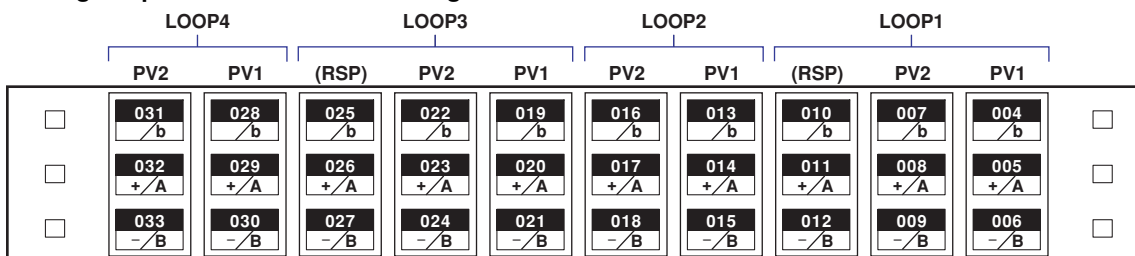

Correspondence between terminals and symbols for use in expressions for PV/SP computation or analog retransmission.

Common to 6 loops and 4 loops.

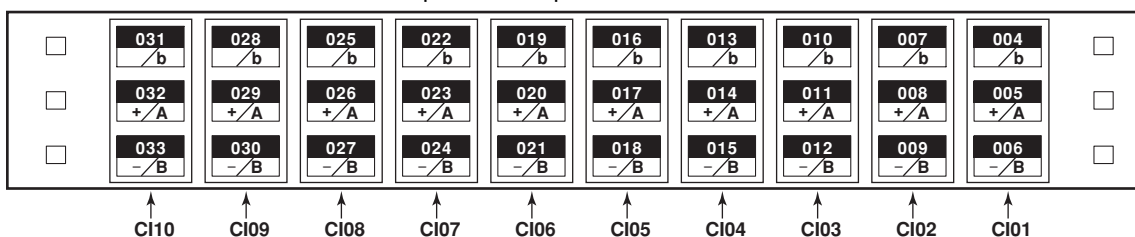

Control Input Terminal (2 loops)

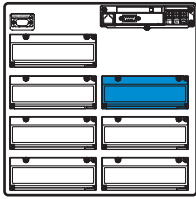

During Single-Loop Control

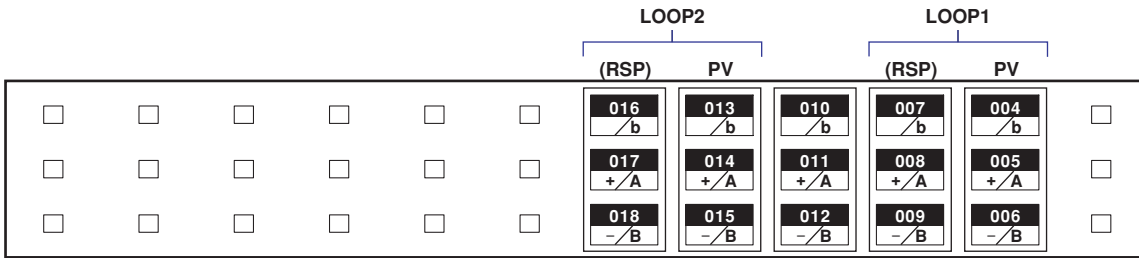

During Cascade Control

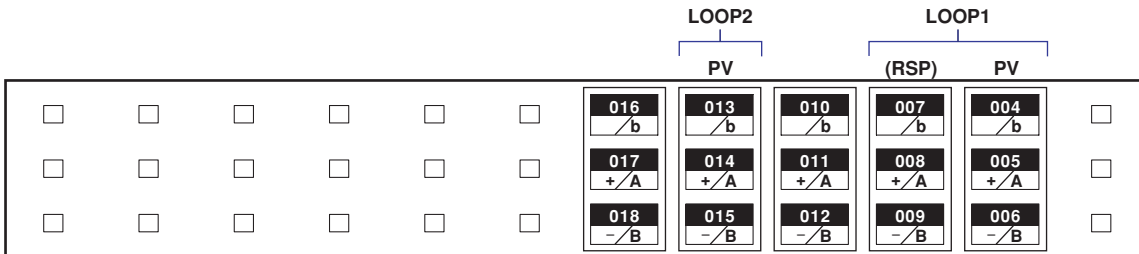

During Loop Control with PV Switching

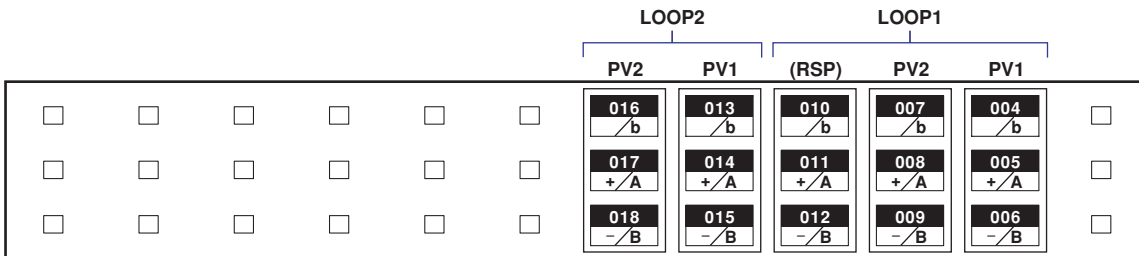

Correspondence between terminals and symbols for use in expressions for PV/SP computation or analog retransmission.

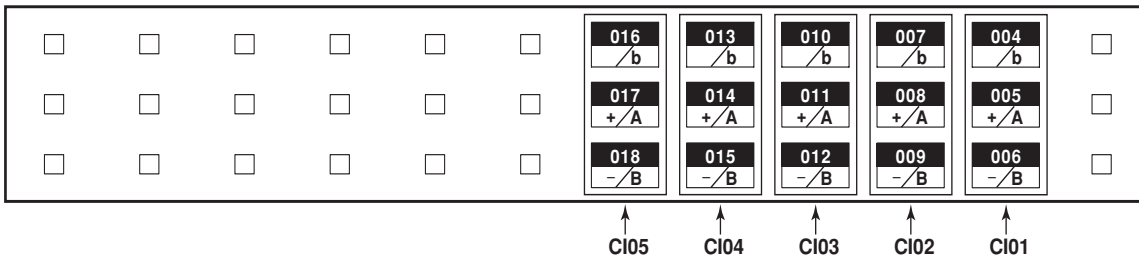

Control Output Terminal

Control Output Terminals for Loops 1 and 2

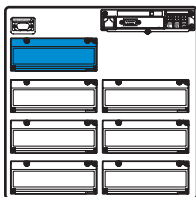

Symbols

NO: Normally opened, NC: Normally closed, C: Common
mA: Current output, PULSE: Voltage pulse output

		Control relay contact output		Relay contact output		Control current output/voltage pulse output		Transistor output		Contact input	
		LOOP2	LOOP1	2	1	LOOP2	LOOP1				
<input type="checkbox"/>	<input type="checkbox"/>	328 NO	325 NO	322 NO	319 NO	316 mA	313 mA	310 5	307 3	304 4	301 1
<input type="checkbox"/>	<input type="checkbox"/>	329 NC	326 NC	323 C	320 C	317 PULSE	314 PULSE	311 6	308 4	305 5	302 2
<input type="checkbox"/>	<input type="checkbox"/>	330 C	327 C	<input type="checkbox"/>	<input type="checkbox"/>	318 C	315 C	312 C	309 C	306 6	303 3

Control Output Terminals for Loops 3 and 4

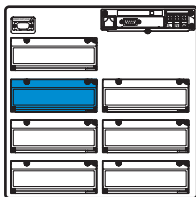

		Control relay contact output		Relay contact output		Control current output/voltage pulse output		Transistor output		Contact input	
		LOOP4	LOOP3	2	1	LOOP4	LOOP3				
<input type="checkbox"/>	<input type="checkbox"/>	428 NO	425 NO	422 NO	419 NO	416 mA	413 mA	410 5	3407 3	404 4	401 1
<input type="checkbox"/>	<input type="checkbox"/>	429 NC	426 NC	423 C	420 C	417 PULSE	414 PULSE	411 6	408 4	405 5	402 2
<input type="checkbox"/>	<input type="checkbox"/>	430 C	427 C	<input type="checkbox"/>	<input type="checkbox"/>	418 C	415 C	412 C	409 C	406 6	403 3

Control Output Terminals for Loops 5 and 6

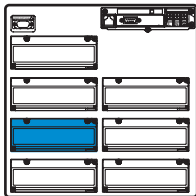

		Control relay contact output		Relay contact output		Control current output/voltage pulse output		Transistor output		Contact input	
		LOOP6	LOOP5	2	1	LOOP6	LOOP5				
<input type="checkbox"/>	<input type="checkbox"/>	528 NO	525 NO	522 NO	519 NO	516 mA	513 mA	510 5	5407 3	504 4	501 1
<input type="checkbox"/>	<input type="checkbox"/>	529 NC	526 NC	523 C	520 C	517 PULSE	514 PULSE	511 6	508 4	505 5	502 2
<input type="checkbox"/>	<input type="checkbox"/>	530 C	527 C	<input type="checkbox"/>	<input type="checkbox"/>	518 C	515 C	512 C	509 C	506 6	503 3

2.3 Wiring

Measurement Input Terminal

Measurement Input Terminal for Channels 1 to 10

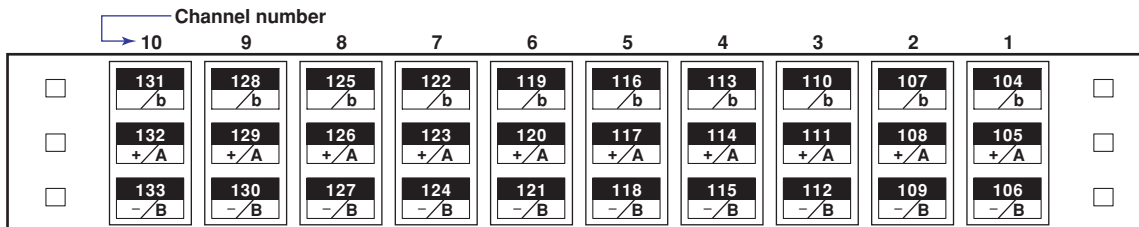
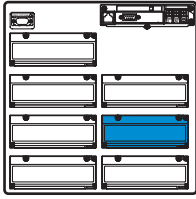

Measurement Input Terminal for Channels 11 to 20

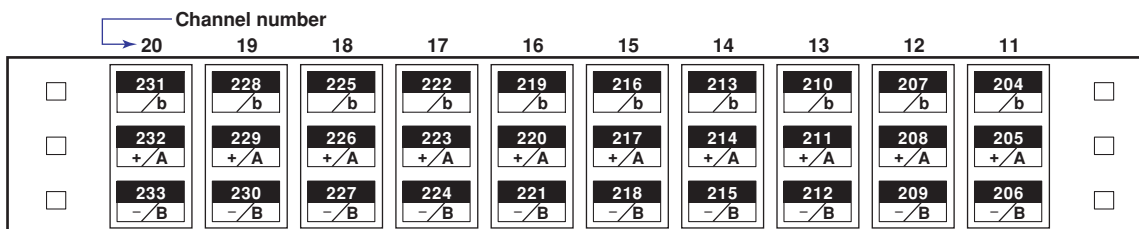
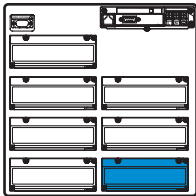

Option Terminal

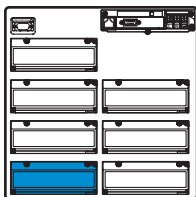

Symbols

NO: Normally opened, NC: Normally closed, C: Common

/CST1

Transistor output						Contact input					
628 11	628 9	628 7	625 5	622 2	619 1	<input type="checkbox"/>	613 C	610 10	607 7	604 4	601 1
629 12	629 10	629 8	626 6	623 4	620 2	<input type="checkbox"/>	614 C	611 11	608 8	605 5	602 2
630 C	630 C	630 C	627 C	<input type="checkbox"/>	<input type="checkbox"/>	<input type="checkbox"/>	615 C	612 12	609 9	606 6	603 3

/A6

Alarm output											
06		05		04		03		02		01	
634 NC	<input type="checkbox"/>	628 NC	<input type="checkbox"/>	625 NC	<input type="checkbox"/>	619 NC	<input type="checkbox"/>	616 NC	<input type="checkbox"/>	610 NC	<input type="checkbox"/>
635 C	<input type="checkbox"/>	629 C	<input type="checkbox"/>	626 C	<input type="checkbox"/>	620 C	<input type="checkbox"/>	617 C	<input type="checkbox"/>	611 C	<input type="checkbox"/>
636 NO	<input type="checkbox"/>	630 NO	<input type="checkbox"/>	627 NO	<input type="checkbox"/>	621 NO	<input type="checkbox"/>	618 NO	<input type="checkbox"/>	612 NO	<input type="checkbox"/>

/A6R

Alarm output							Measurement remote input			
06		05		04		03		02		01
634 NC	<input type="checkbox"/>	628 NC	<input type="checkbox"/>	625 NC	<input type="checkbox"/>	619 NC	<input type="checkbox"/>	616 NC	<input type="checkbox"/>	610 NC
635 C	<input type="checkbox"/>	629 C	<input type="checkbox"/>	626 C	<input type="checkbox"/>	620 C	<input type="checkbox"/>	617 C	<input type="checkbox"/>	611 C
636 NO	<input type="checkbox"/>	630 NO	<input type="checkbox"/>	627 NO	<input type="checkbox"/>	621 NO	<input type="checkbox"/>	618 NO	<input type="checkbox"/>	612 NO
										607 6
										604 3
										601 C
										608 7
										605 4
										602 1
										609 8
										606 5
										603 2

/A4F

FAIL output		Memory end output		Alarm output						
				04		03		02		01
634 NC	<input type="checkbox"/>	628 NC	<input type="checkbox"/>	625 NC	<input type="checkbox"/>	619 NC	<input type="checkbox"/>	616 NC	<input type="checkbox"/>	610 NC
635 C	<input type="checkbox"/>	629 C	<input type="checkbox"/>	626 C	<input type="checkbox"/>	620 C	<input type="checkbox"/>	617 C	<input type="checkbox"/>	611 C
636 NO	<input type="checkbox"/>	630 NO	<input type="checkbox"/>	627 NO	<input type="checkbox"/>	621 NO	<input type="checkbox"/>	618 NO	<input type="checkbox"/>	612 NO
										<input type="checkbox"/>
										<input type="checkbox"/>
										<input type="checkbox"/>

2.3 Wiring

/A4FR

FAIL output		Memory end output		Alarm output				Measurement remote input				
				04	03	02	01					
634 NC	<input type="checkbox"/>	628 NC	<input type="checkbox"/>	625 NC	<input type="checkbox"/>	619 NC	616 NC	<input type="checkbox"/>	610 NC	607 6	604 3	601 C
635 C	<input type="checkbox"/>	629 C	<input type="checkbox"/>	626 C	<input type="checkbox"/>	620 C	617 C	<input type="checkbox"/>	611 C	608 7	605 4	602 1
636 NO	<input type="checkbox"/>	630 NO	<input type="checkbox"/>	627 NO	<input type="checkbox"/>	621 NO	618 NO	<input type="checkbox"/>	612 NO	609 8	606 5	603 2

/TPS4

24VDC transmitter power supply output

06												
634 +	631 +	628 +	625 +	<input type="checkbox"/>	<input type="checkbox"/>	<input type="checkbox"/>	<input type="checkbox"/>	<input type="checkbox"/>	<input type="checkbox"/>	<input type="checkbox"/>	<input type="checkbox"/>	<input type="checkbox"/>
635 -	632 -	629 -	626 -	<input type="checkbox"/>	<input type="checkbox"/>	<input type="checkbox"/>	<input type="checkbox"/>	<input type="checkbox"/>	<input type="checkbox"/>	<input type="checkbox"/>	<input type="checkbox"/>	<input type="checkbox"/>
<input type="checkbox"/>	<input type="checkbox"/>	<input type="checkbox"/>	<input type="checkbox"/>	<input type="checkbox"/>	<input type="checkbox"/>	<input type="checkbox"/>	<input type="checkbox"/>	<input type="checkbox"/>	<input type="checkbox"/>	<input type="checkbox"/>	<input type="checkbox"/>	<input type="checkbox"/>

General Precautions When Wiring the Input/Output Signal Wires



WARNING

- To prevent the possibility of electric shock when wiring, confirm that the power supply source is turned OFF.
- If a voltage greater than or equal to 30 VAC/60 VDC is going to be applied to the output terminals, use round crimp-on lugs with insulation covers (to prevent the wires from coming loose) for connecting the signal wires on all output terminals. In addition, use double insulated wires (withstand voltage of 2300 VAC or more) for signal wires to which a voltage greater than or equal to 30 VAC/60 VDC is to be applied and basic insulation wires (withstand voltage of 1350 VAC or more) for all other signal wires. To prevent the possibility of electric shock, attach the terminal cover after connecting the wires and keep your hands away from the terminals.



CAUTION

- If a large pulling force is applied to the input/output signal wires connected to the CX2000, the terminal or signal wire may become damaged. To prevent this from happening, fix all the wiring cords to the rear of the installation panel.
- To prevent fire, use signal wires having a temperature rating of 70°C or more.
- Do not apply a voltage exceeding the following value to the input terminals. Otherwise, damage to the unit may result.
 - Maximum input voltage
 - Voltage range less than or equal to 2 VDC and thermocouples: ± 10 VDC
 - Voltage range between 6 and 50 VDC: ± 60 VDC
 - Maximum common mode noise voltage
 - 250 VACrms (50/60 Hz)
- The CX2000 is an installation category II product.
- Use the following circuit voltage for the connection to the alarm/FAIL/Memory End output terminal.
 - When the connection is to Mains Circuits (primary AC power source circuits): 150 V or less
 - When the connection is to circuits derived from Mains Circuits (secondary circuits): 250 V or less
(Mains Circuits voltage is less than 300 V, and connection must be used by isolation transformer.)

It is recommended that crimp-on lugs with isolation sleeves (for 4-mm screws) be used when connecting the input/output signal wires to the terminals.



For 4-mm screws

Ensure that noise does not enter the measurement circuit.

- Keep the measurement circuit away from the power supply cable (power supply circuit) and ground circuit.
- It is desirable that the object under measurement is not a noise source. However, if this is not avoidable, insulate the object under measurement and the measurement circuit. In addition, ground the object under measurement.
- Shielded wires are effective against noise caused by electrostatic induction. As necessary, connect the shield to the ground terminal of the CX2000 (make sure this does not lead to grounding at two points).
- Twisting the measurement circuit wires at short intervals is relatively effective against noise caused by electromagnetic induction.
- Make sure to ground the protective ground terminal through a small grounding resistance (less than or equal to 100 Ω).

2.3 Wiring

When using the reference junction compensation of the CX2000 through thermocouple input, take measures to stabilize the temperature at the terminal section.

- Always attach the terminal cover.
- Do not use thick wires with high heat radiations effects (cross-sectional area of 0.5 mm² or smaller recommended).
- Keep the ambient temperature consistent. Large temperature fluctuations can occur as a result of such things as turning ON/OFF a nearby fan.

To protect the control current output/voltage pulse output section from external noise such as electrical surges, it is recommended that an external surge protector (such as AR-SA (for current output) or AR-LP (for voltage pulse output) by Yokogawa M&C Corporation) be connected.

Connecting the input wires in parallel with other instruments may mutually affect the measured values. If you need to make a parallel connection:

- Turn OFF burnout.
- Ground each instrument at a single common point.
- Do not turn ON/OFF the instrument during operation. It may cause adverse affects on other instruments.
- Resistance temperature detectors cannot be connected in parallel.

Wiring Procedure

1. Turn OFF the power to the CX2000 and remove the terminal cover.
2. Wire the signal wires to the terminals.
3. Attach the terminal cover and secure it with screws.

Measurement Input Wiring

• Thermocouple input

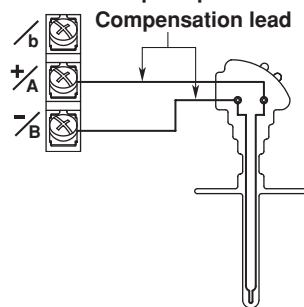

• RTD input

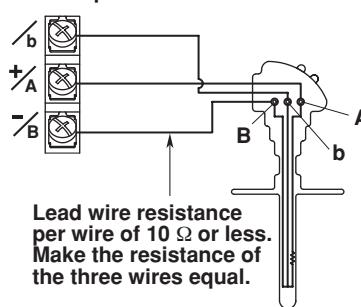

• DC voltage input, DI (ON/OFF) input

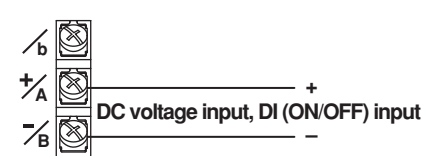

• DC current input

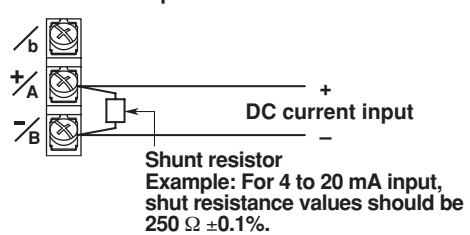

Note

On the standard measurement input block, RTD input terminals A and B are isolated on each channel. Terminal b is shorted internally across all channels. If you specified the three-wire isolated RTD (/N2) option, b terminals are isolated with each other.

Contact Input (DIGITAL IN/REMOTE) Wiring

Control output terminal block (DIGITAL IN)

• Relay contact input

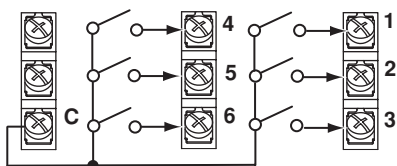

• Transistor input

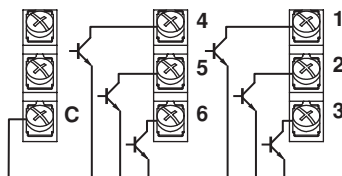

Control expansion DIO terminal block (DIGITAL IN)

• Relay contact input

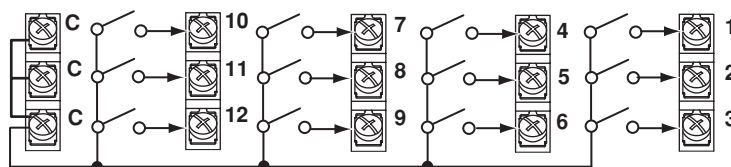

• Transistor input

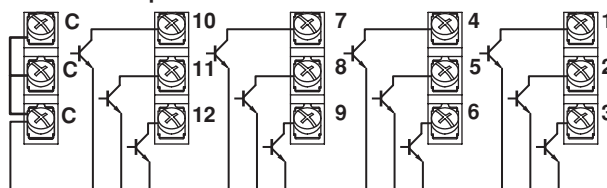

Measurement remote input (REMOTE) of the measurement alarm option terminal block (/A6R, /A4FR)

• Relay contact input

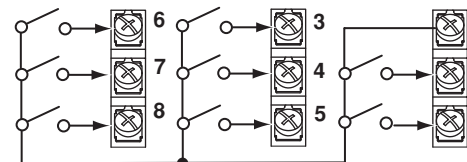

• Transistor input

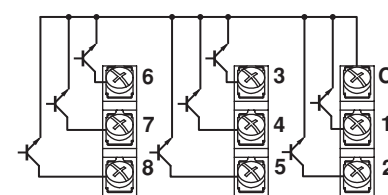

Relay Contact Input and Transistor Input Specifications

- Input signal: Non-voltage contact, open collector
- Input conditions: 0.5 V or less (30 mADC) when turned ON, leakage current of 0.25 mA or less when turned OFF
- Input format: Photocoupler isolation (shared common)
- Withstand voltage: 500 VDC for 1 minute (between the input terminal and earth)

Contact Output (ALARM, FAIL, MEMORY of the Measurement Alarm Option Terminal Blocks) Wiring

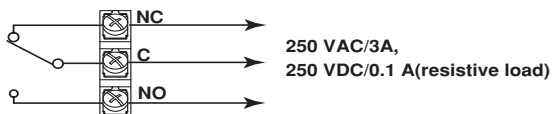

Relay Output Specifications

- Output format: Relay contact
- Contact rating: 250 VAC (50/60 Hz)/3 A or 250 VDC/0.1 A (resistive load)

Control Output (LOOP1 to 6) Wiring

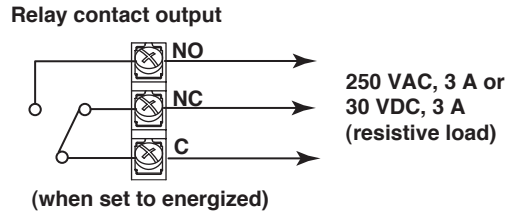
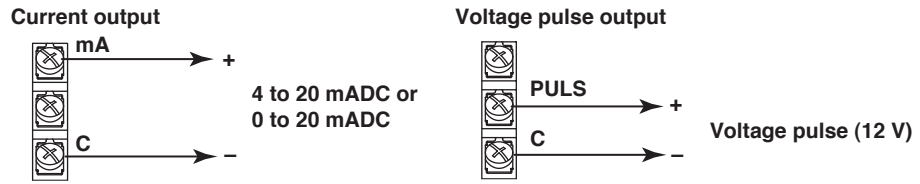

Current Output Specifications

Output signal: 4 to 20 mADC or 0 to 20 mADC
 Load resistance: 600 Ω or less

Voltage Pulse Output Specifications

Output signal: ON voltage = 12 VDC
 Load resistance: 600 Ω or more

Relay Contact Output Specifications

Output signal: NC, NO, COM
 Contact rating: 250 VAC (50/60 Hz)/3 A or 30 VDC/3 A (resistive load)

Contact Output (DIGITAL OUT) Wiring

Relay contact output of the control output terminal block

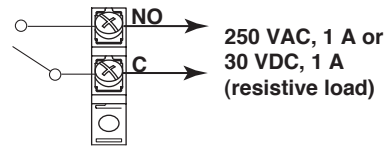

Transistor output of the control output terminal block

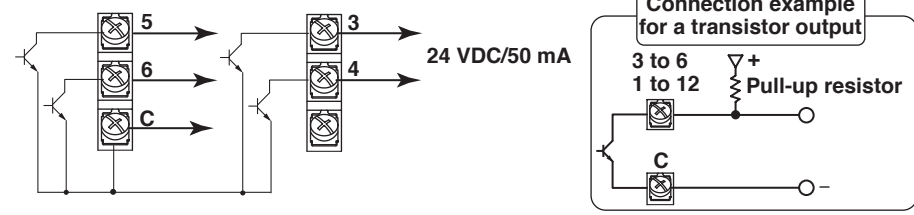

Transistor output of the control expansion DIO terminal block

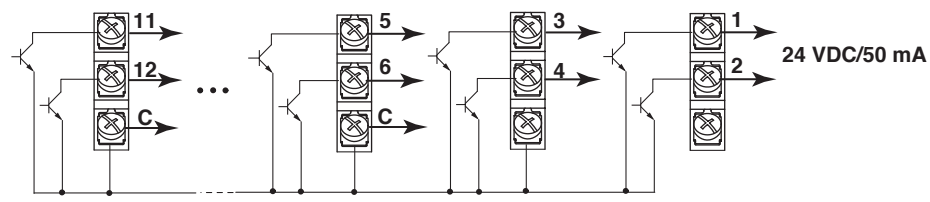

Relay Output Specifications

Output format: Relay contact
 Contact rating: 250 VAC (50/60 Hz)/1 A or 30 VDC/1 A (resistive load)

Transistor Output Specifications

Output format: Open collector output
 Contact rating: 24 VDC/50 mA

2.4 Connecting the Power Supply

Precautions to Be Taken When Wiring the Power Supply

Make sure to follow the warnings below when wiring the power supply. Otherwise, electric shock or damage to the CX2000 may result.



WARNING

- To prevent the possibility of electric shock when wiring, confirm that the power supply source is turned OFF.
- To prevent the possibility of fire, use a power line or cord that is equivalent to 600 V PVC insulated wire (AWG 18) or better.
- Make sure to ground the protective ground terminal through a grounding resistance of less than or equal to 100 Ω before turning ON the power.
- Use crimp-on lugs with isolation sleeves (for 4-mm screws) for power supply wires and protective grounding wires.
- To prevent the possibility of electric shock, make sure to close the cover (transparent) for the power supply wires.
- Furnish a switch (double-pole type) to separate the CX2000 from the main power supply in the power supply line. In addition, make sure to indicate that the switch is a power control for the CX2000 on the switch and the ON/OFF positions of the switch.

Switch Specifications

Steady-state current rating: 1 A or more, inrush current rating: 60 A or more
Use a switch complied with IEC60947-1, 3.

- Connect a fuse between 2 A and 15 A in the power supply line.
- Do not add a switch or fuse to the ground line.

Item	Not /P1 Option Specification	/P1 Option Specification
Rated supply voltage:	100 to 240 VAC	24 VDC/AC
Supply voltage range used:	90 to 132, 180 to 264 VAC	21.6 to 26.4 VDC/AC
Rated supply voltage frequency:	50/60 Hz	For AC: 50/60 Hz
Permitted supply voltage frequency range:	50/60 Hz \pm 2%	For AC: 50/60 Hz \pm 2%
Maximum power consumption:	75 VA (100 V), 106 VA (240 V)	For DC: 41 VA For AC: 60 VA

Note

Do not use a supply voltage in the range 132 to 180 VAC, as this may have adverse effects on the measurement accuracy.

Wiring Procedure

1. Turn OFF the CX2000 and open the cover (transparent) for the power supply wires.
2. Connect the power cord and the protective ground cord to the power supply terminals. The proper torque for tightening the screw is 1.4 to 1.5 N·m (12.4 to 13.2 inch·lbs).

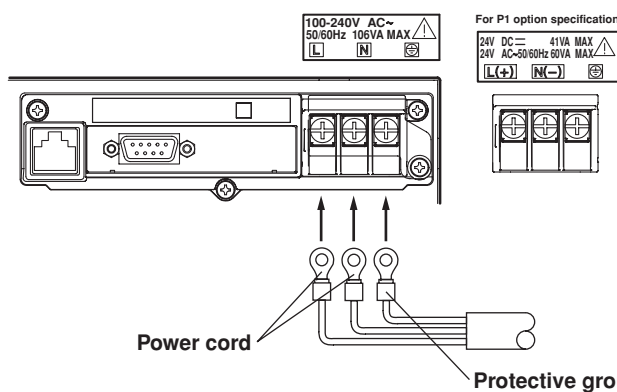

3. Close the cover (transparent) for the power supply wires and secure it in place with screws.

2.5 Connecting a Monitor to the VGA Output Terminal (/D5 Option)



CAUTION

- Connect the cable after turning OFF the CX2000 and the monitor.
- Do not short the VIDEO OUT terminal or apply external voltage to it. This may cause damage to the CX2000.

Location of the VGA Output Terminal

The VGA output terminal is the D-sub connector labeled VIDEO OUT(VGA) at the upper left corner of the rear panel of the CX2000.

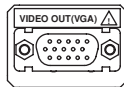

Functions and Specifications of the VGA Output Terminal

The CX2000 display can be output to a monitor through RGB output. Monitors that can be connected are VGA monitors or multi-sync monitors capable of displaying VGA.

Pin Assignments and Specifications of the VGA Output Terminal

Pin No.	Signal Name	Specifications
1	Red	0.7 Vp-p
2	Green	0.7 Vp-p
3	Blue	0.7 Vp-p
4	—	
5	—	
6	GND	
7	GND	
8	GND	
9	—	
10	GND	
11	—	
12	—	
13	Horizontal sync signal	Approx. 31.5 kHz, TTL negative logic \square
14	Vertical sync signal	Approx. 60 Hz, TTL negative logic \square
15	—	

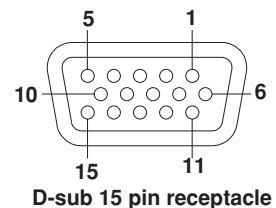

Connecting to the Monitor

1. Turn OFF the CX2000 and the monitor.
2. Connect the CX2000 and the monitor using an analog RGB cable.
3. Turn ON the power to both the CX2000 and the monitor. The screen of the CX2000 is displayed on the monitor.

Note

- When the CX2000 is turned ON, a VGA signal is always output from the VGA output terminal.
- The monitor screen may flicker if the CX2000 or another instrument is brought close to the monitor.
- The edge of the screen may drop out depending on the monitor type.

2.6 Transmitter Power Supply Wiring (/TPS4 Option)



WARNING

- To prevent the possibility of electric shock when wiring, confirm that the power supply source is turned OFF.



CAUTION

- Do not short the transmitter power supply output terminal or apply external voltage to it. This may cause damage to the CX2000.
- Do not use current that exceeds the maximum output current (25 mADC). This may cause damage to the CX2000.
- To prevent fire, use signal wires having a temperature rating of 70°C or more.

Output Specifications

Number of loops:	4
Output voltage:	22.8 to 25.2 V (under rated load current)
Rated output current:	4 to 20 mADC
Maximum output current:	25 mADC (overcurrent protection operation current: approx. 68 mADC)
Maximum length of cable:	2 km (when using the CEV cable)

Connection

To use the transmitter output as a measurement input, connect the CX2000 and transmitter as shown below.

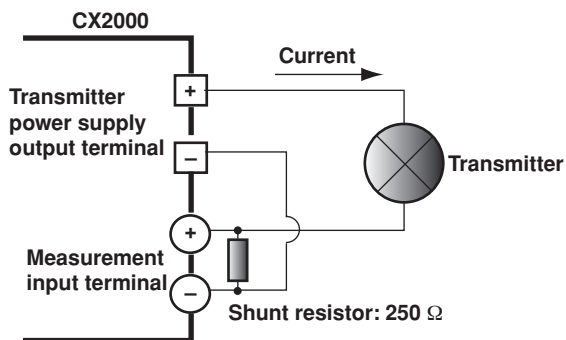

Terminal Position

Arrangement Position of Terminal Block

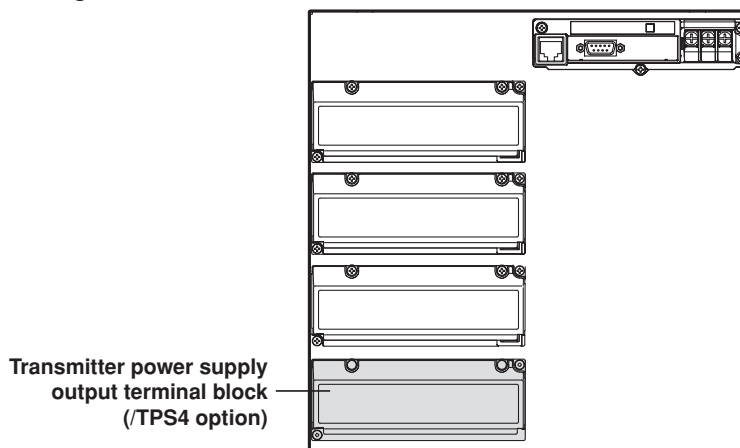

2.6 Transmitter Power Supply Wiring (/TPS4 Option)

Terminal Position

Transmitter power supply
output terminal
(4 sets of terminals)

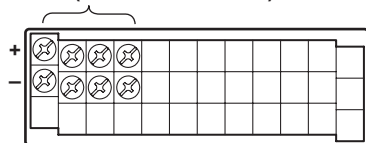

Wiring Procedure

1. Turn OFF the power to the CX2000 and remove the option terminal cover.
2. Wire the transmitter power supply output cable to one of the transmitter power supply output terminals.
3. Attach the option terminal cover and secure it with screws.

Note

To reduce noise, use a shielded cable for wiring. Connect the shield to the ground terminal of the CX2000.

3.1 Names and Functions of Sections

Front Panel

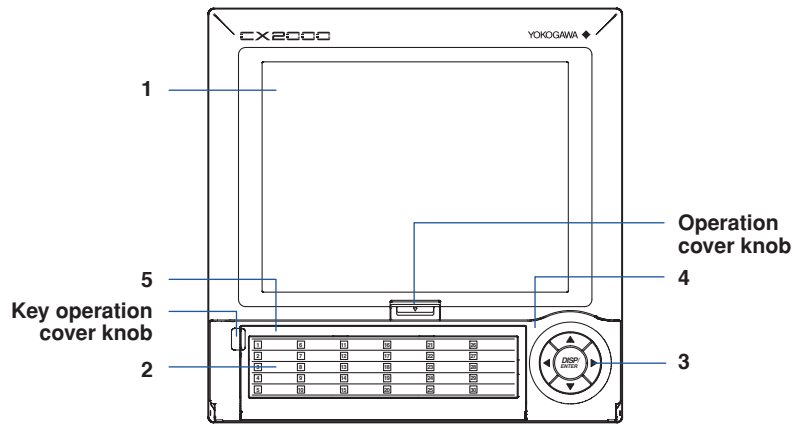

1. LCD

Various screens appear in the LCD, such as the control group display and setup displays.

For a description of each display screen, see section 3.2, “Basic Key Operations.”

2. Label

Used to identify each channel. Write the appropriate information on the label as needed.

3. Keys

Includes the left, up, and down arrow keys, as well as the DISP/ENTER key.

In operation mode, these keys are used to switch between the operation displays. In the setup screens where functions are configured, the keys are used to select parameters and to confirm new settings.

4. Operation Cover

If you need to insert or remove the external storage medium, you can open the operation cover by pressing down on the operation cover knob that is located at the upper section of the cover and pulling it forward. Make sure to have the operation cover closed at all times except when handling the external storage medium.

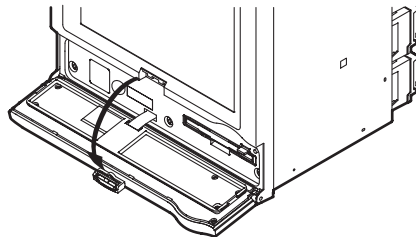

For the names and functions of parts of the operation section, see the next page.

5. Key Operation Cover

This cover is opened when you access the keys other than the arrow keys and the DISP/ENTER key. The key operation cover opens by pulling the key operation cover knob at the upper left corner of the cover forward.

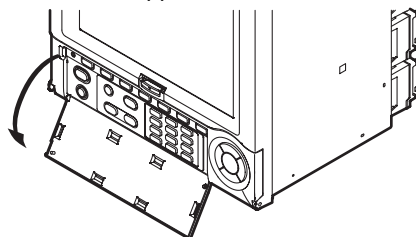

For the names and functions of parts of the key operation section, see the next page. For a description on how to operate the keys, see section 3.2, “Basic Key Operations.”

Operation Section

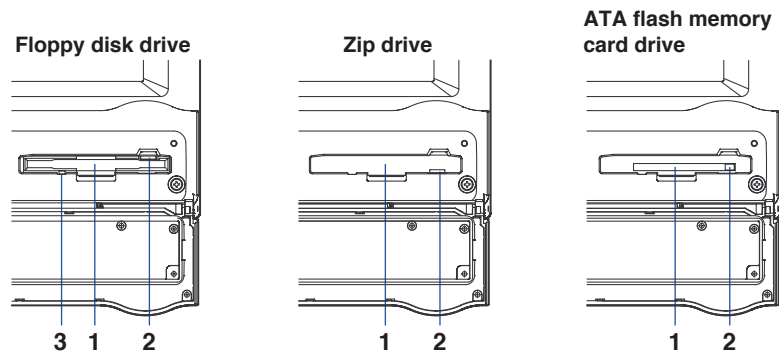

- 1. Drive for external storage medium**
Depending on the specification you made at the time of purchase, a floppy disk drive, a Zip drive, or an ATA flash memory card drive is installed.
- 2. Eject button (Zip disk access lamp)**
Used when ejecting the external storage medium. On a Zip drive, the button is also an access lamp. It illuminates when data is being written or read.
- 3. Floppy disk access lamp**
Illuminates when data is being written or read.

Key Operation Section

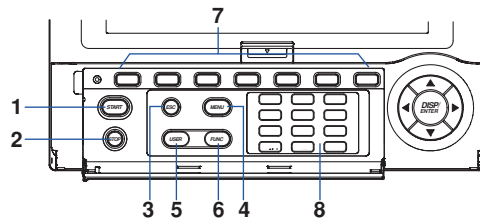

- 1. START key**
Starts the data acquisition to the internal memory, and displays the waveform on the trend display.
- 2. STOP key**
Stops the data acquisition to the internal memory. Also stops the updating of the waveform on the trend display.
- 3. ESC key**
Used when canceling an operation. Also used when returning from setting mode to operation mode.
- 4. MENU key**
Used when switching from operation mode to setting mode. Also used when returning from setting mode to operation mode.
- 5. USER key**
Used to execute the assigned action.
- 6. FUNC key**
If the key is pressed in operation mode, a soft key menu is displayed at the bottom section of the display enabling the execution of various functions. The key is also used when switching from setting mode to operation mode.
- 7. Soft keys**
When a soft key menu is displayed at the bottom section of the display in operation, setting, or basic setting mode, these soft keys are used to change the operation and setup information.
- 8. Character/Number Input Keys**
Used when entering characters or numbers.

The information above explains the basic functions of each key. For a description on how to operate the keys, see *section 3.2, "Basic Key Operations."*

Rear Panel

The terminal block that is installed in the rear panel varies depending on the specification you made at the time of purchase. Protection covers are attached in the locations where no terminal blocks are installed.

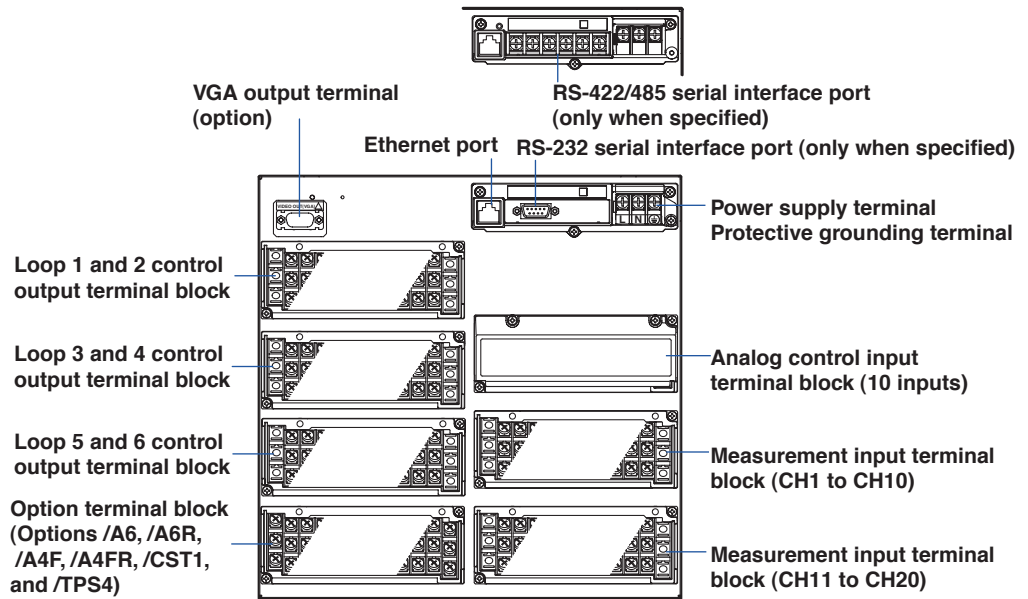

For a description on how to connect the input/output signal wires, power supply, and transmitter power supply output wires and how to use the VGA output terminal, see *chapter 2, "Installation and Wiring."*

For a description on how to use the communication ports, see the *DAQSTATION CX1000/CX2000 Communication Interface User's Manual (IM 04L31A01-17E)*.

3.2 Basic Key Operations

Switching Operation Modes

The CX2000 has four operation modes: operation mode, control setting mode, common, and measurement setting mode, and basic setting mode. Many of the settings in basic setting mode are prerequisites for the settings made in control, and common and measurement setting modes. Therefore, enter these settings first.

Mode Types	Description	Main Operations Possible
Operation mode	Mode used to monitor and control the operation. Contains a display that shows the control status, a display for turning the control, and a display for displaying the measured/computed data, etc.	<ul style="list-style-type: none"> Switch the control operation mode. Change the control parameters. Display measured/computed data. Save or abort the saving of the data.
Control setting mode	Mode used to set control-related parameters* ¹ that are changeable during operation.	<ul style="list-style-type: none"> Set the operation of control functions.
Common and measurement setting mode	Mode used to set parameters common to control and measurement and measurement-related parameters* ² that are changeable during operation.	<ul style="list-style-type: none"> Set the operation of the measurement functions. Set items related to data storage. Set items related to the display format.
Basic setting mode (setup mode)	Mode used to set basic items such as the control mode, input format, and save format of measured data. You cannot switch to the basic setting mode while control operation is progress, while data is being acquired to the internal memory, or while computation is in progress.* ²	<ul style="list-style-type: none"> Set basic items of each function. Set communication parameters.

*1 Some of the items such as the input range or computation settings cannot be changed during control operation, during data acquisition to the internal memory, and during computation.

*2 However, if the primary loop of cascade control is in operation, you can switch to basic setting mode.

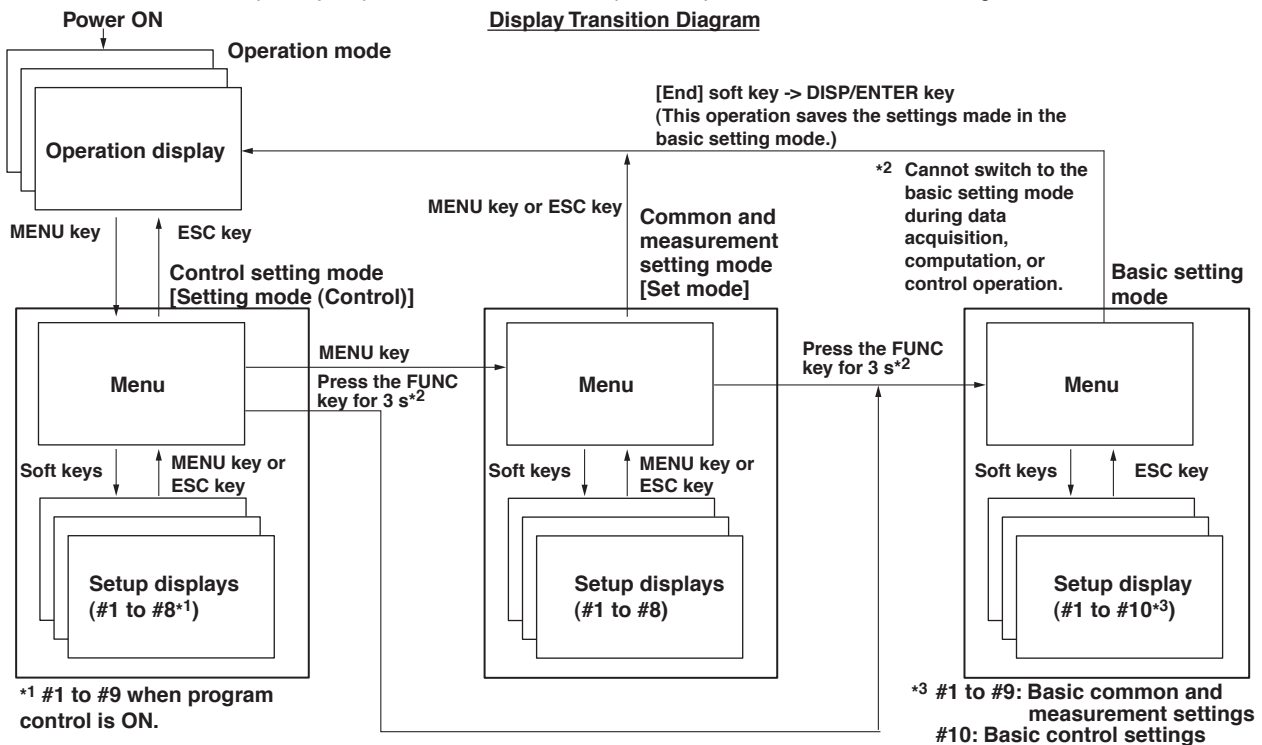

Procedure

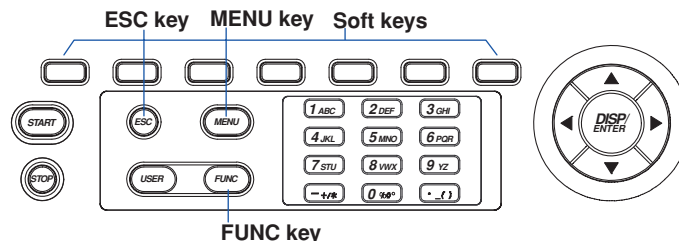

Switching the Operation Mode Display, Control Setting Menu, and Common and Measurement Setting Menu

The display switches each time the MENU key is pressed. The ESC key can also be used when switching to the operation display from the control setting menu or common and measurement setting menu.

Switching to Basic Setting Menu

1. Press the **MENU key** to display the setting (control) menu or common and measurement setting menu.
2. Press the **FUNC key** for at least 3 seconds.

Note

- You cannot switch to basic setting mode while control operation is running, while data is being acquired to the internal memory, or while the external storage medium is being accessed. Stop the control operation, data acquisition to the internal memory, and computation before switching to basic setting mode.
- If you change [PID number], [Control period], [Control mode], or [Program control] (setting available only to models with the program control option) under [#10 Control] in basic setting mode, settings in setting mode (Control) are initialized.
- If you change the settings under [#2 Memory, Memory and trend, Memory timeout] (excluding memory time up items) in basic setting mode, save the new settings and return to operation mode, the measured/computed data in the internal memory is cleared. Save important data to the external storage medium before entering basic setting mode.

Switching Displays When in Operation Mode

You can change the operation display according to your needs by carrying out the following procedures.

Operation flow

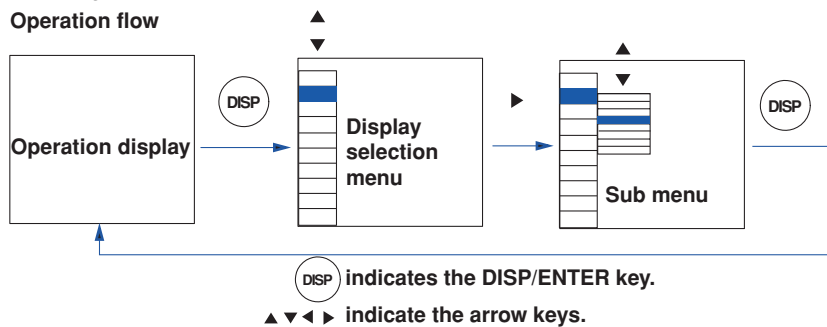

Procedure

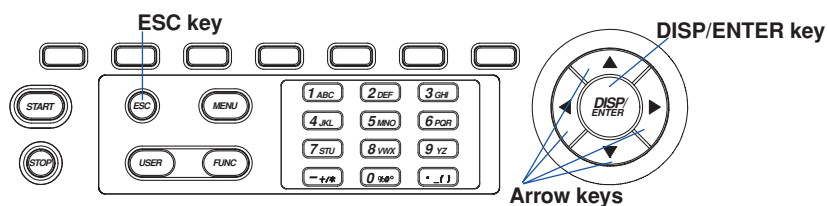

1. Press the **DISP/ENTER key** to show the display selection menu.
2. Select the menu item using the **up and down arrow keys**.
3. Press the **right arrow key** to display the sub menu.
To close the sub menu that you opened, press the left arrow.
4. Select the sub menu item using the **up and down arrow keys**.



5. Press the **DISP/ENTER key**.
The selected display appears.
To close the menu without switching the display, press the ESC key.

3.2 Basic Key Operations

FUNC Key Operation in Operation Mode

The following operation can be carried out in operation mode.

Menu	Reference	Function (conditions displayed on the soft key menu)
Alarm ACK	4.7, 7.2	Clears alarm display/relay output (valid only when the operation of the alarm display or output relay is set to "hold").
Message	8.9	Displays messages 1 to 8 on the trend display and writes them to the internal memory.
Manual sample	9.2	Acquires instantaneous values of all channels to the internal memory.
Key lock	11.2	Enables/disables key lock (only when key lock is used)
Log out	11.3	Logs out (only when logged in using the key login function)
Trigger	9.1	Trigger used to start acquiring event data to the internal memory (valid only when event data is specified to be acquired to the internal memory and the trigger used to start the acquisition is set to key trigger).
Math START/ Math STOP	10.2	Starts/stops computation (only for models with the computation option (/M1))
Math reset	10.2	Resets the computed value of the computation channel to 0 (only on models with the computation option (/M1) while the computation is stopped).
Math ACK	10.2	Recovers the computation dropout indication icon to normal indication (only on models with the computation function (/M1) when computation dropout occurs)
Snapshot	9.6	Saves the screen image data to the external storage medium.
Log	11.4	Displays the log display/system display.
FTP test	Communications*	Executes an FTP test.
4Panel	8.2	Sets the name of the 4 screen display (only when the 4 screen display is showing)
Save Display/ Save Event	9.1	Stores the display data or event data to the external storage medium (only when the display data or event data is being acquired to the internal memory in the free mode).
E-Mail START/ E-Mail STOP	Communications*	Enables/disables the e-mail transmission function.
E-Mail test	Communications*	Sends test messages to recipient 1 and 2.
Modbus master	Communications*	Displays the Modbus status when the Modbus master function is used.
External loop	Communications*	Displays the status of the external Green series communication communications.

* See the *DAQSTATION CX1000/CX2000 Communication Interface User's Manual (IM04L31A01-17E)*.

Procedure

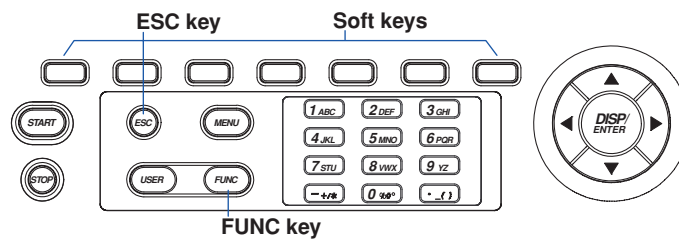

1. Press the **FUNC** key.

As shown in the following figure, menu assigned to the soft keys is displayed.



2. Press the **soft key** corresponding to the function you wish to execute.

If [Next 1/n] (where n is the number of menu lines) appears at the right end of the menu, this indicates that there are multiple lines of menus. Press the [Next 1/n] soft key to view the next menu.

Press a soft key to execute the function assigned to it. The result of the soft key being pressed varies depending on its function, as is explained in later sections of this manual.

To clear the menu without executing functions, press the FUNC or ESC key.

Key Operations on the Control Operation Display

On the control operation displays such as the control group display and tuning display, a soft key menu appears at the bottom of the display. For the operating procedure, see *chapter 6, "Operations during Control Operation."*

Operation of Other Keys in Operation Mode

Procedure

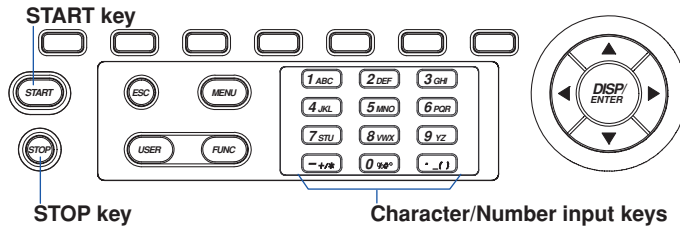

START/STOP Key

- Starts/stops the data acquisition to the internal memory. The waveform display on the trend display is also started/stopped. For the operating procedure, see section 9.1, “Acquiring Measurement Data to the Internal Memory and Saving Data to the External Storage Medium.”
- On models with the computation function option, this key is also used to start/stop the computation and report. For the operating procedure, see section 10.2, “Starting, Stopping, and Resetting the Computation.”

USER Key

Executes the function assigned to it. For the procedure in assigning a function to the USER key, see section 11.1, “USER Key Assignment and Operation.”

Character/Number Input Keys (For the procedure in entering numbers and characters, see pages 3-9 and 3-10.)

- Used to enter the password for clearing the key lock or during key login. For the operating procedure, see sections 11.2, “Key Lock” and 11.3, “Key Operation Login/Logout.”
- Used when changing the name of the 4 screen display. For the operating procedure, see section 8.2, “Using the the Four Screen Display.”

Key Operations in Basic Setting and Setting Modes

Procedure

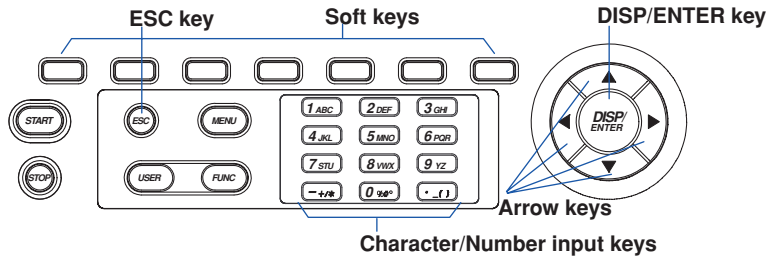

Selecting Setup Items on the Menu

When the CX2000 enters setting mode, a setting menu appears as shown in the figure below. In this menu, select the items you wish to set by pressing the soft keys. To close this menu, press the ESC key.

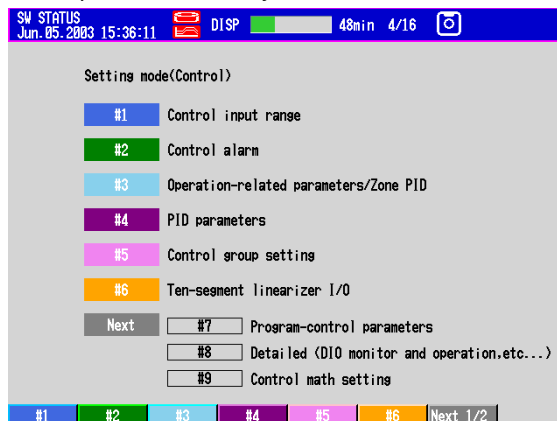

Selecting Setup Items on the Setting Display

1. Use the **arrow keys** to move the cursor (blue) to the appropriate item box.
The soft keys corresponding to the item are displayed at the bottom section of the display.
2. Select the item using the **soft key**.
The box for the item you entered turns yellow, and the cursor moves to the next item.

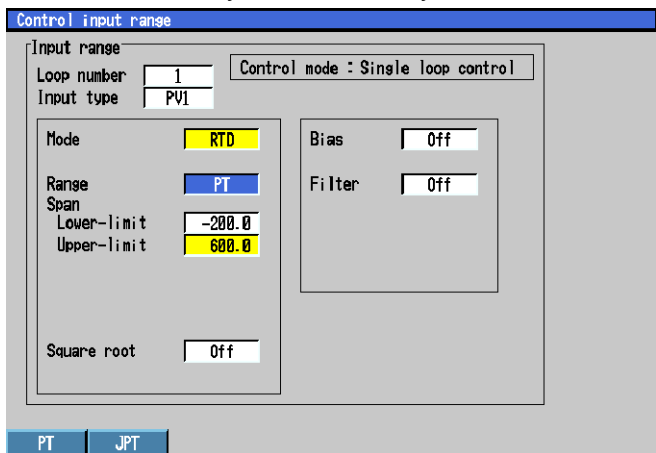

To cancel the settings, press the ESC key. On the cancel confirmation window that appears, press the DISP/ENTER key with [Yes] is selected.

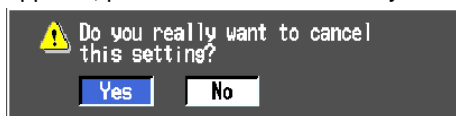

Note

If values or characters need to be entered, the soft key menu displays [Input]. For the procedure in entering values and characters, see pages 3-9 to 3-10.

Confirming Settings on the Setting Displays

Press the **DISP/ENTER key**.
The item you entered is confirmed and the item box turns white again. The cursor moves to the first item box on the setting display.

Note

If you attempt to confirm the setting by pressing the key on the setup display invoked by the [Setting mode (control)] > [Control Input Range] command sequence, a confirmation window with a message “Do you really want to change the settings?” appears.

Switching from Setting Mode to Operation Mode

Display setting menu and press the **ESC key**.

Switching from Basic Setting Mode to Operation Mode and Saving the Basic Settings

Display basic setting menu, and then carry out the following procedures.

1. Press the **[End] soft key**.
A confirmation window containing the message “Do you want to store and make the new settings take effect?” appears.
2. Select [Yes] using the **arrow keys** and press the **DISP/ENTER key**.
The settings are saved and the CX2000 returns to operation mode. If you select [No] and press the DISP/ENTER key, the settings are not saved and the CX2000 returns to operation mode. In this case, the settings remain unchanged. Selecting [Cancel] and pressing the DISP/ENTER key returns you to basic setting mode menu.

Entering Values

A value must be entered when setting items such as the date/time and span lower/upper limit. In such cases, a numeric entry pop-up window appears as shown in the following figure. Follow the procedures below to enter the value.

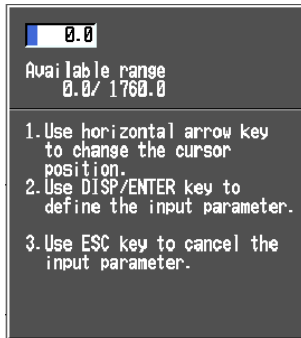

Procedure

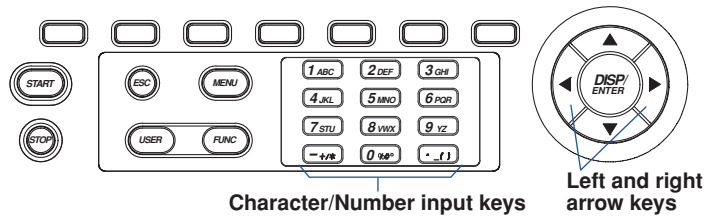

When a numeric entry pop-up window appears, enter the value using the following key operation.

- Left and right arrow keys: Selects the entry position.
- Character/number input keys: Enters the numbers, the decimal point, and the minus sign.

Note

A [Space] soft key may appear in the numeric entry mode. You can enter a space by pressing this soft key.

Entering Characters

Characters must be entered when setting items such as tag names and messages. In such cases, a character entry pop-up window appears as shown in the following figure. Follow the procedures below to enter the characters.

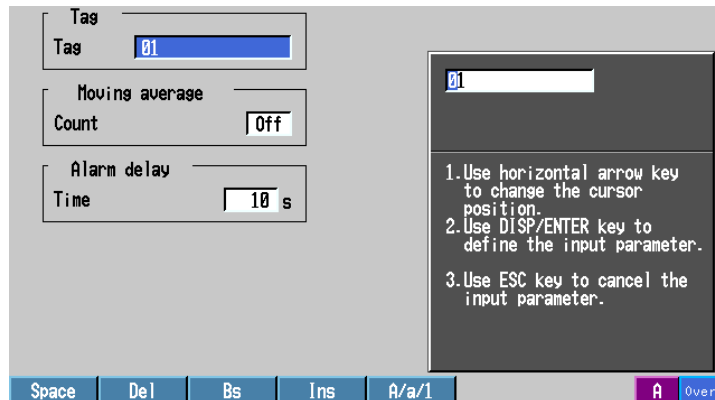

Procedure

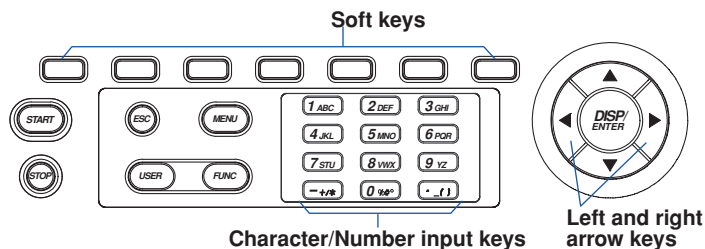

3.2 Basic Key Operations

When a character entry pop-up window appears, enter the value using the following key operation.

- Left and right arrow keys: Select the entry position.
- Character/number input keys: Enters the characters.
- [Space] soft key: Enters a space
- [DEL] soft key: Clears the character at the cursor position.
- [BS] soft key: Clears the character before the cursor position.
- [INS] soft key: Selects insert or overwrite.
Insert and overwrite mode toggles each time the [INS] soft key is pressed. The selected mode is shown on the right side of the soft key display section.
- [Copy/Paste] soft key: Used when copying character strings. Move the cursor to the string to be copied and press the [Copy] soft key. Move the cursor to the copy destination string entry box and press the [Paste] soft key.
- [Clear] soft key: Used when clearing the character string. Move the cursor to the string you wish to clear and press the [Clear] soft key.
- [A/a/1] soft key: Selects the upper-case A, lower-case a, or value 1.
The character that can be enter changes in the order shown below each time the [A/a/1] soft key is pressed. However, characters that cannot be entered are skipped. The selected character is shown on the right side of the soft key display section.
Upper-case A → lower-case a → value 1

Upper-Case Alphabet (Lower-Case Alphabet) and Symbols

Key	Pressed Once	Pressed Twice	Pressed 3×	Pressed 4×
1 ABC	A(a)	B(b)	C(c)	
2 DEF	D(d)	E(e)	F(f)	
3 GHI	G(g)	H(h)	I(i)	
4 JKL	J(j)	K(k)	L(l)	
5 MNO	M(m)	N(n)	O(o)	
6 PQR	P(p)	Q(q)	R(r)	
7 STU	S(s)	T(t)	U(u)	
8 VWX	V(v)	W(w)	X(x)	
9 YZ	Y(y)	Z(z)		
+/*	+	/	*	
0 %*	%	#	°	@
.-()	-	()	

3.3 Setting the Date and Time

This section explains how to set the date, time, and the daylight savings function of the CX2000 internal clock.

Procedure

Opening the Setting Display

• Setting the Date and Time

Press the keys in the following sequence:

MENU key (switch to Set mode) > **#6 soft key** (select [Time])

From the operation display, use the above keys to open the following setting dialog box.

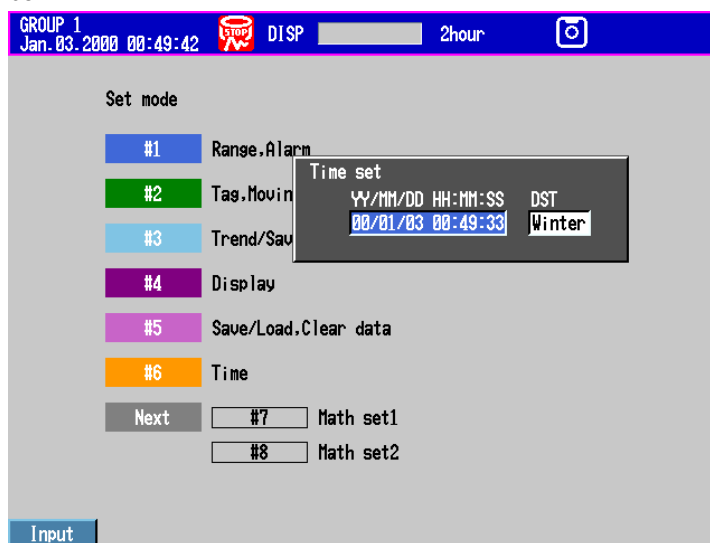

• Setting Daylight Savings Time

Press the keys in the following sequence:

MENU key (switch to setting mode (Control)) > **MENU key** (switch to Set mode) >

#3 soft key (select [Trend/Save interval, Message, File, User key, DST])

The following display appears.

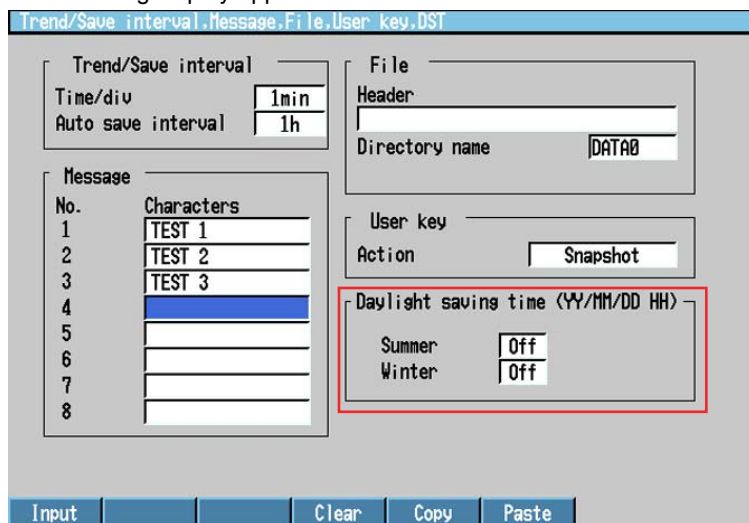

Setup Procedure

- **Setting the Date and Time**

1. Press the **[Input] soft key**.
The cursor (blue) moves to the [YY] section.
2. Enter the time using the **character/number input key**.
When you operate the keys, the word [Input] disappears from the soft key.
3. Press the **DISP/ENTER key**.
The word [Input] appears on the soft key.
4. Press the **DISP/ENTER key** again.
To cancel the settings and close the time setting dialog box, press the ESC key.

- **Setting Daylight Savings Time**

1. Use the **arrow keys** to move the cursor (blue) to the item box you wish to change.
A soft key menu is displayed at the bottom of the display.
2. Press the **soft key** corresponding to the value you wish to select.
The box for the item you changed turns yellow, and the cursor moves to the next item.
3. Repeat steps 1 and 2 to change the value of all the items you wish to change.
4. Press the **DISP/ENTER key** to confirm the changes.
The boxes for the items you changed turn from yellow to white, and the cursor returns to the first item box.

Setup Items

Daylight Savings Time

- **Summer/Winter**

- **Off/On**

When set to [On], the daylight savings time is enabled.

- **YY/MM/DD HH**

Enter the date and hour when the time is to be changed. The time is set ahead one hour at the date and hour specified for [Summer] and set back one hour at the date and hour specified for [Winter].

3.4 Setting the Brightness of the Display and the Backlight Saver Function

This section explains how to set the brightness of the LCD and the backlight saver function used to prolong the life of the LCD backlight.

Procedure

Opening the Setting Display

Press the keys in the following sequence:

MENU key (switch to Set mode) > **#4 soft key** (select [Display]) > **#4 soft key** (select [View, Direction, LCD])

The following setting display appears.

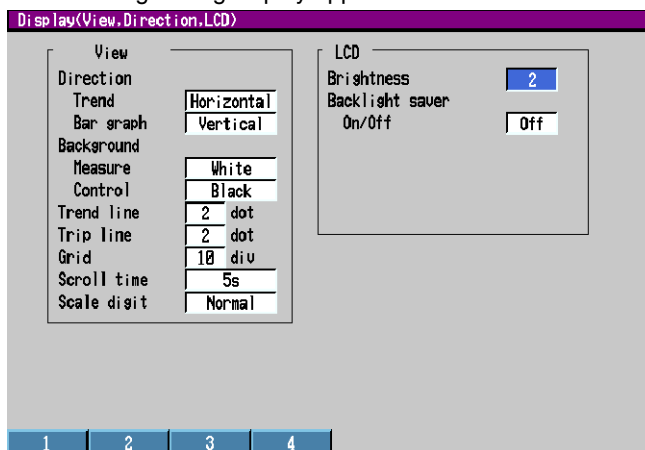

Setup Procedure

1. Use the **arrow keys** to move the cursor (blue) to the [Brightness] or [Backlight saver On/Off].
The selections are displayed at the bottom of the display.
2. Press the **soft key** corresponding to the value you wish to change.
The box for the item you changed turns yellow, and the cursor moves to the next item.
If [Backlight saver On/Off] is set to [On], [Saver time] and [Restore] entry boxes appear.
3. Repeat steps 1 and 2 to change the value of all the items you wish to change.
4. Press the **DISP/ENTER key** to confirm the changes.
The boxes for the items you changed turn from yellow to white, and the cursor returns to the first item box.

Setup Items

Display Brightness

Select a value from “1 to 4” (the initial setting is 3). The larger the value, the brighter the display becomes.

Backlight Saver Function

- **On/Off**

When set to [On], the LCD backlight automatically dims according to the specified conditions described below.

- **Saver time**

Select a value from “1 min, 2min, 5min, 10min, 30min, 1h” (factory default setting is 1h). If the specified time elapses without any key operation, the LCD backlight is automatically dimmed.

- **Restore**

Key: The backlight returns to the original brightness on a key operation.

Key + Alm: The backlight returns to the original brightness on a key operation or an alarm occurrence.

Note

The degradation of the brightness and the discoloration of the screen (become yellowish) tend to progress faster as the brightness is set higher. Extended use at an unnecessary high setting should be avoided. It is also recommended that you use the backlight saver function.

3.5 Initializing the Setup Data and Clearing the Internal Memory

This section explains how to initialize the setup data in the internal memory to factory default settings (initial settings) and how to clear the data in the internal memory. For a list of initial settings, see appendix 6.

Procedure

Opening the Setting Display

Press the keys in the following sequence:

MENU key (switch to Set mode) > **Hold down the FUNC key for 3 seconds** (switch to basic setting mode) > **#5 soft key** (select [Load, Initialize]) > **#4** (select [Initialize])

The following setting display appears.

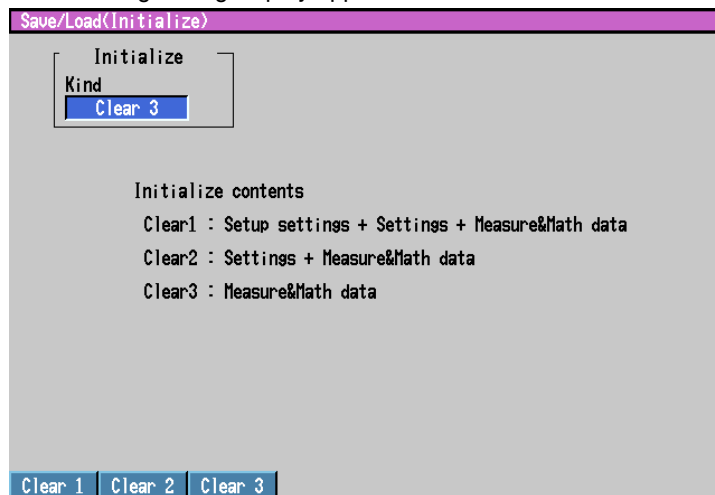

Setup Procedure

1. Use the **arrow keys** to move the cursor (blue) to the item box you wish to change. The selections are displayed at the bottom section of the display.
2. Press the **soft key** corresponding to the value you wish to change. The box for the item you changed turns yellow, and the cursor moves to the next item.
3. Repeat steps 1 and 2 to change the value of all the items you wish to change.
4. Press the **DISP/ENTER key** to confirm the changes. The boxes for the items you changed turn from yellow to white, and the cursor returns to the first item box.

Saving the Settings

1. Press the **ESC key**. The display returns to basic setting menu.
2. Press the **[End] soft key**. A confirmation dialog box appears.
3. Select [Yes] and press the **DISP/ENTER key**.

Setup Items

Select the type of operation from the following:

Clear1: Initializes the setup data of basic setting mode and setting mode and clears the data in the internal memory.

Clear2: Initializes the setup data of setting mode and clears the data in the internal memory.

Clear3: Clears the data in the internal memory.

Data That Are Cleared

Items that are cleared are, display data, event data, manual sample data, TLOG data (option), report data (option), and log information.

3.6 Changing the Displayed Language

This section explains how to change the language used on the display.

Procedure

Opening the Setting Display

Press the keys in the following sequence:

MENU key (switch to Set mode) > **Hold down the FUNC key for 3 seconds** (switch to basic setting mode) > **#9 soft key** (select [Aux])

The following setting display appears.

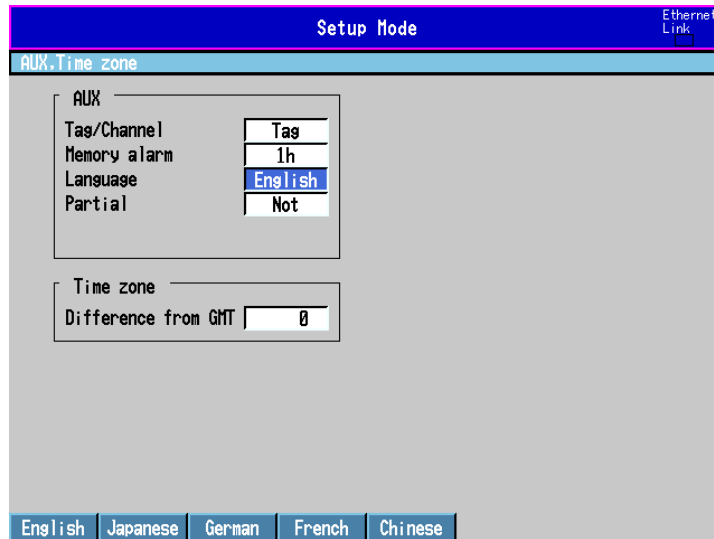

Setup Procedure

1. Use the **arrow keys** to move the cursor (blue) to the [Language] box. [English], [Japanese], [German], [French], and [Chinese] appear in the soft key menu at the bottom of the display.
2. Press the [English], [Japanese], [German], [French], or [Chinese] **soft key**. The [Language] box turns yellow, and the cursor moves to the next item.
3. Press the **DISP/ENTER key** to confirm the changes. The boxes for the items you changed turn from yellow to white, and the cursor returns to the first item box.

Saving the Settings

1. Press the **ESC key**. The display returns to basic setting menu.
2. Press the **[End] soft key**. A confirmation window appears.
3. Select [Yes] and press the **DISP/ENTER key**.

3.7 Changing the Time Zone

This section explains how to set the time difference with respect to Greenwich Mean Time. Make sure to set this value if you are using the Web server function.

Procedure

Opening the Setting Display

Press the keys in the following sequence:

MENU key (switch to Set mode) > **Hold down the FUNC key for 3 seconds** (switch to basic setting mode) > **#9 soft key** (select [Aux])

The following setting display appears.

AUX. Time zone	
AUX	
Tag/Channel	Tag
Memory alarm	1h
Language	English
Partial	Not
Time zone	
Difference from GMT	0

Input

Setup Procedure

1. Use the **arrow keys** to move the cursor (blue) to the [Difference from GMT] box under [Time zone].
[Input] is displayed at the bottom of the display.
2. Press the **[Input] soft key**.
3. Enter the time difference using the **character/number input keys** and **soft keys**.
4. Press the **DISP/ENTER key**.
5. Press the **DISP/ENTER key** to confirm the changes.

Saving the Settings

1. Press the **ESC key**.
The display returns to basic setting menu.
2. Press the **[End] soft key**.
A confirmation window appears.
3. Select [Yes] and press the **DISP/ENTER key**.

Setup Items

Set the time difference with respect to Greenwich Mean Time from -1200 to 1200 (the upper two digits indicate the hour; the lower two digits indicate the minute).

Example: The standard time in Japan is ahead of the Greenwich Mean Time by 9 hours. In this case, enter "900."

3.8 Inserting and Ejecting the External Storage Medium

This section explains how to insert and eject the external storage medium. You can use one of three types of external storage medium: floppy disk, Zip disk, or ATA flash memory card. The type of external storage medium is specified at the time of purchase.

CAUTION

- If you turn ON/OFF the CX2000 while a Zip disk is inserted in the drive, the Zip drive may malfunction. When turning ON/OFF the CX2000, first remove the Zip disk from the drive.
- Do not eject the external storage medium while the access lamp is illuminated. This can damage the data.
- Do not operate the floppy disk drive or Zip drive in a place with vibrations or shock. The disk or drive may malfunction.

For other information regarding the handling of the external storage medium, see *section 2.1, "Handling Precautions."*

Procedure

Inserting the External Storage Medium

1. Open the front cover by pressing down on the knob that is located in the center of the upper section of the cover and pulling it forward. Insert the external storage medium into the drive and press it until it clicks into place.

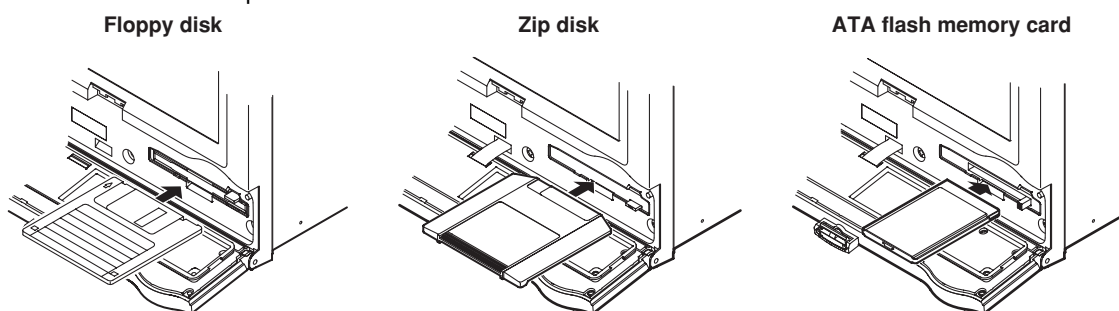

2. When the power switch is turned ON, closing the front cover causes the CX2000 to search for an external storage medium in the drive. If the external storage medium is detected, an icon indicating the existence of the external storage medium appears in the status display section of the display.

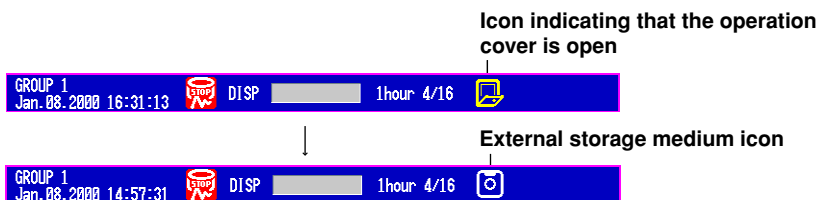

Note

Keep the operation cover closed at all times during operation except when inserting or ejecting the external storage medium. The operation cover protects the external storage medium and the drive from foreign particles such as dust.

3.8 Inserting and Ejecting the External Storage Medium

Ejecting the External Storage Medium

Zip disks cannot be removed when the CX2000 is turned OFF. Floppy disks and ATA flash memory cards can be removed from the drive regardless of whether the CX2000 is turned ON or OFF.

1. If the CX2000 is turned ON, check that the external storage medium is not being accessed.

Note

- The access lamp illuminates while the external storage medium is being accessed.
- If the data in the internal memory is being saved to the external storage medium, the message "Data are being saved to the medium" appears.

2. Open the front cover by pressing down on the knob that is located in the center of the upper section of the cover and pulling it forward.
3. Press the eject button and remove the external storage medium.
4. Close the operation cover.

If the CX2000 is turned ON, the external storage medium icon in the status display section disappears.

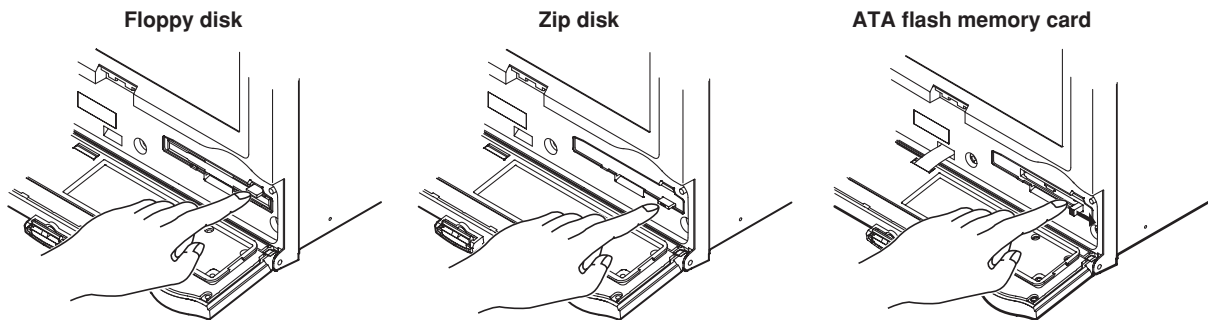

Note

If you are using a Zip disk and the ejection of the Zip disk is prohibited by the key lock function, you cannot eject the Zip disk using the eject button. Clear the key lock before removing the Zip disk. For the procedure in clearing the key lock, see *section 11.2, "Key Lock."*

Procedure When the Zip Disk Cannot Be Ejected

If the Zip disk cannot be removed by performing the steps given in "Ejecting the External Storage Medium," carry out the following steps to eject it.

1. Open the front cover by pressing down on the knob that is located in the center of the upper section of the cover and pulling it forward.
2. Insert a pin with a diameter of around 1 mm into the eject button hole and slowly press the pin in.

The Zip disk will be ejected.

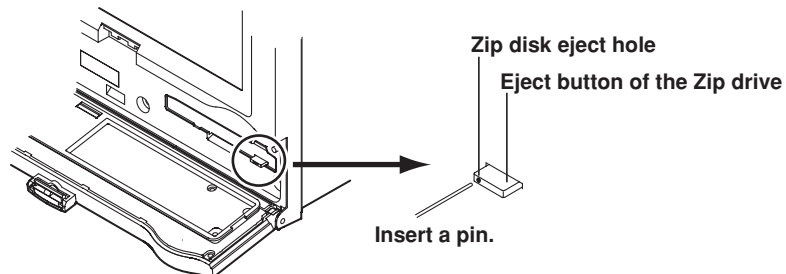

Setup Items

Formatting the External Storage Medium

Use a formatted external storage medium.

The CX2000 formats external storage media as follows (for the procedure in formatting the external storage medium, see *page 9-11*).

Floppy disk: 2HD, 1.44 MB.

Zip disk: FDISK 1 partition (hard disk format).

ATA flash memory card: FDISK 1 partition (hard disk format).

External storage media that are formatted using other instruments can be used on the CX2000, if the format is the same. External storage media of formats other than those listed above cannot be used.

4.1 Control > Control action, Input setting

This section explains the procedures for setting control operation related parameters such as control cycle, zone PID selection, and control mode as well as the procedures for setting PV input burnout and reference junction compensation.

Procedure

Opening the Setting Display

Press the keys in the following sequence:

MENU key (switch to Set mode) > **Hold down the FUNC key for 3 seconds** (switch to basic setting mode) > **#10 soft key** (select [Control]) **#1 soft key** (select [Control action, Input setting])

The following setting display appears (When PV/SP computation is OFF).

Setup Procedure

1. Use the **arrow keys** to move the cursor (blue) to the item box you wish to change. A soft key menu is displayed at the bottom of the display.
2. Press the **soft key** corresponding to the value you wish to select. The box for the item you changed turns yellow, and the cursor moves to the next item.
3. Repeat steps 1 and 2 to change the value of all the items you wish to change.

Note

The reference junction compensation voltage is set using the pop-up window that appears by pressing the [Input] soft key.

4. Press the **DISP/ENTER key** to confirm the changes. The boxes for the items you changed turn from yellow to white, and the cursor returns to the first item box.

Saving the Settings

1. Press the **ESC key**. The display returns to basic setting menu.
2. Press the **[End] soft key**. A confirmation dialog box appears.
3. Select [Yes] and press the **DISP/ENTER key**. The operation screen is displayed.

If you change any of the parameters [PID number], [Control period], [6/4loop select], [Control mode], or [Program control], a message "Initialize setting data" appears in the confirmation window. When you press the DISP/ENTER key, setup items of [Setting mode (Control)] related to these settings (see Note on *page 4-3*) will be initialized.

Setup Items

Setting Control Action Related Parameters

- **PID number**

Set the maximum control parameter group number to be used in the range of [1] to [8] (initial value is 8).
- **Control period**

Select the control cycle from [250ms], [500ms], and [1s] (initial value is 250ms). However, if basic setting mode > [#1 Alarm, A/D, Temperature] > [A/D Integrate] in basic setting mode is set to [100ms], the control period is fixed to [1s] and is not selectable.
- **Zone PID**

Set the PID selection method by turning [Off]/[On] the Zone PID.

Off (initial value): Target setpoint selection
If program control is ON on models with the program control option, this becomes “segment PID.”

On: Zone PID
For the procedure in setting the reference point of the zone PID, see *section 4.8, “Operation-related parameters/Zone PID.”*
- **Restart mode**

Select the action of the fixed-point control loop after recovering from an extended power failure from [Continue], [Manual], [Auto] (initial value is Continue).

Continue: Continue the operation before the power failure occurred.

Manual: Start from a manual operation condition (control output is set to preset output).

Auto: Start from an auto operation condition (start the control output from preset output and resume control computation based on the preset output).
- **Restart mode (Program)** ← Only on models with the program control option
Select the restart mode (recovery behavior) the CX2000 will enter when recovering from a power failure when program operation is performed. Select [Continue], [Manual], or [Reset] (initial value is Continue).

Continue: Continue the operation before the power failure occurred.

Manual: Start from a manual operation condition (control output is set to preset output).

Reset: Start program operation from a reset condition (control output is set to preset output).
- **Initial PID**

Select [Temp] or [Press+Flow] (initial value is Temp) for the initial value of the PID constant (see *page 4-24*). Below are the initial values of PID constants. The PID constant is also initialized to the following value when [Initial PID] is changed.

Initial values for temperature: P = 5.0%, I = 240 s, and D = 60 s.

Initial values for pressure flow: P = 120.0%, I = 20 s, and D = 0 s.
- **6/4 loop select** (set only on 6-loop models)

Select [6loop] or [4loop] (initial value is 6loop) for the number of loops used.
- **Auto tuning**

Select [On] (initial value is Off) to enable the auto-tuning function of the PID constant.
- **Loop number**

The [Control mode], [Program control], and [PID control mode] parameters are set for each loop. When changing these parameters, this setting is used to select the target loop number [1] to [6] (initial value is 1). The loop number is displayed up to the number of loops you specified at the time of purchase.
- **Control mode**

Select a control mode of [Single], [Cascade], [PVSwitching] (initial value is Single), or [Retrans] (Style Number S3 or later). Select [Off] for the loops that are not to be controlled. Different control modes (except for [Retrans]) cannot be specified on the two loops within the single control output terminal block. If you specify [Cascade], both loops are set to [Cascade]. You cannot select [Cascade] or [PVSwitching] for loop [5] or [6].

- **Method** (set only when the control mode is set to [PVSwitching])
Select the switching condition of the two PV inputs from [Range], [PVHigh], and [Signal].
- **Program control** (set only on models with the program control option)
Turns [On]/[Off] program control (initial value is Off). This setting applies to both loops within the single control output terminal block. This setting is invalid for loops which the control mode is set to [Off] or [Retrans].
- **PID control mode**
Select either [Follow-up] or [Fixed-point]. This setting is invalid for loops whose control mode is set to [Off] or [Retrans].

Setting Input-Related Parameters

The setting menu differs when the PV/SP computation function is ON or OFF.

- **Loop number (first and last channel when the PV/SP computation function is ON)**
Set the [Burnout] and [RJC] parameters for each loop. When changing these parameters, this setting is used to select the target loop number [1] to [6] (initial value is 1). The loop number is displayed up to the number of loops you specified at the time of purchase.

When the PV/SP computation function is ON, you can set the control input channel number.

- **Burnout**
Sets the burnout action for the PV inputs of each loop. [Measure2] is valid only when the control mode is set to [PVSwitching]; [Remote] is valid only when the PV input is set to remote input. This setting is invalid for PV inputs other than thermocouples and standard signals.

- **Measure1/Measure2/Remote**

Select [Off], [Up], or [Down] (initial value is Up) according to the description given below.

Off: Burnout action Off

Up: When a burnout occurs, the measured result is set to positive overrange
“+*****”

Down: When a burnout occurs, the measured result is set to negative overrange
“-*****”

When the PV/SP computation function is ON, you can turn the buffer for the control input channel ON or OFF. When ON, the measured results are fixed according to the settings in PV/SP computation error. For information about PV/SP computation error see *section 4.16, “PV/SP Computation and Analog Retransmission Settings (Style Number S3).”*

- **RJC**

This is the reference junction compensation setting for thermocouple inputs. The setting is entered on the PV inputs of each loop. [Measure2] is valid only when the control mode is set to [PVSwitching]; [Remote] is valid only when the PV input is set to remote input. This setting is invalid for PV inputs other than thermocouples.

- **Measure1/Measure2/Remote**

Select either [Internal] or [External] (initial value is Internal).

Internal: Uses the reference junction compensation function of the CX2000.

External: Uses an external reference junction compensation function.

If set to [External], a box for entering the reference junction compensation voltage that is added to the input appears. Set the value in the range of [−20000] μV to [20000] μV (initial value is 0 μV).

When the PV/SP computation function is ON, you can select Internal or External (default value is Internal) for the control input channel. If set to External, a setting box for the reference junction compensation voltage that is added to the input is displayed. The setting range is −20000 μV to 20000 μV (default value is 0 μV).

4.1 Control > Control action, Input setting

Contents Initialized during Setting Changes

If you change the PID group number, 6/4 loop select, or control mode setting, the following items under setting mode (control) are initialized.

PID number

The following items are initialized.

- Segment PID group number

6/4 loop select

Items other than the following are initialized.

- Tag, tag comment
- [#8 Detailed (DIO monitor and operation, etc...) > [#4 DI/DO label setting]
- [#9 Control math setting] > [#3 Constant]

[Control mode]

Items other than the following are initialized.

- Tag, tag comment
- [#5 Control group setting]
- [#8 Detailed (DIO monitor and operation, etc...) > [#3 DI/DO monitor and operation setting]
- [#8 Detailed (DIO monitor and operation, etc...) > [#4 DI/DO label setting]
- [#9 Control math setting] > [#2 Logic math]
- [#9 Control math setting] > [#3 Constant]

4.2 Control > DI/DO/SW-registration/AUX (Alarm mode...)

This section explains the procedures for registering the contact input information during control, selecting remote inputs, and setting the alarm mode.

Procedure

Opening the Setting Display

Press the keys in the following sequence:

MENU key (switch to Set mode) > **Hold down the FUNC key for 3 seconds** (switch to basic setting mode) > **#10 soft key** (select [Control]) > **#2 soft key** (select [DI/DO/SW-registration/AUX (Alarm mode...)])

The following setting display appears.

The screenshot shows the 'Setup Mode' interface. At the top, it says 'Setup Mode' and 'Ethernet Link'. Below that, the title is 'Control <DI/DO/SW-registration.AUX(Alarm mode...)>'. The main area is divided into two sections. The left section is titled 'DI/DO/SW-registration' and contains a table with 'Module' and 'DI001' through 'DI006'. The 'Module' is currently 'CTRL1-DI'. The right section is titled 'AUX' and contains several settings: 'Loop number' (1), 'Remote settings' (Off), 'Alarm mode' (ALWAYS), 'SP No. selection source' (Loop number 1-6: On, Off, Off, Off, Off, Off), 'PU/SP math' (On), 'CLOG error' (Error), and 'Event output settings' (Separate). At the bottom, there are navigation buttons: CTRL1-DI, CTRL2-DI, CTRL3-DI, CTRL1-DO, CTRL2-DO, CTRL3-DO, and Next 1/2.

Setup Procedure

1. Use the **arrow keys** to move the cursor (blue) to the item box you wish to change. A soft key menu is displayed at the bottom of the display.
2. Press the **soft key** corresponding to the value you wish to select. The box for the item you changed turns yellow, and the cursor moves to the next item.
3. Repeat steps 1 and 2 to change the value of all the items you wish to change.
4. Press the **DISP/ENTER key** to confirm the changes. The boxes for the items you changed turn from yellow to white, and the cursor returns to the first item box.

Saving the Settings

1. Press the **ESC key**. The display returns to basic setting menu.
2. Press the **[End] soft key**. A confirmation dialog box appears.
3. Select [Yes] and press the **DISP/ENTER key**. The operation screen is displayed.

Setup Items

Registering Contact Inputs• **Module**

Select the terminal block for contact input settings from the list below. The contact input number in the Relay Operation settings field will change per the selected terminal block.

CTRL1-DI (control output terminal block 1): DI001–DI006

CTRL2-DI (control output terminal block 2): DI101–DI106

CTRL3-DI (control output terminal block 3): DI201–DI206

CTRL1-DO (control output terminal block 1): DO101-DO106

CTRL2-DO (control output terminal block 2): DO201-DO206

CTRL3-DO (control output terminal block 3): DO301-DO306

EXT1-RI (control expansion DIO terminal block 1): RI001–DI012

EXT1-RO (control expansion DIO terminal block 1): RO001-RO012

INT-SW1 (internal switch): SW01-SW12

INT-SW2 (internal switch): SW13-SW24

INT-SW3 (internal switch): SW25-SW36

For a description on the terminal arrangement, see *page 2-6 to 2-7*.

• **Contact input information registration**

Select the contact input information for each contact input registration number from the following. For a description on the method of detecting contact inputs, see *page 1-24*.

• AllControlStop

Select this when registering as a contact input for stopping the control operation of all internal loops.

• AllControlStart

Select this when registering as a contact input for starting the control operation of all internal loops.

• ControlStart/Stop (1 to 6)

Select this when registering a contact input for starting the control operation of each internal loop. The rising edge of the signal signifies “Stop”; the falling edge of the signal signifies “Run.”

For a control output terminal block, up to two loops that can output signals can be registered per block. In the cascade mode, registration is allowed only for loops 2 and 4.

• Remote/Local (1 to 6)

Select this when registering a contact input for switching remote operation and local operation for each internal loop. The rising edge of the signal signifies “Remote”; the falling edge of the signal signifies “Local.”

If program control is ON (only on models with the program control option), switching is performed between program operation and local operation. Remote/Local (loop 1) or (loop 3) is selectable only when program control is ON.

For a control output terminal block, up to two loops that can output signals can be registered per block. In the cascade mode, registration is allowed only for loops 1 and 3.

• Auto/Man (1 to 6) ← not selectable during cascade control

Select this when registering a contact input for switching auto and manual (Man) operation for each internal loop. The rising edge of the signal signifies “Auto”; the falling edge of the signal signifies “Man.”

For a control output terminal block, up to two loops that can output signals can be registered per block.

• Cascade (1-2 or 3-4) ← selectable only during cascade control.

Select this for internal loops 1-2 or 3-4 when registering a contact input for switching from auto operation or manual operation to cascade operation.

Note

[Cascade1-2] or [Cascade3-4] does not appear as a selection, if the [Control mode] box under [Control] > [#1 Control action, Input setting] is not set to [Cascade].

- Auto1-2 or 3-4 ← selectable only during cascade control.
Select this for internal loops 1-2 or 3-4 when registering a contact input for switching from cascade operation or manual operation to auto operation.
- Man1-2 or 3-4 ← selectable only during cascade control.
Select this for internal loops 1-2 or 3-4 when registering a contact input for switching from cascade operation or auto operation to manual operation. A single registration is possible per control output terminal block. This setting is not allowed for control output terminal block 3.
- SPNumber0 to 3 bit
Select when registering a contact input for switching the SP. Four contact inputs (4-bit binary) are used to specify SP numbers [1] to [8]. For example, set SPnumber1bit and SPnumber2bit to ON to specify SP number [6].
Contact outputs that can be registered to [SPnumber0bit] to [SPnumber3bit] are [DI003 to DI006] of loop 1 and 2 control output terminal block and [RI009 to RI012] of the control DIO expansion terminal block. Only the required number of bits can be registered. For example, if you are switching among SP numbers [1] to [3], register only [SPnumber0bit] and [SPnumber1bit] (2 bits).
If [SPnumber0bit] through [SPnumber3bit] that corresponds to the MSB is set to [DI006] of loop 1 and 2 control output terminal block or [RI012] of the control DIO expansion terminal block, the required number of bits of contact inputs—[DI003 to DI006] for the control output terminal block, [RI009 to RI012] for the control DIO expansion terminal block—are automatically registered.

Note

- For contact inputs [SPnumber0bit] to [SPnumber3bit], the loop number for which the SP number is to be switched can be selected. For the operating procedure, see the explanation for [SP No. selection source] on *page 4-8*.
- Only a single system of SP assignment using contact inputs is available on each CX2000.

- ProgramRun ← selectable only during program control
Select to register a contact input for starting the program operation.
- ProgramReset ← selectable only during program control
Select to register a contact input for resetting the program operation.
- Hold ← selectable only during program control
Select to register a contact input for holding the program operation.
- Advance ← selectable only during program control
Select to register a contact input for advancing the program operation.
- PatternNo0 to 4bit ← selectable only during program control
When registering as a contact input for switching the program pattern.

When specifying program pattern numbers in binary

5 contact inputs (5-bit binary) are used to specify the pattern number (1 to 30). For example, set [PatternNo1bit] and [PatternNo2bit] to ON to specify pattern number [6]. Contact outputs that can be registered to [PatternNo0bit] to [PatternNo4bit] are [DI001 to DI005] and [DI201 to DI205] of the control output terminal block and [RI001 to RI005] of the control DIO expansion terminal block. Only the required number of bits can be registered. For example, if only 2 bits are needed to make the switch, register only [PatternNo0bit] and [PatternNo1bit].

If you place the cursor on [DI001] (with the control output terminal block) or [RI001] (with the control DIO expansion terminal block) and press the soft key that includes the maximum pattern number to be specified, contact inputs of the required number of bits, [DI001]-[DI005] (control output terminal block) or [RI001]-[RI005] (control DIO expansion terminal block), are automatically registered.

When specifying program pattern numbers in binary-coded decimal (BCD) (version 3.20 or later)

For the setting procedure, see section 4.19, “Settings for Switching the Program Patterns Using Contact Inputs with BCD Codes (Version 3.20 or Later).”

4.2 Control > DI/DO/SW-registration/AUX (Alarm mode...)

- PVSwitching1 to 4 ← Selectable only during loop control with PV switching
Select to register a contact input for switching the input for each internal loop during loop control with PV switching. This is not selectable for internal loops 5 and 6.
The rising edge signifies “PV2”; the falling edge signifies “PV1.”

Note

[PVSwitching1] or [PVSwitching2] does not appear as a selection, if the [Control mode] box under [Control] > [#1 Control action, Input setting] is not set to [PVSwitching].

- MemoryStart/Stop
Starts/stops the acquisition of the display data/event data to the internal memory and the report function (computation option function). The rising edge of the signal indicates start; the falling edge indicates stop.
If data acquisition is started, applying a rising signal produces no effect. Likewise, if data acquisition is stopped, applying a falling signal produces no effect.
- Trigger
Acts as an external trigger used to start the acquisition of event data to the internal memory when in trigger mode or rotate mode. Input a signal for at least 250 ms.
- AlarmACK
Clears the alarm indication and relay output. This is the same function as when the [AlarmACK] soft key is pressed. Input a signal for at least 250 ms.
- TimeAdjust
Adjusts the internal clock of the CX2000 to the nearest hour depending on the time when the remote signal is applied. Input a signal for at least 250 ms.
Time the signal is input Time modification
00 min 00 s to 01 min to 59 s Truncates the minutes and seconds.
Example: 10 hours 01 min 50 s becomes 10 hours 00 min 00 s.
02 min 00 s to 57 min to 59 s The time is not changed.
58 min 00 s to 59 min to 59 s Rounds up the minutes and seconds.
Example: 10 hours 59 min 50 s becomes 11 hours 00 min 00 s.
- MathStart/Stop
Starts/stops the computation. The rising edge of the signal indicates start; the falling edge indicates stop. This is valid only on models with the computation function option (/M1).
- MathReset
Resets the data on all computation channels. Input a signal for at least 250 ms. This is valid only on models with the computation function option (/M1) and while the computation is stopped.
- ManualSample
Write the instantaneous values of all channels to the internal memory once. Input a signal for at least 250 ms. This excludes measurement channels set to skip and computation channels set to Off.
- Panel1Load to Panel3Load
Loads the setup data file named [LOAD1.PCL], [LOAD2.PCL], or [LOAD3.PCL] stored on the external storage medium and activates the settings. Input a signal for at least 250 ms. Setup data files named [LOAD1.PCL], [LOAD2.PCL], or [LOAD3.PCL] must be created and saved to the external storage medium beforehand.
- Message1 to 8
Displays a message at the position corresponding to the time when the signal was applied on the trend display. The displayed message is also written to the internal memory. Input a signal for at least 250 ms.

- **Snapshot**
Saves the current screen image data to the external storage medium. Input a signal for at least 250 ms.
The snapshot function operates in all modes (operation mode, setting mode, and basic setting mode). Error messages, even if they are displayed, are not saved.

Note

- On models with the /A6R or /A4FR measurement alarm option terminal block, the action from [MemoryStart/Stop] to [Snapshot] can also be assigned to the measurement remote input. For the procedure in assigning actions to the measurement remote input, see *section 11.5, "Measurement Remote Input Setting."*
- If you wish to carry out operation only using contact input, you can disable key operation such as by using the key lock function (see *section 11.2*)

Remote setting, Alarm mode, and SP No. selection source• **Loop number**

The [Remote setting] and [Alarm mode] parameters are set for each loop. When changing these parameters, this setting is used to select the target loop number [1] to [6] (initial value is 1). The loop number is displayed up to the number of loops you specified at the time of purchase.

• **Remote setting** ← only when program control is OFF

Select [Remote] (initial value is Off) to set the PV input to remote input. If [Control mode] is set to [Cascade], this box is not displayed for the loop number of the secondary loop.

• **Alarm mode**

Select the condition for disabling the control alarm from the following. The characters inside the parentheses are character strings displayed as selections in the soft key menu.

ALWAYS: Enable the alarm at all times.

STOP: Disable the alarm when the operation is stopped.

STOP/MAN: Disable the alarm during manual operation mode or when the operation is stopped.

• **SP No. selection source**

Set the loop for switching the SP number using contact inputs [SPnumber0bit] to [SPnumber3bit] (see *section 1.5*). To apply the setting, select [On] (initial value is Off) for each loop number [1] to [6].

• **PV/SP Computation Function**

This setting determines whether or not the computed result is used for PV/SP. When set to ON, you can specify an equation in the control setting mode to use for PV/SP. When the PV/SP computation function is ON, the following settings become active for each control input channel.

- Control input channel range settings
- Ten segment linearizer approximation settings
- External RJC/burnout
If you change the PV/SP computation function, all but the following items under setting mode (control) are initialized.
- Tag, tag comment
- [#5 Control group setting]
- [#8 Detailed (DIO monitor and operation, etc...) > [#3 DI/DO monitor and operation setting]
- [#8 Detailed (DIO monitor and operation, etc...) > [#4 DI/DO label setting]
- [#9 Control math setting] > [#2 Logic math]
- [#9 Control math setting] > [#3 Constant]
- Settings for loops set for analog retransmission

- **CLOG Error**

You can set the method for handling abnormalities in the channel data for CLOG, a PV/SP computation operator.

Error: Process as a computation error

Skip: Skip any abnormal data and complete the computation

- **Event output setting (Version 3.02 or later)**

Common: Set a common event output setting for all program patterns.

Separate: Set the event output for each program pattern.

4.3 Control > Output processing

This section describes the procedures for selecting the control output type, cycle time, and analog output. To perform ON/OFF control, set [Control output] to [On/Off-control].

Procedure

Opening the Setting Display

Press the keys in the following sequence:

MENU key (switch to Set mode) > **Hold down the FUNC key for 3 seconds** (switch to basic setting mode) > **#10 soft key** (select [Control]) **#3 soft key** (select [Output processing])

The following setting display appears.

Control (Output processing)

Output processing

Loop number 1

Control output	Relay
Cycle time	30 s
Analog-output type	4-20mA

Relay Voltage Current On/Off

Setup Procedure

1. Use the **arrow keys** to move the cursor (blue) to the item box you wish to change. A soft key menu is displayed at the bottom of the display.
2. Press the **soft key** corresponding to the value you wish to select. The box for the item you changed turns yellow, and the cursor moves to the next item.
3. Repeat steps 1 and 2 to change the value of all the items you wish to change.
4. Press the **DISP/ENTER key** to confirm the changes. The boxes for the items you changed turn from yellow to white, and the cursor returns to the first item box.

Note

The [Cycle time] is set using the pop-up window that appears by pressing the [Input] soft key.

Saving the Settings

1. Press the **ESC key**. The display returns to basic setting menu.
2. Press the **[End] soft key**. A confirmation dialog box appears.
3. Select [Yes] and press the **DISP/ENTER key**. The operation screen is displayed.

Setup Items

Setting Parameters Related to Output Processing

- **Loop number**

Setup items of [Control output], [Cycle time] and [Analog-output type] are set for each loop. When changing these parameters, this setting is used to select the target loop number [1] to [6] (initial value is 1). The loop number is displayed up to the number of loops you specified at the time of purchase.

Note

The following item boxes do not appear, if the [Control mode] box under [Control] > [#1 Control action, Input setting] is set to [Cascade].

- **Control output**

Select the type of control output from the following.

- Relay
- Voltage-pulse
- Current-output
- On/Off-control

- **Cycle time**

Set the cycle time (control output cycle) for the time proportional PID in the range of [1] s to [1000] s. This setting is valid only when [Control output] is set to [Relay] or [Voltage-pulse].

- **Analog-output type**

Select the type of output current during current output from below. This setting is valid only when [Control output] is set to [Current-output].
4-20mA, 0-20mA, 20-4mA, and 20-0mA

4.4 Control > Relay

This section explains the procedures for setting the contact output for FAIL, self diagnosis, and display hold.

Procedure

Opening the Setting Display

Press the keys in the following sequence:

MENU key (switch to Set mode) > **Hold down the FUNC key for 3 seconds** (switch to basic setting mode) > **#10 soft key** (select [Control]) **#4 soft key** (select [Relay])
The following setting display appears.

Relay	
Module	CTRL1-2
FAIL	On
Self diagnosis	On

Relay(Action/Behavior)	
D0001	De_energize/Nonhold
D0002	De_energize/Nonhold
D0003	Energize/Nonhold
D0004	Energize/Nonhold
D0005	Energize/Nonhold
D0006	Energize/Nonhold

De/Hold De/Non En/Hold En/Non

Setup Procedure

1. Use the **arrow keys** to move the cursor (blue) to the item box you wish to change. A soft key menu is displayed at the bottom of the display.
2. Press the **soft key** corresponding to the value you wish to select. The box for the item you changed turns yellow, and the cursor moves to the next item.
3. Repeat steps 1 and 2 to change the value of all the items you wish to change.
4. Press the **DISP/ENTER key** to confirm the changes. The boxes for the items you changed turn from yellow to white, and the cursor returns to the first item box.

Saving the Settings

1. Press the **ESC key**. The display returns to basic setting menu.
2. Press the **[End] soft key**. A confirmation dialog box appears
3. Select [Yes] and press the **DISP/ENTER key**. The operation screen is displayed.

Setup Items

Setting Relay-Related Parameters

- **Module**

Select the terminal block for setting the contact output from list shown below. The contact output numbers displayed in the [Relay(Action/Behavior)] area vary depending on the selected terminal block as follows:

CTRL1-2 (control output terminal block 1): DO001 to DO006

CTRL3-4 (control output terminal block 2): DO101 to DO106

CTRL5-6 (control output terminal block 3): DO201 to DO206

EXTDIO (control DIO expansion terminal block): RO001 to RO012

Note

The contact output is output from the terminal indicated as [DIGITAL OUT] on the seal on the front of the terminal cover. For the relationship between the contact output numbers and the [DIGITAL OUT] terminals of each terminal block, see *page 2-6*.

- **FAIL**

This is the setting for the function that outputs a relay contact signal (FAIL signal) when a failure is detected in the CX2000 CPU. When set to [On] (initial setting is Off), "DO001" of control output terminal block 1 is automatically assigned to "de_energize/Nonhold."

Note

For the option terminal block with the FAIL output terminal ("/A4F" or "/A4FR" option), the FAIL signal is output from the FAIL output terminal of the option terminal block regardless of this setting.

- **Self diagnosis**

This is the setting for the function that outputs a relay contact signal when an input burnout, A/D converter failure, or reference junction compensation failure occurs. When set to [On] (initial setting is Off), "DO002" of control output terminal block 1 is automatically assigned to "de_energize/Nonhold."

- **Relay (Action/Behavior)**

Select the relay action type of each contact output from the following:

De_energize/hold, De_energize/Nonhold, Energize/Hold, and Energize/Nonhold

Note

The behavior of the transistor (open-collector) output corresponding to the energize/deenergize setting of the relay action is as follows:

When set to deenergize: Switch from high to low during output

When set to energize: Switch from low to high during output

4.5 Control > Tuning setting

This section explains the procedures for setting the parameters that are adjusted on the tuning display.

Procedure

Opening the Setting Display

Press the keys in the following sequence:

MENU key (switch to Set mode) > **Hold down the FUNC key for 3 seconds** (switch to basic setting mode) > **#10 soft key** (select [Control]) **#5 soft key** (select [Tuning setting])
The following setting display appears.

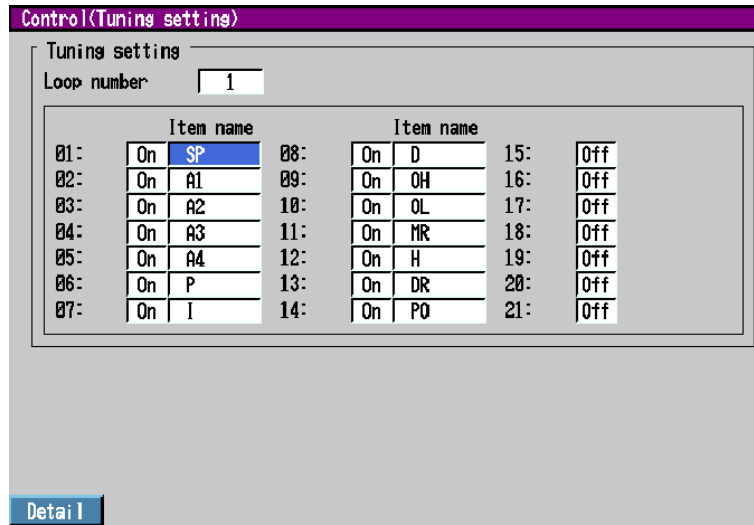

Setup Procedure

1. With the cursor (blue) located at the [Loop number] box, select the loop number for setting the tuning parameter using the **soft keys**.
The selected loop number is displayed in the [Loop number] box, and the cursor moves to the On/Off box of [01:].
2. Using the **arrow keys**, move the cursor to the On/Off box of the tuning parameter you wish to change or the [Item name] box.
The box for the item you changed turns yellow, and the cursor moves to the next item.

Note

The [Item name] is set using the pop-up window that appears by pressing the [Detail] soft key. On the pop-up window, set [Item ID] and [Item name]. Select [Item ID] using the soft key menu. Enter [Item name] by pressing the [Input] soft key and using the character/number input keys.

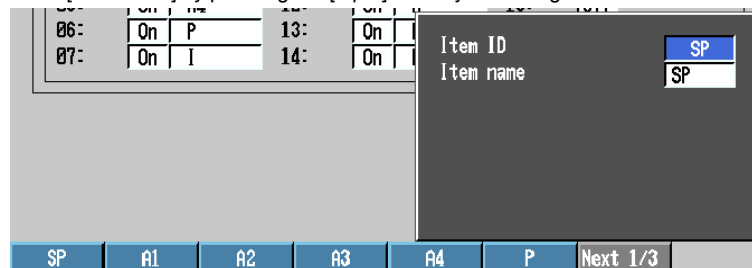

3. Repeat steps 1 and 2 to change the value of all the items you wish to change.

4. Press the **DISP/ENTER key** to confirm the changes.
The boxes for the items you changed turn from yellow to white, and the cursor returns to the first item.

Saving the Settings

1. Press the **ESC key**.
The display returns to basic setting menu.
2. Press the **[End] soft key**.
A confirmation dialog box appears
3. Select [Yes] and press the **DISP/ENTER key**.
The operation screen is displayed.

Setup Items

Setting Tuning Parameters

- **Loop number**

The parameters to be tuned are set for each loop. When changing these parameters, this setting is used to select the target loop number [1] to [6] (initial value is 1). The loop number is displayed for the number of loops you specified at the time of purchase.

- **On/Off**

Set the parameters that are to be displayed on the tuning display to [On]; set the parameters that are not to be displayed to [Off].

- **Item name**

Under the initial settings, the tuning parameters are set as follows. The numbers indicate the order of items on the tuning display starting from the upper left corner. The characters indicate the item names (tuning parameter name). In addition to the tuning parameters below, [DR] (control direction), [H] (relay hysteresis), BS1 (measured value 1 input bias), FL1 (measured value 1 input filter), BS2 (measured value 2 input bias), FL2 (measured value 2 input filter), RT (ratio setting), RBS (remote input bias), RFL (remote input filter), and W01-W36 (control computation constant) are available. BS1-W36 is valid if the main unit is style number S3 or later.

01: SP (target setpoint)	08: D (derivative time)	15: Off
02: A1 (alarm value 1)	09: OH (High limit of the output limiter)	16: Off
03: A2 (alarm value 2)	10: OL (Low limit of the output limiter)	17: Off
04: A3 (alarm value 3)	11: MR (manual reset)	18: Off
05: A4 (alarm value 4)	12: PO (preset output)	19: Off
06: P (proportional band)	13: Off	20: Off
07: I (integral time)	14: Off	21: Off

Select the [Item ID] from the 21 parameters listed above. [Item name] is a name that can be assigned to each parameter. You can use up to 6 alphanumeric characters to specify a name. Under initial settings, [Item name] is set to the same character as the item ID.

Note

- The tuning parameters for external loops using Green series communications are set using [Control] > [#6 External loop setting] > [3# Tuning setting]. External loops have two tuning parameters in addition to those listed above: [DB] and [ETC]. Furthermore, the register address, the upper and lower limits of value range, and the decimal point position can be changed for each tuning parameter in addition to the name.
- BS1, FL1, BS2, FL2, and RFL cannot be selected when the PV/SP computation is ON.

4.6 Control input range

This section explains the procedures for setting PV input related parameters for the control function such as range, span, scale, bias, and filter.

Procedure

Opening the Setting Display

Press the keys in the following sequence:

MENU key (switch to setting mode(control)) > **#1 soft key** (select [Control input range])

The following display appears. The following figure is an example when [Control mode] is set to [Cascade]

Control input range	
Loop number	1
Input type	PV1
Control mode : PV switching control Please set PV range.	
Mode	Scale
Type	TC
Range	R
Span	
Lower-limit	0.0
Upper-limit	1760.0
Scale	
Lower-limit	0.00
Upper-limit	200.00
Unit	
Square root	On
Low-cut	1.0 %
Bias	On
Filter	0.00
	On
	1 s

Setup Procedure

1. Use the **arrow keys** to move the cursor (blue) to the item box you wish to change. A soft key menu is displayed at the bottom of the display.
2. Press the **soft key** corresponding to the value you wish to select. The box for the item you changed turns yellow, and the cursor moves to the next item box.
3. Repeat steps 1 and 2 to change the value of all the items you wish to change.

Note

For setup item boxes that require values to be entered, a pop-up window that appears by pressing the [Input] soft key is used.

4. Press the **DISP/ENTER key**.

A confirmation window appears. If you change any of the parameters besides [Bias] and [Filter], other parameters related to the changed parameter (see Note on the next page) are initialized when you confirm the change. Consequently, a message "Initialize the settings related to range" appears in the confirmation window as shown below.

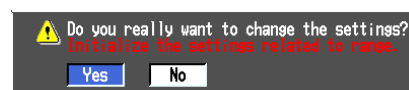

5. Select [Yes] and press the **DISP/ENTER key** and confirm the changes. The boxes for the items you changed turn from yellow to white, and the cursor returns to the first item box.

Setup Items

Setting Control Input Range Parameters

- **Loop number (control input channel when the PV/SP computation function is ON)**
When the PV/SP computation function is OFF, you can set each setting item of the control input range for each loop. When the PV/SP computation function is ON, you can set each setting item of the control input range for each loop. When changing these parameters, this setting is used to select the target loop number [1] to [6] (initial value is 1). The loop number is displayed for the number of loops you specified at the time of purchase.
- **Input type (when PV/SP computation function is OFF)**
Select the target input for making input range related settings from the following.
PV1, PV2, RemoteSP, and PVrange
 - Items [PV2] and [PVrange] appear only when [Control] > [#1 Control action, Input setting] > [Control mode] is set to [PVSwitching]. If the measurement range of the two input signals is different for the loop control with PV switching, make sure to select [PVrange] to determine the PV range.
 - Item [RemoteSP] appears only when [Control] > [#1 Control action, Input setting] > [Program control] is set to [Off] and [Control] > [#2 Contact input-registration/AUX(Alarm mode...)] > [Remote setting] is set to [Remote]. For [PVSwitching], [RemoteSP] is selectable only on odd-numbered loops. In addition, for cascade control, item [RemoteSP] does not appear for the settings of the loop number of the secondary loop.
- **Mode/Type/Range (setting when [Input type] is set to a type other than [PVrange])**
Select the input mode [Mode] from [TC], [RTD], [Scale], and [1-5V]. Then, set other items such as [Range] and [Span Lower/Upper-limit] according to the selected mode.
 - When set to TC (thermocouple)

Range	Selectable Measurement Span Range
R	0.0 to 1760.0 °C
S	0.0 to 1760.0 °C
B	0.0 to 1820.0 °C
K	-200.0 to 1370.0 °C
E	-200.0 to 800.0 °C
J	-200.0 to 1100.0 °C
T	-200.0 to 400.0 °C
N	0.0 to 1300.0 °C
W	0.0 to 2315.0 °C
L	-200.0 to 900.0 °C
U	-200.0 to 400.0 °C
PLATI	0.0 to 1400.0 °C
PR	0.0 to 1900.0 °C
WRe	0.0 to 2400.0 °C

- When set to RTD (resistance temperature detector)

Range	Selectable Measurement Span Range
Pt100	-200.0 to 600.0 °C
JPt100	-200.0 to 550.0 °C

Note

- The CX2000 converts the measured value to a value obtained by removing the decimal point from the value range specified by [Scale Lower] and [Scale Upper]. In other words, if the [Scale] setting is [-5] to [5], the value is converted to a value within the span of "10"; if the [Scale] setting is [-5.0] to [5.0], the value is converted to a value within a span of "100." In this case, the resolution of the value converted to a span of "10" is lower than the value converted to a span of "100."
- If you change any of the parameters [Mode], [Type], [Range], [Span Upper/Lower-limit], [Scale Upper/Lower-limit], or [PV range Lower/Upper-limit], the following setup items (parameters set using engineering units "EU" or "EUS") related to these settings will be initialized. Bias, alarm, SP ramp-down-rate, SP ramp-up-rate, reference point, switching hysteresis, reference deviation, PID parameters, SP, relay hysteresis, ten-segment input, ten-segment output, SP low-limit, SP high-limit, alarm hysteresis, and boundary of partial expanded display.

- When set to Scale

Select the [Type] (input type) from [DCV], [TC], and [RTD]. Then, set the [Range], [Span Lower/Upper-limit], and the [Scale Lower/Upper-limit] and [Unit] after the conversion according to the selected [Type]. The selectable range for [TC] and [RTD] is the same as with the other inputs selected by [Mode]. The selectable range of the scale is “–30000 to 30000.” The decimal place can be set to “X.XXXX,” “XX.XXX,” “XXX.XX,” “XXXX.X,” or “XXXXXX.” The decimal place is determined by the scale low limit setting.

- Range and measurable range for voltage input

Range	Selectable Measurement Span Range
20mV	–20.00 to 20.00 mV
60mV	–60.00 to 60.00 mV
200mV	–200.0 to 200.0 mV
2V	–2.000 to 2.000 V
6V	–6.000 to 6.000 V
20V	–20.00 to 20.00 V
50V	–50.00 to 50.00 V

Note

- Values such as alarm values are set using engineering units (EU or EUS) based on the measurement span. For an explanation on engineering units (EU and EUS), see *appendix 8, “Explanation of Engineering Units (EU and EUS).”*
- For current inputs, a shunt resistor is attached to the input terminal to convert the signal to voltage input. The following table shows the available shunt resistors. For example, a 250-Ω shunt resistor is used to convert the signal to 1 to 5 V for 4-20 mA input.

Name	Model	Resistance
Shunt resistor	4159 20	250 Ω ± 0.1%
(for screw terminals)	4159 21	100 Ω ± 0.1%
	4159 22	10 Ω ± 0.1%

- **PV range Lower/Upper-limit** (setting when [Input type] is set to [PVrange] during loop control with PV switching)
Set the value in the range [–30000] to [30000] (maximum value > minimum value, maximum value – minimum value ≤ 30000).
- **PV switching Lower/Upper limit** (setting when [Input type] is set to [PVrange])
Set the value within the input range. If [Control] > [#1 Control action, Input setting] > [Method] is set to [Range], set [PV switching Upper/Lower]; if [Method] is set to [PVHigh], set [PV switching Upper] only.
- **Scale Lower/Upper-limit**
Set the value in the range [–30000] to [30000] (maximum value > minimum value, maximum value – minimum value ≤ 30000).
- **Unit**
You can enter the unit using up to 6 alphanumeric characters.
- **Square root**
Set whether to perform square root computation on the PV input ([On]/[Off] (initial value)).
- **Low-cut**
Set the low-cut point when the square root computation is On to [0.0 to 5.0]% (initial value is 1.0%).
- **Bias**
Set bias to [On] (initial setting is Off) when adding a constant value (bias) to the PV input. Set the bias value in the EUS range (–100% to 100%) of the measurement span. For example, if the minimum and maximum values of the scale are [10.00] and [200.00], respectively, the selectable range is “–190.00 to 190.00%.” The selectable range is displayed in a pop-up window. Note that the bias can be changed during control operation.

4.6 Control input range

- **Filter**

Turn ON/OFF the input filter and set the time constant when input filter is ON in the range of "1 to 120 s." Note that the time constant of the input filter can be changed during operation.

- **Ratio** (only when [Input type] is set to [RemoteSP])

To multiply a certain ratio to the remote input, set this value to [On] and set the ratio in the range of "0.001 to 9.999." Note that the ratio can be changed during control operation. Note that the ratio can be changed during control operation.

4.7 Control alarm

This section explains the procedures for setting alarms for the control function.

Procedure

Opening the Setting Display

Press the keys in the following sequence:

MENU key (switch to setting mode(control)) > **#2 soft key** (select [Control alarm])

The following display appears.

Type	Standby	Relay Output	Number	Action
On	Off	Off		
On	On	On	D0001	De_energize
Off				
Off				

Alarm value
2000.0
0.0
2000.0
2000.0

Setup Procedure

- Use the **arrow keys** to move the cursor (blue) to the item box you wish to change. A soft key menu is displayed at the bottom of the display.
- Press the **soft key** corresponding to the value you wish to select. The box for the item you changed turns yellow, and the cursor moves to the next item box.
- Repeat steps 1 and 2 to change the value of all the items you wish to change.

Note

For setup item boxes that require values to be entered, a pop-up window that appears by pressing the [Input] soft key is used.

- Press the **DISP/ENTER key** to confirm the changes. The boxes for the items you changed turn from yellow to white, and the cursor returns to the first item box.

Clearing Alarms When They Occur

The following operation is valid only when [Relay Behavior] is set to [Hold] or [Indicator] is set to [Hold].

- In operation mode, press the **FUNC key**. A soft key menu is displayed at the bottom of the display.
- [Press the **[AlarmACK] soft key**.

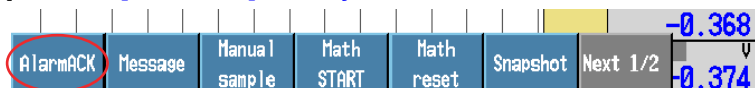

Note

- This operation can be assigned to the USER key. For the procedure in assigning a function to the USER key, see section 11.1, "USER Key Operation."
- This operation is common with measurement alarms.

Setup Items

Setting Control Alarms• **Loop number**

The setup items for control alarms are set for each loop. When changing these parameters, this setting is used to select the target loop number [1] to [6] (initial value is 1). The loop number is displayed up to the number of loops you specified at the time of purchase.

• **Off/On**

Up to four alarms can be registered per loop. Set only the alarms that are to be used to [On].

• **Type**

Select the type of alarm from the following. Displayed symbols are indicated in parentheses. PV high-limit alarm (PVH), PV low-limit alarm (PVL), deviation high-limit alarm (DVH), deviation low-limit alarm (DVL), deviation high & low limit alarm (DVO), deviation within high & low limits alarm (DVI), SP high-limit alarm (SPH), SP low-limit alarm (SPL), output high-limit alarm (OTH), and output low-limit alarm (OTL).

• **Standby**

This setting is valid when [Type] is set to [PV-High], [PV-Low], [Deviation-High], [Deviation-Low], [Deviation-H&L], or [Dev-within-H&L]. Set whether to standby ([On] or [Off]).

• **Relay Output/Number**

Up to four alarms can be registered per control loop. For each alarm, turn ON/OFF the relay output and select the contact output number when using relay output from the list below. For example, [DO001] to [DO006] and [RO001] to [RO012] are available selections of contact output numbers for the control alarm of loop 1.

DO001 to DO006: Loop 1 and 2 control output terminal block

DO101 to DO106: Loop 3 and 4 control output terminal block

DO201 to DO206: Loop 5 and 6 control output terminal block

RO001 to RO012: Control DIO expansion terminal block

SW001 to SW036: Internal switch (Style number S3 or later)

Note

The contact output is output from the terminal indicated as [DIGITAL OUT] on the label on the back of the terminal cover. For the relationship between the contact output numbers and the [DIGITAL OUT] terminals of each terminal block, see *page 2-6*.

• **Action**

Indicates whether the relay output is energized or de-energized according to the [Relay(Action/Behavior)] setting under [Control] > [Relay] (see *page 4-12*).

• **SP number/Alarm value**

The control alarm outputs correspond to SP numbers [1] to [8]. Select the SP number [1] to [8] and register alarm values for the four alarms of each SP number. The selectable alarm values vary depending on the specified [Type] (alarm type) as follows:

PV high/low limits, SP high/low limits: EU of measurement span (0.0 to 100%)

Deviation high/low limits: EUS of measurement span (–100 to 100%)

Deviation high/low limits, within deviation high and low limits: EUS of measurement span (0.0 to 100%)

Output value alarm: –5.0% to 105.0%

Clearing Alarms (AlarmACK)

If the [AlarmACK] operation is performed, all alarm indications and relay outputs are cleared. However, this operation is invalid if the alarm indication/output relay behavior is set to [Nonhold]. Alarms can be cleared using remote input (see *section 11.5, "Setting the Measurement Remote Inputs"*) or via communications (see the *Communication Interface User's Manual*).

4.8 Operation-related parameters/Zone PID

This section explains the procedures for setting the control output suppression function, control operation related parameters such as the ramp-rate-time unit, and zone PID related parameters such as the reference point and zone switching hysteresis.

Procedure

Opening the Setting Display

Press the keys in the following sequence:

MENU key (switch to setting mode(control)) > **#3 soft key** (select [Operation-related parameters/Zone PID])

The following display appears.

Operation-related parameters/Zone PID	
Loop number	1
Suppressing function	Overshoot
Ramp-rate time unit	Hour
SP ramp-down-rate	On
SP ramp-up-rate	On
Tag	INT-01
Tag comment	
Reference point	1 1370.0
	2 1370.0
	3 1370.0
	4 1370.0
	5 1370.0
	6 1370.0
Switching hysteresis	7.8
Reference deviation	On

Setup Procedure

1. Use the **arrow keys** to move the cursor (blue) to the item box you wish to change. A soft key menu is displayed at the bottom of the display.
2. Press the **soft key** corresponding to the value you wish to select. The box for the item you changed turns yellow, and the cursor moves to the next item box.
3. Repeat steps 1 and 2 to change the value of all the items you wish to change.

Note

For setup item boxes that require values to be entered, a pop-up window that appears by pressing the [Input] soft key is used.

4. Press the **DISP/ENTER key** to confirm the changes. The boxes for the items you changed turn from yellow to white, and the cursor returns to the first item box.

Setup Items

Setting Operation-Related Parameters

- **Loop number**

The setup items of "Operation-related parameters" are set for each loop. When changing these parameters, this setting is used to select the target loop number [1] to [6] (initial value is 1). The loop number is displayed up to the number of loops you specified at the time of purchase.

- **Suppressing function**

Select whether to use the overshoot suppressing function, [Overshoot] or [Off]. This function operates only during PID control. However, the function does not operate if the integral time or derivative time or both are set to [0].

- **Ramp-rate time unit**
Set the unit of time when setting a ramp grade per unit time to [Hour], [Minute], or [Second].
- **SP ramp-down-rate/SP ramp-up-rate**
Set this item to [On] (initial setting is Off) to decrease or increase the setpoint at a constant rate of change, as opposed to a rapid change, when the SP is changed. When set to [On], set the value that is to change per ramp-rate-time unit in the range of “1 digit to EUS of measurement span (100%).”
- **Tag/Tag comment**
Set the tag name or tag comment of each control loop using up to 8 alphanumeric characters.

Setting Parameters Related to Zone PID

These settings are possible only when [Zone PID] under [Control] > [#1 Control action, Input setting] is set to [On].

- **Loop number**
The setup items of zone PID method are set for each loop. When changing these parameters, this setting is used to select the target loop number [1] to [6] (initial value is 1). The loop number is displayed up to the number of loops you specified at the time of purchase.
- **Reference point**
Set the reference points for the zone PID method.
The number of reference points that can be specified is “PID group number – 2.”
Reference points can only be specified when [PID number] is set to [3] or higher. For a description on the settings of the number of PID groups, see *section 4.1, “Control > Control action, Input setting.”*
The selectable range of reference point values is shown using “EU (0.0 to 100.0%) of the measurement span) in a pop-up window. Reference points set up to 100% are valid. Set the reference points so that $1 \leq 2 \leq 3 \leq 4 \leq 5 \leq 6$.
- **Switching hysteresis**
Set the hysteresis used for switching zones at the reference points and deviation in the range of “EUS (0.0 to 10.0%) of the measurement span” (initial value is 0.5%).
Can be specified when the [PID number] is set to 2 or greater.
- **Reference deviation**
Set this value to [On] (initial value is Off) when selecting the PID value according to the deviation from the SP (program setpoint). When set to [On], set the deviation in the range of 1 digit to EUS (100.0%) of the measurement span.
Can be specified when the [PID number] is set to 2 or greater.

4.9 PID parameters

This section explains the procedures for setting the PID control parameters of the control function or the control parameters of the ON/OFF control.

Procedure

Opening the Setting Display

Press the keys in the following sequence:

MENU key (switch to setting mode(control)) > **#4 soft key** (select [PID parameters])

The following display appears.

- During PID control

PID parameters			
PID parameters			
Loop number	1		
PID number			
PID number	1		
Target setpoint	-200.0	Reverse/Direct	Reverse
Proportional band(P)	5.0 %	Preset output	0.0 %
Integral time(I)	240 s		
Derivative time(D)	60 s		
Output lower limit	0.0 %		
Output upper limit	100.0 %		
Shutdown	Off		
Manual reset	50.0 %		

- During ON/OFF control (when [Control] > [Output processing] > [Control output] is set to [On/Off-control])

PID parameters			
PID parameters			
Loop number	1		
PID number			
PID number	1		
Target setpoint	-200.0	Reverse/Direct	Reverse
		Preset output	0.0 %
Relay hysteresis			
Value	7.8		
Position	Mid		

Setup Procedure

1. Use the **arrow keys** to move the cursor (blue) to the item box you wish to change. A soft key menu is displayed at the bottom of the display.
2. Press the **soft key** corresponding to the value you wish to select. The box for the item you changed turns yellow, and the cursor moves to the next item box.
3. Repeat steps 1 and 2 to change the value of all the items you wish to change.

Note

For setup item boxes that require values to be entered, a pop-up window that appears by pressing the [Input] soft key is used.

Setup Items

4. Press the **DISP/ENTER** key to confirm the changes.
The boxes for the items you changed turn from yellow to white, and the cursor returns to the first item box.

Setting PID Parameters

- **Loop number**

The setup items of PID parameters are set for each loop. When changing these parameters, this setting is used to select the target loop number [1] to [6] (initial value is 1). The loop number is displayed for the number of loops you specified at the time of purchase.

Note

Some of the following parameter boxes do not appear, if [Control] > [#1 Control action, Input setting] > [Control mode] is set to [Cascade].

- **PID number**

Specify the PID parameter group number [1] to [8]. The maximum selectable number conforms to the [Control] > [#1 Control action, Input setting] > [PID number] setting.

- **Target setpoint**

Set the target setpoint (SP) in the range of “0 to 100% (EU (0 to 100%)) of the measurement span” (initial value is 0%). However, this value is set within the high and low limits of the target setpoint limiter.

- **Proportional band (P)**

Set the proportional band in the range of [0.1] to [999.9]% (initial value for [Temp] is 5.0%; initial value for [Press+Flow] is 12.0%).

- **Integral time (I)**

Set the integral time in the range of [0] to [6000] s (initial value for [Temp] is 240 s; initial value for [Press+Flow] is 20 s).

- **Derivative time (D)**

Set the derivative time in the range of [0] to [6000] s (initial value for [Temp] is 60 s; initial value for [Press+Flow] is 0 s).

- **Output lower/upper limit**

Set the low and high limits of the control output operation range in the range of [–5.0]% to [105.0]% (where high limit > low limit). The initial low limit value is [0.0]%; the initial high limit value is [100.0]%.

- **Shutdown** ← set only during 4-20 mA current output

When [Control] > [Output processing] > [Control output] is set to [Current-output] and [Analog-output type] is set to [4-20mA] (see page 4-10), set whether the shutdown function is used ([On] (initial value) or [Off]).

- **Manual reset**

For the manual reset value, set the output value when the PV = the SP in the range of [–5.0] to [105.0]% (initial value is 50%). This setting is valid only when the integral action (integral time) is set to Off.

- **Relay hysteresis** ← can be set only during ON/OFF control

Set the hysteresis of the SP (or program setpoint) for ON/OFF control in the range of “EUS (0.0 to 100.0%) of the measurement span” (initial value is 0.5%). Then, set the activation position of the hysteresis to [Mid], [High], or [Low] (initial setting is Mid).

- **Reverse/Direct**

Set the direction (increase or decrease) of the output corresponding to the polarity of the deviation to [Reverse] (initial setting) or [Direct].

- **Preset output**

Set the fixed-point output value when the operation is stopped in the range of “–5.0 to 105.0%” (initial setting is 0.0%).

4.10 Control group setting

This section explains the procedures for setting groups for the control function.

Procedure

Opening the Setting Display

Press the keys in the following sequence:

MENU key (switch to setting mode(control)) > **#5 soft key** (select [Control group setting])

The following display appears.

	Kind	Number	Tag	Tag comment
1	On	Int-Loop 01	INT-01	
2	On	Int-Loop 02	INT-02	
3	On	Int-Loop 03	INT-03	
4	On	Int-Loop 04	INT-04	
5	On	Int-Loop 05	INT-05	
6	On	Int-Loop 06	INT-06	

Setup Procedure

1. Use the **arrow keys** to move the cursor (blue) to the item box you wish to change. A soft key menu is displayed at the bottom of the display.
2. Press the **soft key** corresponding to the value you wish to select. The box for the item you changed turns yellow, and the cursor moves to the next item box.
3. Repeat steps 1 and 2 to change the value of all the items you wish to change.
4. Press the **DISP/ENTER key** to confirm the changes. The boxes for the items you changed turn from yellow to white, and the cursor returns to the first item box.

Setup Items

Control group setting

- **Group number**
Select the group number form 8 group numbers from [1] to [8].
- **Group name**
Set the group name using up to 16 alphanumeric characters.

Group name display example

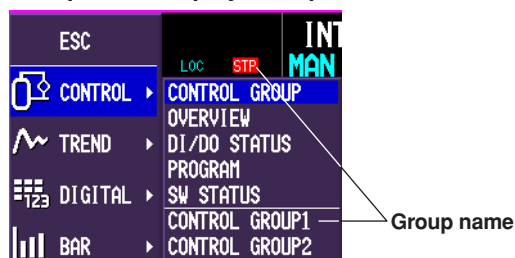

4.10 Control group setting

- **On/Off**

Up to 6 members [1] to [6] can be assigned to a group. Set members that are not to be displayed on the control group display to [Off].

- **Kind**

Set the type of member to [Int-Loop], [Ext-Loop], [Meas-CH], or [DIO] (DIO monitor and operation function).

- **Number**

Select a number for each type set to the members. The selectable numbers are displayed on the soft key menu according to the specifications of the CX2000 that you are using.

Internal loop: 01 to 06

External loop: 01 to 16

Measurement channel: 01 to 20

DIO: 01 to 36

4.11 Ten-segment linearizer I/O

This section explains the procedures for setting parameters related to the ten-segment linearizer output for the control function.

Procedure

Opening the Setting Display

Press the keys in the following sequence:

MENU key (switch to setting mode(control)) > **#6 soft key** (select [Ten-segment linearizer I/O])

The following display appears.

Lineariz					
Loop number	1				
Input type	PV1				
Mode					
Biasing					
Input	Output	Input	Output		
1	5.00	0.50	8	10.00	0.50
2	6.00	0.50	9	10.00	0.50
3	10.00	0.50	10	10.00	0.50
4	10.00	0.50	11	10.00	0.50
5	10.00	0.50			
6	10.00	0.50			
7	10.00	0.50			

Setup Procedure

1. Use the **arrow keys** to move the cursor (blue) to the item box you wish to change. A soft key menu is displayed at the bottom of the display.
2. Press the **soft key** corresponding to the value you wish to select. The box for the item you changed turns yellow, and the cursor moves to the next item box.
3. Repeat steps 1 and 2 to change the value of all the items you wish to change.

Note

For setup item boxes that require values to be entered, a pop-up window that appears by pressing the [Input] soft key is used.

4. Press the **DISP/ENTER key** to confirm the changes. The boxes for the items you changed turn from yellow to white, and the cursor returns to the first item box.

Setup Items

Ten-segment linearizer I/O

- **Loop number (control input channel number when the PV/SP computation function is ON)**

The setup items of ten-segment linearizer output parameters are set for each loop. When the PV/SP computation function is ON, you can set each setting item of the ten-segment linearizer I/O settings for each control input channel. When changing these parameters, this setting is used to select the target loop number [1] to [6] (initial value is 1). The loop number is displayed up to the number of loops or channels you specified at the time of purchase.

- **Input type (when PV/SP computation function is OFF)**

Only during loop control with PV switching, select [PV1] or [PV2]. During single loop control and cascade control, only [PV1] is displayed.

- **Mode**

When using the ten-segment linearizer approximation, set the mode to [Biasing] or [Approximation]. If not, set to [Off] (initial setting).

- **Input/Output**

If you are using the ten-segment linearizer approximation, set between 2 to 11 points of input/output values. If the number of segmental points is less than 11, set the next Input value of the next segmental point to the same value as (or a value less than) the Input value of the final segment.

The selectable range is indicated below.

- For ten-segment linearizer bias

Selectable range of input value: EU (–5.0% to 105.0%) of the measurement span (initial value for points other than the second is 0.0%, initial value for the second point is 100%)

Selectable range of output value: EUS (–100.0% to 100.0%) of the measurement span (initial value is 0.0%)

The selectable range is displayed in a pop-up window.

- For ten-segment linearizer approximation

Selectable range of input value: EU (–5.0% to 105.0%) of the measurement span (initial value for points other than the second is 0.0%, initial value for the second point is 100%)

Selectable range of output value: EU (–5.0% to 105.0%) of the measurement span (initial value is 0.0%)

The selectable range is displayed in a pop-up window.

4.12 Control Function Settings

This section explains the setting procedure for the control function.

Procedure

Opening the Setting Display

Press the keys in the following sequence:

MENU key (switch to setting mode(control)) > **#7 soft key** (select [Detailed setting] (DIO monitor and operation, etc...), **#8 soft key** when program control is ON) > **#1 soft key** (Control function)

The following display appears.

Control function	
Loop number	1
SP tracking	On
PV tracking	On
Target setpoint limiter	
Lower	0.0
Upper	2000.0
Output velocity limiter	On
Anti-reset windup	100.0 %/s
	Manual
	100.0 %

Setup Procedure

1. Use the **arrow keys** to move the cursor (blue) to the item box you wish to change.
A soft key menu is displayed at the bottom of the display.
2. Press the **soft key** corresponding to the value you wish to select.
The box for the item you changed turns yellow, and the cursor moves to the next item box.
3. Repeat steps 1 and 2 to change the value of all the items you wish to change.

Note

For setup item boxes that require values to be entered, a pop-up window that appears by pressing the [Input] soft key is used.

4. Press the **DISP/ENTER key** to confirm the changes.
The boxes for the items you changed turn from yellow to white, and the cursor returns to the first item box.

Setup Item

- **Loop number**

You can enter the setting for each loop. When changing these settings, select a loop to be changed from 1 to 6 (default is 1). Only the number of loops specified at the time of purchase appear in the list.
- **Target Setpoint Tracking**

Select whether to turn the Target Setpoint Tracking function ON (default) or OFF. Operation proceeds as follows when turned ON.

 - **With no program control**

Tracking when switching from remote to local (the local setting value follows the remote setting value).
 - **During program control**

Tracking when switching from program control to local control (the local setting value follows the program setting value).
- **Measured Value Tracking**

Select whether to turn the Measured Value Tracking function ON (default) or OFF. Operation proceeds in the following cases when the function is turned ON. Operates only with local operation during program control.

 - When shifting from manual operation to automatic operation.
 - When starting automatic operation from the operation stop condition.
 - When turning the power ON.
 - When changing the target setpoint number
- **Target Setpoint Lower and Upper Limit**

Set when applying limits to the target setpoint setting range. The setting range is "EU 0.0% to 100.0% of the measurement span" (lower limit < upper limit). The available setting range appears in the pop-up window.
- **Output Velocity Limiter**

You can turn the velocity limiter of the control output ON or OFF (default), and set the rate of change in the range from 0.1% to 100.0%/s.
- **Anti-Reset Windup**

Select whether to activate the anti-reset windup function on Auto or Manual. If you select Manual, select the deviation width of the point at which the PID computation is resumed disengaging from the output saturated status, and the deviation width of points that restart PID computation in the range from 50.0% to 200.0%.

4.13 Hysteresis (Alarm)

This section explains the control function's hysteresis alarm setting procedure.

Procedure

Opening the Setting Display

Press the keys in the following sequence:

MENU key (switch to setting mode(control)) > **#7 soft key** (select [Detailed setting] (DIO monitor and operation, etc...), **#8 soft key** when program control is ON) > **#2 soft key** (Hysteresis (Alarm))

The following display appears.

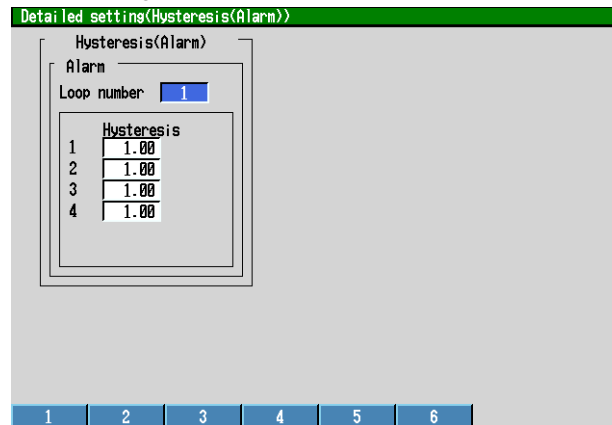

Setup Procedure

1. Use the **arrow keys** to move the cursor (blue) to the item box you wish to change.
A soft key menu is displayed at the bottom of the display.
2. Press the **soft key** corresponding to the value you wish to select.
The box for the item you changed turns yellow, and the cursor moves to the next item box.
3. Repeat steps 1 and 2 to change the value of all the items you wish to change.

Note

For setup item boxes that require values to be entered, a pop-up window that appears by pressing the [Input] soft key is used.

4. Press the **DISP/ENTER key** to confirm the changes.
The boxes for the items you changed turn from yellow to white, and the cursor returns to the first item box.

Setup Item

Hysteresis Settings

- **Alarm**

- **Loop number**

- You can enter the alarm setting for each loop. When changing these settings, select a loop to be changed from 1 to 6 (default is 1). Only the number of loops specified at the time of purchase appear in the list.

- **Hysteresis**

- Set each of 4 alarms in the range of “measurement span of EUS (0.0-10.0%).” However, for the hysteresis for output high limit (OTH) or output low limit (OTL), the output range is set from 0.0 to 10.0%. The available setting range appears in the pop-up window.

4.14 DIO Operation Monitoring Function Settings (Style Number S3 or Later)

This section explains the setting procedure for the control function's DIO operation monitoring function.

Procedure

Opening the Setting Display

Press the keys in the following sequence:

MENU key (switch to setting mode(control)) > **#7 soft key** (select [Detailed setting] (DIO monitor and operation, etc...), **#8 soft key** when program control is ON) > **#3 soft key** (DIO monitor and operation setting)

The following display appears.

DIO monitor and operation settings	
DIO entry number	01
On/Off	On
Kind	DIO-12
SW number	SW001
DO number	DO001
ON	DO004
OFF	DI001
DI number	
Tag	
Tag comment	
Operation property	
ON	Label: ADG
Color	Red
OFF	Label: JHP
Color	Green

01 02 03 04 05 06 Next 1/6

Setup Procedure

1. Use the **arrow keys** to move the cursor (blue) to the item box you wish to change.
A soft key menu is displayed at the bottom of the display.
2. Press the **soft key** corresponding to the value you wish to select.
The box for the item you changed turns yellow, and the cursor moves to the next item box.
3. Repeat steps 1 and 2 to change the value of all the items you wish to change.

Note

For setup item boxes that require values to be entered, a pop-up window that appears by pressing the [Input] soft key is used.

4. Press the **DISP/ENTER key** to confirm the changes.
The boxes for the items you changed turn from yellow to white, and the cursor returns to the first item box.

4.14 DIO Operation Monitoring Function Settings (Style Number S3 or Later)

Setup Item

DIO Operation Monitoring Function Settings

- **DIO Operation Monitoring Number**

You can enter settings for each DIO monitoring number. There are 36 DIO monitoring numbers.

- **DIO Types**

Select the DIO monitoring method. There are 7 types of DIO available.

- DI-1: Displays the input status of the specified DI. The status of the internal switches are output.
- DO-1: The status of the internal switches is output to 1 DO. 1 (ON) is output when the internal switches are ON, and 0 (OFF) is output when they are OFF.
- DO-2: You can output the ON and OFF statuses of the internal switches to separate DOs. 1 (ON) is output from the ON output DO when the internal switches are ON, and 0 (OFF) is output from the OFF output DO when they are OFF. 0 (OFF) is output from the ON output DO when the internal switches are OFF, and 1 (ON) is output from the OFF output DO when they are ON.
- DIO-11: The same operation as the DO-1 is performed while displaying the input status of the specified DI.
- DIO-12: The same operation as the DO-2 is performed while displaying the input status of the specified DI.
- DO-2P: You can output the ON and OFF statuses of the internal switches to separate DOs. A pulse signal having a 1 to 2 second pulse width is output from the ON output DO when the internal switches are ON, and from the 0 (OFF) output DO when they are OFF.
- DIO-12P: The same action as the DO-2P is performed while displaying the input status of the specified DI.

Internal switches		ON	
		OFF	
DO-1/ DIO-11		1 (ON)	
		0 (OFF)	
DO-2/ DIO-12	DO for ON output	1 (ON)	
	DO for OFF output	1 (ON)	
DO-2P/ DIO-12P	DO for ON output	1 (ON)	
	DO for OFF output	0 (OFF)	

- **SW Number**

Set the internal switch for DO output. This is not displayed if DI-1 was selected for the DIO type.

- **DO Number**

Set the DO number to be output. This is not displayed if DI-1 was selected for the DIO type. If DO-2, DIO-12, DO-2P, or DIO-12P is selected for the DIO type, set the DO for when the internal switches are ON and for when they are OFF. Set a different DO number for ON and OFF.

DO numbers may not overlap with other numbers, including DIO operation monitoring numbers.

Note

- This instrument has several functions for outputting contact signals from DO. If output from multiple functions occurs for the same DO, the following priorities apply.
FAIL/self diagnosis output > DIO operation monitoring function > other (alarm output etc.)
 - For the energized/de-energized status of the DO set as the destination of the DIO operation monitoring function, follow the procedure in section 4.4, "Control > Relay."
 - For the hold/nonhold status of the DO set as the destination of DIO operation monitoring function, follow the procedure in section 4.4, "Control > Relay."
-

- **DI Number**

Sets the DI number displayed on the CX screen. This is not displayed if DO-1, DO-2, or DO-2P was selected for the DIO type.

- **Tag and Tag Comment**

Enter a tag and tag comment of the DIO operation monitoring function using 8 characters or less.

- **Operation Status Display**

Set the color and label used when displaying the DO status on the CX screen. You can enter settings for both ON and OFF statuses.

4.15 DI/DO Label Settings (Style Number S3 or Later)

This section explains the control function's DI/DO label setting procedure.

Procedure

Opening the Setting Display

Press the keys in the following sequence:

MENU key (switch to setting mode(control)) > **#7 soft key** (select [Detailed setting] (DIO monitor and operation, etc...), **#8 soft key** when program control is ON) > **#4 soft key** (DI/DO label setting)

The following display appears.

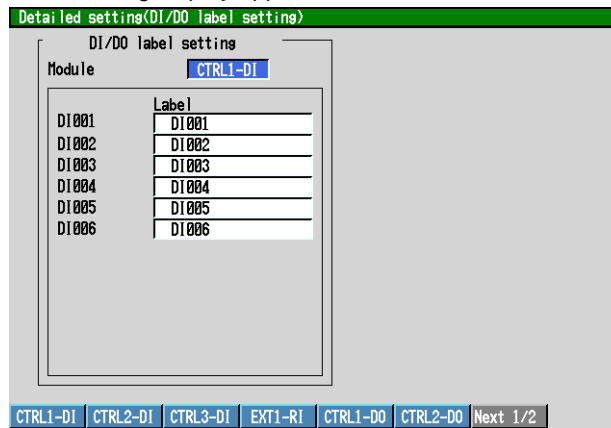

Setup Procedure

1. Use the **arrow keys** to move the cursor (blue) to the item box you wish to change.
A soft key menu is displayed at the bottom of the display.
2. Press the **soft key** corresponding to the value you wish to select.
The box for the item you changed turns yellow, and the cursor moves to the next item box.
3. Repeat steps 1 and 2 to change the value of all the items you wish to change.

Note

For setup item boxes that require values to be entered, a pop-up window that appears by pressing the [Input] soft key is used.

4. Press the **DISP/ENTER key** to confirm the changes.
The boxes for the items you changed turn from yellow to white, and the cursor returns to the first item box.

Setup Item

DI/DO Label Settings

- **Module**
Select the control output terminal block. You can also select the control DIO expansion terminal block.
- **Label**
Enter a label for each terminal using 16 characters or less.

4.16 PV/SP Computation and Analog Retransmission Settings (Style Number S3 or Later)

This section explains the control function's PV/SP computation and analog retransmission setting procedure.

Procedure

Opening the Setting Display

Press the keys in the following sequence:

MENU key (switch to setting mode (control)) > **#8 soft key** (select [Control math setting]), **#9 soft key** when program control is ON) > **#1 soft key** (PV/SP math, Retransmission)

The following display appears.

Setup Procedure

- Use the **arrow keys** to move the cursor (blue) to the item box you wish to change.
A soft key menu is displayed at the bottom of the display.
- Press the **soft key** corresponding to the value you wish to select.
The box for the item you changed turns yellow, and the cursor moves to the next item box.
- Repeat steps 1 and 2 to change the value of all the items you wish to change.

Note

For setup item boxes that require values to be entered, a pop-up window that appears by pressing the [Input] soft key is used.

- Press the **DISP/ENTER key** to confirm the changes.
The boxes for the items you changed turn from yellow to white, and the cursor returns to the first item box.

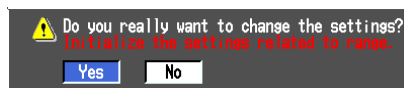

- With Yes selected, press **DISP/ENTER key** to confirm the changed settings.
The item boxes for the changed items turn from yellow to white, and the cursor returns to the top item.

Setup Item

PV/SP Computation Settings

- **Loop number**
Select the loop number to perform PV/SP computation.
- **PV/SP**
Select the item for which to set the equation. The available settings vary depending on the control mode.
Single loop control: PV
2 input switching control: PV1, PV2
Cascade control: PV
SP can be selected when program control is OFF and remote input is ON (see section 4.2, "Control > Contact-input registration/AUX (Alarm mode).")
- **Mode**
Select whether to activate or deactivate PV/SP computation.
If set to OFF, the measured input values of the input terminals on the analog input terminal block for control assigned as default values, are PV.
- **Equation**
Follow the instructions in the equation pop-up window to enter the equation (using 120 characters or less). The number of data that can be used in equations is 35. You can also use the control constants W01-W36 in the equation. Measurement constants K01-K36 cannot be used.
See appendix 3, "Meanings and Syntax of Equations" for information on how to create equations.
When the mode is OFF, the input terminal numbers of the analog input terminal block for control assigned as default values are input.

Control Mode	Single Loop Control		Cascade Control		2 Input Switching Control (4 loops)			2 Input Switching Control (6 loops)		
	PV	SP	PV(1)	SP	PV1	PV2	SP	PV1	PV2	SP
Loop 1	CI01	CI02	CI01	CI02	CI01	CI02	CI03	CI01	CI02	CI01
Loop 2	CI04	CI05	CI04	—	CI04	CI05	CI01	CI04	CI05	CI01
Loop 3	CI06	CI07	CI06	CI07	CI06	CI07	CI08	CI06	CI07	CI01
Loop 4	CI09	CI10	CI09	—	CI09	CI10	CI01	CI09	CI10	CI01
Loop 5	CI03	CI01	—	—	—	—	—	—	—	—
Loop 6	CI08	CI01	—	—	—	—	—	—	—	—

- **PV Range Lower Limit/Upper Limit**
Set in the range -30000 to 30000 (max value > min value, max-min, ≤ 30000).
Settings cannot be changed during control operation, while writing to memory, or during measurement computation.

Note
If you change the PV range upper limit/lower limit value, the range-related setting items below (items set using industrial units EU or EUS) are initialized.
Bias value, alarm value, target setpoint ramp-down, target setpoint ramp-up, reference point, switching hysteresis, reference deviation, PID parameters, target setpoint, relay hysteresis, ten segment linearizer mode, SP low limit, SP high limit, boundary of partial expanded display.

- **Input Switching PV Lower Limit Value/Upper Limit Value (2 input switching control only)**
Set in the range -30000 to 30000 (max value > min value, max. - min., 30000), and within the PV range. When Setting Range is selected under Control Basic Setting > #1 Control operation, settings > Switching condition, and when [Input switching PV upper limit/PV lower limit] and [Switching condition] are [PV upper limit], only [Input switching] is set. [2]
Settings cannot be changed during control operation, while writing to memory, or during measurement computation.

- **Units**
Computed result units are set using 6 characters or less. Settings cannot be changed during control operation.
- **Ratio Settings (only when SP is selected for PV/SP)**
When applying a specific ratio to SP, turn the setting ON, and set the ratio in the range from 0.0001 to 30000. Settings can be changed during control operation, while writing to memory, or even during measurement computation.
- **Remote Bias (Only When SP Is Selected for PV/SP)**
Turn the setting ON to add a constant value (bias value) to SP, and set the bias value within EUS (-100% to 100%). Settings can be changed during control operation, while writing to memory, or even during measurement computation.
- **Computation Error**
Set whether to apply the computed value to the upper limit value (over) or the lower limit value (under) if the computed results in an error.
Over: Use the upper limit value of the PV range for the PV and SP value. [+*****] is displayed. Control operation stops, and preset output occurs.
Under: Use the lower limit value of the PV range for the PV and SP value. [-*****] is displayed. Control operation stops, and preset output occurs.

Note

- Just after the power is turned ON, PV/SP computation may begin before measurement/control channels are finalized. In such cases, the PV/SP computed results are indefinite, and control PID computation is not performed. If the power outage recovery is set to "continuous" and an outage occurs, or an instantaneous outage occurs (5 seconds or less), the previous value is output. If the power outage recovery is set to "manual" or "automatic" and a power outage occurs, the preset value is output.
- If errors occur on the control input channels used in the equation (burnout, AD converter abnormality, reference junction compensation error), failure diagnostics are performed but not output in computation errors.

Analog Retransmission Settings

- **Loop Number**
Select the loop number to perform analog retransmission. This is valid for the loops set for analog retransmission in the control mode of Control Basic Settings.
- **Mode**
Select whether to activate or deactivate analog retransmission computation. When OFF, 0 V or 0 mA are output.

Note

When the mode is OFF, manual operations in operation mode are not available.

- **Equation**
Follow the instructions in the equation pop-up window to enter the equation (using 120 characters or less). The number of data that can be used in equations is 35. You can also use the control constants W01-W36 in the equation. Measurement constants K01-K36 cannot be used.
See *appendix 3, "Meanings and Syntax of Equations"* for information on how to create equations.
- **Upper/Lower Limit of Output Span**
Set in the range -30000 to 30000 (upper limit value > lower limit value, upper - lower 30000). The upper limit value specified here is 100%, the lower limit value is 0%, and the computed results are converted. Converted results are output according to the control output type (see *section 4.3, "Control > Output Processing"*).
- **Units**
Computed result units are set using 6 characters or less.

4.16 PV/SP Computation and Analog Retransmission Settings (Style Number S3 or Later)

- **Computation Error**

Set whether to apply an the computed value to the upper limit value (over) or the lower limit value (under) if the computed results in an error.

Over: 105% of the value is output for an overrange.

Under: -5% of the value is output for an underrange.

Note

- The following values are output when the computed result is overrange or underrange.
Overrange: 105%
Underrange: -5%
 - The following are causes of computation errors.
 - Error in computation (divide by 0 etc.)
 - The equation is used, and a burnout occurs on channels whose burnout is set to ON
 - Trouble occurred with the AD converter on channels using the equation
 - Channels using the equation are set to Skip.
-

4.17 Logic Computation Settings (Style Number S3 or Later)

This section explains the logic computation setting operation.

Procedure

Opening the Setting Display

Press the keys in the following sequence:

MENU key (switch to setting mode(control)) > **#8 soft key** (select [Control math setting]), **#9 soft key** when program control is ON) > **#2 soft key** (Logic math)

The following display appears.

Relay	Calculation expression
1 DO001	CT01.NE.W01
2 Off	
3 Off	
4 Off	
5 Off	
6 Off	

Setup Procedure

1. Use the **arrow keys** to move the cursor (blue) to the item box you wish to change.
A soft key menu is displayed at the bottom of the display.
2. Press the **soft key** corresponding to the value you wish to select.
The box for the item you changed turns yellow, and the cursor moves to the next item box.
3. Repeat steps 1 and 2 to change the value of all the items you wish to change.

Note

For setup item boxes that require values to be entered, a pop-up window that appears by pressing the [Input] soft key is used.

4. Press the **DISP/ENTER key** to confirm the changes.
The boxes for the items you changed turn from yellow to white, and the cursor returns to the first item box.

Setup Item

Logic Computation Settings

- **Setting Numbers**

Up to 30 logic computations can be set. Select the numbers for the logic computations.

- **Relay**

Select the destination for the computed results.

DO001-DO006: Control output terminal block DO (for loops 1 and 2)

DO101-DO106: Control output terminal block DO (for loops 3 and 4)

DO201-DO206: Control output terminal block DO (for loops 5 and 6)

RO001-RO012: Control DIO expansion terminal block DO

SW001-SW036: Internal switches

- **Equation**

Follow the instructions in the equation pop-up window to enter the equation (using 120 characters or less). The number of data that can be used in equations is 35. You can also use the control constants W01-W36 in the equation. Measurement constants K01-K36 cannot be used.

You can use the following operators.

Computation Type	Operator
Logical operation	AND, OR, XOR, NOT
Relational operation	.GT., .LT., .GE., .LE., .EQ., .NE.
Conditional expressions	[eq1?eq2:eq3]

See *appendix 3, "Meanings and Syntax of Equations"* for information on how to create equations.

4.18 Control Constant Settings (Style Number S3 or Later)

This section explains the setting procedure for constants used for PV/SP computation, analog retransmission and logic computation (W01-W36).

Procedure

Opening the Setting Display

Press the keys in the following sequence:

MENU key (switch to setting mode(control)) > **#8 soft key** (select [Control math setting]), **#9 soft key** when program control is ON) > **#3 soft key** (Constant)

The following display appears.

Constant					
W01:	1	W13:	1	W25:	1
W02:	1	W14:	1	W26:	1
W03:	1	W15:	1	W27:	1
W04:	1	W16:	1	W28:	1
W05:	1	W17:	1	W29:	1
W06:	1	W18:	1	W30:	1
W07:	1	W19:	1	W31:	1
W08:	1	W20:	1	W32:	1
W09:	1	W21:	1	W33:	1
W10:	1	W22:	1	W34:	1
W11:	1	W23:	1	W35:	1
W12:	1	W24:	1	W36:	1

Input

Setup Procedure

1. Use the **arrow keys** to move the cursor (blue) to the item box you wish to change.
A soft key menu is displayed at the bottom of the display.
2. Press the **soft key** corresponding to the value you wish to select.
The box for the item you changed turns yellow, and the cursor moves to the next item box.
3. Repeat steps 1 and 2 to change the value of all the items you wish to change.

Note

For setup item boxes that require values to be entered, a pop-up window that appears by pressing the [Input] soft key is used.

4. Press the **DISP/ENTER key** to confirm the changes.
The boxes for the items you changed turn from yellow to white, and the cursor returns to the first item box.

Setup Item

Constant Settings

- **Constants**

You can specify the constants used in equations. Constants have 5 significant digits excluding the decimal point. When setting an exponent, use a mantissa of 5 digits or less, and an exponent of 2 digits or less.

The setting range is as follows:

–9.9999E + 29 to –1.0000E–30, 0, 1.0000E–30 to 9.9999E+29

Numerical Display Method

The display method is determined by the numeral. For $-100000 < W < -0.0001$, 0, $0.0001 < W < 100000$, a normal numeral is displayed. Otherwise, an exponent is displayed.

However, even for $-100000 < W < -0.0001$ or $0.0001 < W < 100000$, if the number has 8 characters or more including the decimal point, an exponent is used.

Significant Digits

With constants for control computations, the significant digits of the input numeral is retained. For example, if 0.010 or 1.00E20 is input, 0.010 or 1.00E20 results. However, in the following cases, the final 0 after the decimal point is insignificant.

- When a normal input value was automatically converted to an exponent
- When a value input in exponential display was automatically converted to a normal value
- When 0.00000 was entered (reverts to 0. The four places after the decimal remain as-is).

4.19 Settings for Switching the Program Patterns Using Contact Inputs with BCD Codes (Version 3.20 or Later)

In addition to the binary representation that was conventionally used to specify the program pattern number when the program pattern was switched using contact inputs, a way of specifying the program pattern using binary-coded decimal (BCD) representation has been added.

Bits Used When Specifying the Program Pattern Number Using BCD Code

Program Pattern Number Used	Pattern Number Designation Bit					
	10's digit		1's digit			
	Bit 5	Bit 4	Bit 3	Bit 2	Bit 1	Bit 0
1						✓
Up to 3					✓	✓
Up to 7				✓	✓	✓
Up to 9			✓	✓	✓	✓
Up to 19		✓	✓	✓	✓	✓
Up to 30	✓	✓	✓	✓	✓	✓

For example, set [PatternNo1bit] and [PatternNo4bit] to ON (10010) to specify pattern number [12]. Contact inputs that can be registered to [PatternNo0bit] to [PatternNo5bit] are [DI001 to DI006], [DI101 to DI106], and [DI201 to DI206] of the control output terminal block and [RI001 to RI006] of the control expansion DIO terminal block.

Procedure

Switching between BCD and Binary

Use the soft keys on the system information display to switch between binary and BCD. You cannot make the switch during control operation, during data acquisition to the internal memory, or during computation (the [Aux Setting] soft key below does not appear).

- **Switching from Binary to BCD**

1. **FUNC key > [Log] soft key > [System] soft key** (switch to SYSTEM INFO. display) > **FUNC key > [AUX Setting] soft key**

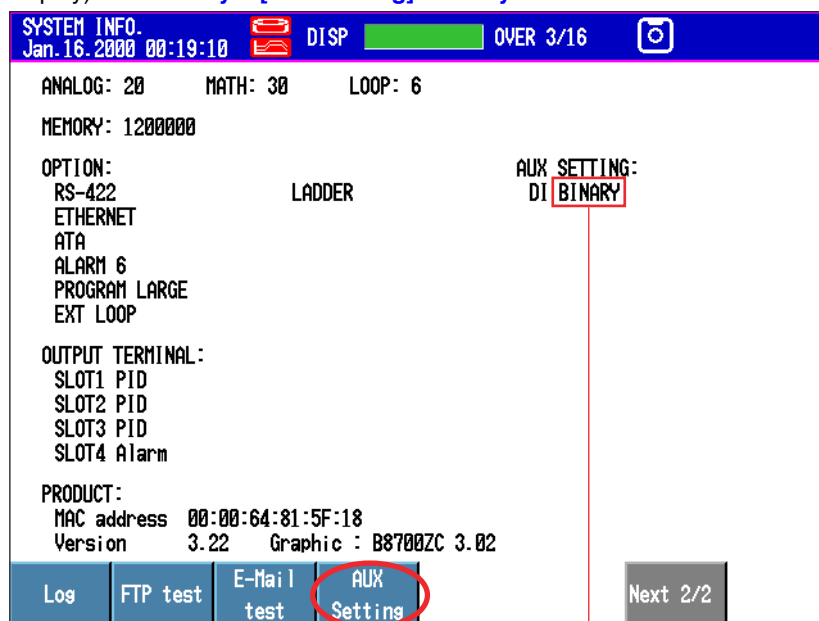

Displays the current setting (BINARY or BCD)

4.19 Settings for Switching the Program Patterns Using Contact Inputs with BCD Codes (Version 3.20 or Later)

2. Press the **[DI Config]** soft key.

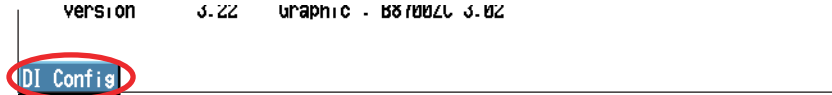

3. Press the **[BCD]** soft key.

* If BCD is currently specified, the [Binary] soft key is displayed. If binary specified, the [BCD] soft key is displayed.

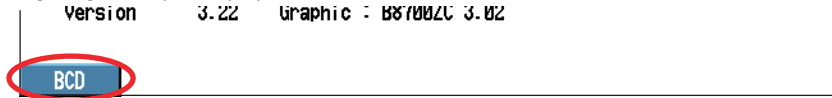

Note

- The binary/BCD setting is not saved to the setup file. Thus, the binary/BCD setting does not change even if you load the setup data into the CX. Moreover, the binary/BCD setting does not change when the CX is turned OFF.
- The binary/BCD setting cannot be changed using communication commands or a PC software application (such as DAQSTANDARD).

Registering Contact Inputs When Using BCD Codes

- **Opening the Setting Display**

MENU key (switch to Set mode (control)) > **Hold down the FUNC key for 3 seconds** (switch to basic setting mode) > **#10 soft key** (select [Control]) > **#2 soft key** (select [DI/DO/SW-registration])

The following display appears.

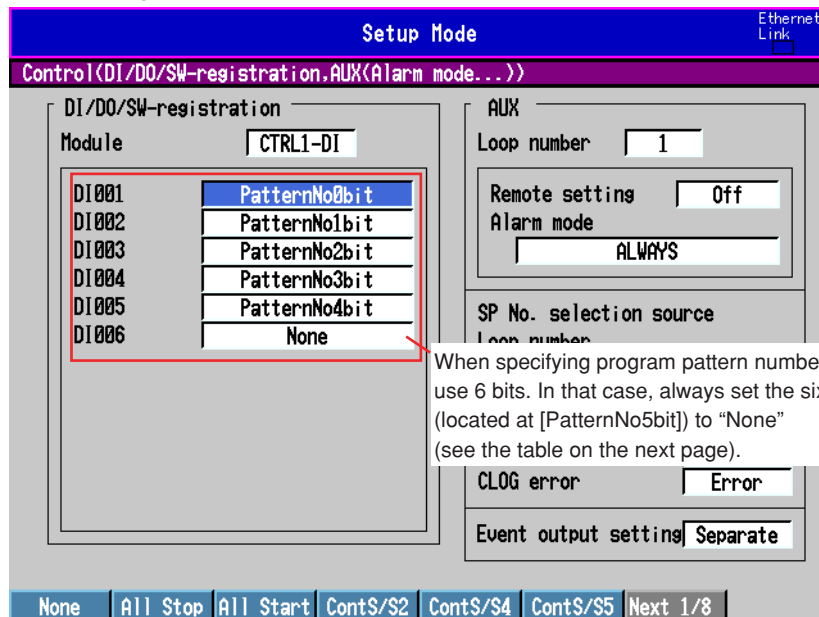

When specifying program pattern numbers 20–30, use 6 bits. In that case, always set the sixth bit (located at [PatternNo5bit]) to "None" (see the table on the next page).

4.19 Settings for Switching the Program Patterns Using Contact Inputs with BCD Codes (Version 3.20 or Later)

- **Procedure**

1. Use the **arrow keys** to move the cursor (blue) to the [Module] box.
A soft key menu is displayed at the bottom of the display.
2. Press the **soft key** corresponding to the terminal block to be used.
The box for the item you changed turns yellow, and the cursor moves to the next item.
3. Press the **soft key** corresponding to the program pattern number to be used.
The box for the item you changed turns yellow, and the cursor moves to the next item.
4. Press the **DISP/ENTER key** to confirm the changes.
The boxes for the items you changed turn from yellow to white, and the cursor returns to the first item box.

- **Save the Settings in Basic Setting Mode**

1. Press the **ESC key**.
The display returns to the basic setting menu.
2. Press the **[End] soft key**.
A confirmation dialog box appears.
3. Select [Yes] and press the **DISP/ENTER key**.
The operation screen is displayed.

Setup Items

For each of the settings other than BCD code contact input registration, see section 4.2, “Basic Control Settings > DI/DO/SW Registration, AUX (Alarm Mode...)”

DI/DO/SW-registration

Press the soft key corresponding to the program pattern number to specify.

Program Pattern Number Used	Required Number of Bits (BCD)	Setup Procedure	
		CX1000	CX2000
1	1	[Ptrn 1] soft key	[Patrn 1] soft key
Up to 3	2	[Ptrn 1 - 3] soft key	[Patrn 1 - 3] soft key
Up to 7	3	[Ptrn 1 - 7] soft key	[Patrn 1 - 7] soft key
Up to 9	4	[Ptrn 1 - 15] soft key	[Patrn 1 - 15] soft key
Up to 19	5	[Ptrn 1 - 30] soft key	[Patrn 1 - 30] soft key
Up to 30	6	[Ptrn 1 - 30] soft key	[Patrn 1 - 30] soft key
		Be sure to set [None] for the [PatternNo5bit] position.	

If you place the cursor on [DI001] (with the control output terminal block) or [RI001] (with the control DIO expansion terminal block) and press the soft key that includes the maximum pattern number to be specified, contact inputs of the required number of bits, and [DI001]-[DI005] (control output terminal block) or [RI001]-[RI005] (control DIO expansion terminal block) are automatically registered.

5.1 Program Control Related Setup Operations

To set up program control, follow the flow chart shown below.
 MENU key (switch to the setting mode (control)) > [Next 1/2] soft key

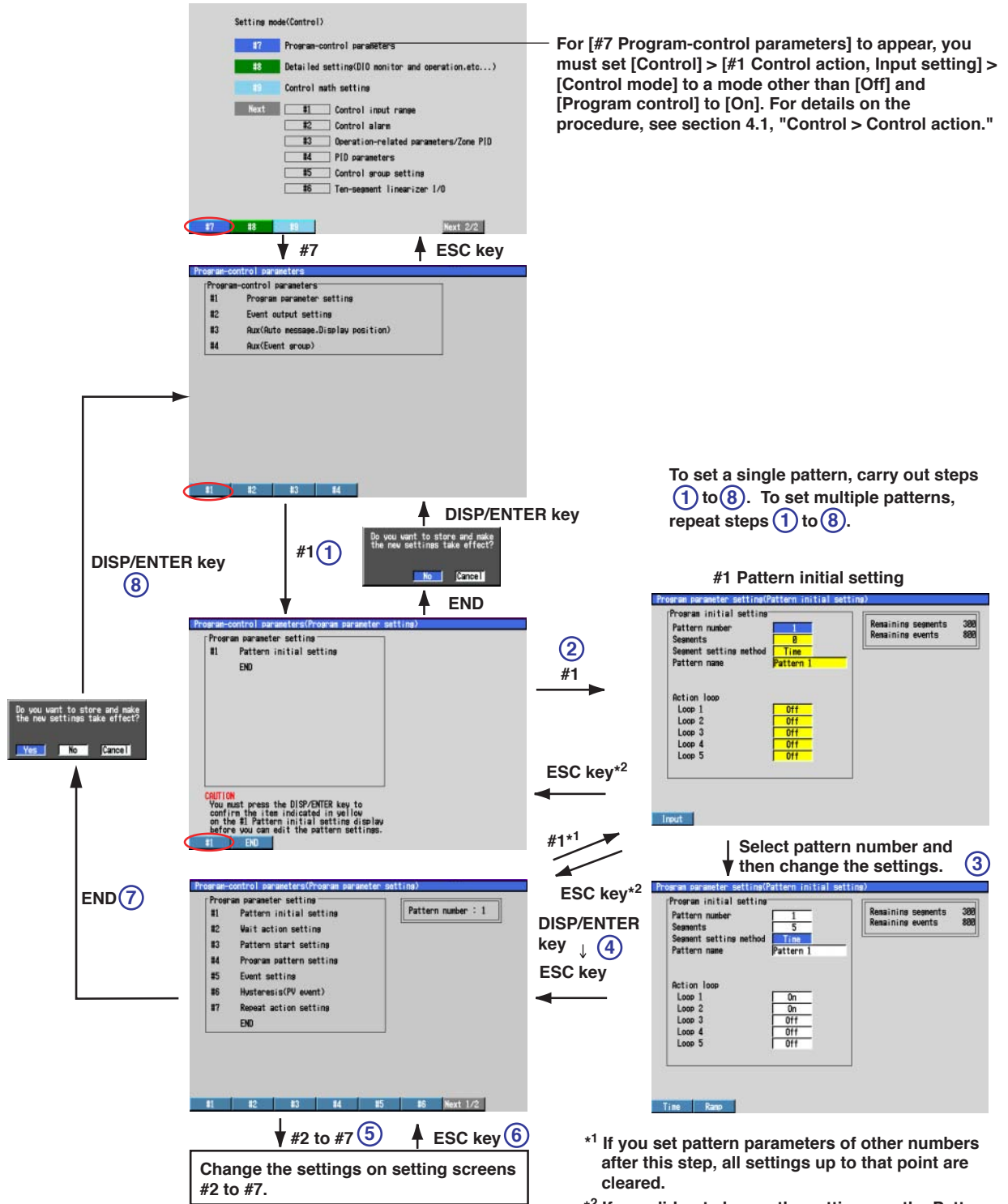

For [#7 Program-control parameters] to appear, you must set [Control] > [#1 Control action, Input setting] > [Control mode] to a mode other than [Off] and [Program control] to [On]. For details on the procedure, see section 4.1, "Control > Control action."

To set a single pattern, carry out steps ① to ⑧. To set multiple patterns, repeat steps ① to ⑧.

Note

You cannot carry out setup related to program control that is explained in this chapter when communication command "FE4" (Output setup data file) is being executed.

5.2 Program parameter setting > Pattern initial setting

This section explains how to set basic items for setting program patterns. To carry out the following procedure, you must set [Control] > [#1 Control action, Input setting] > [Control mode] to a mode other than [Off] and [Program control] to [On]. For details on the procedure, see *section 4.1, "Control > Control action."* In addition, you must carry out [Program initial setting] before you can set other [Program parameter setting] items.

Procedure

Opening the Setting Display

Press the keys in the following sequence:

MENU key (switch to the setting mode (control)) > **#7 soft key** (select [Program-control parameters]) > **#1 soft key** (select [Program parameter setting]) > **#1 soft key** (select [Pattern initial setting])

Program initial setting	
Pattern number	1
Segments	5
Segment setting method	Time
Pattern name	Pattern 1
Action loop	
Loop 1	On
Loop 2	On
Loop 3	Off
Loop 4	Off
Loop 5	Off

Remaining segments	300
Remaining events	800

Time Ramp

Note

- To carry out setup related to program control, you must press the DISP/ENTER key to confirm the settings on the pattern initial setting display even if there are no changes.
- The [Segment edit mode] entry box appears only if you set [Segments] to a value other than [0] and select a [Pattern number] that you have saved in the past. The [Edit segment number] edit box appears when you set [Segment edit mode] to [Insert] or [Delete].

Setup Procedure

1. Use the **arrow keys** to move the cursor (blue) to the item box you wish to change. A soft key menu is displayed at the bottom of the display.
2. Press the **soft key** corresponding to the value you wish to select. The box for the item you changed turns yellow, and the cursor moves to the next item.
3. Repeat steps 1 and 2 to change the value of all the items you wish to change.
4. Press the **DISP/ENTER key** to confirm the changes. The boxes for the items you changed turn from yellow to white, and the cursor returns to the first item box.
5. Press the **ESC key** to return to the [Program parameter setting] menu. To continue with program pattern setting, press the [#1] to [#6] soft keys to display each setting display without carrying out step 6.

6. Press the **[End] soft key**.

A window appears for you to confirm the saving of the new settings.

Note

If you carried out the procedure above without changing the settings, a save confirmation window with only [No] and [Cancel] appears. If you select [No] and press the DISP/ENTER key, the display returns to the [Program-control parameters] menu. If you select [Cancel] and press the DISP/ENTER key, the display returns to the previous condition.

7. Select [Yes] and press the **DISP/ENTER key** and save the settings.
The screen returns to the [Program-control parameters] menu.

Setup Items

Pattern initial setting

• **Pattern number**

Select the number of the desired pattern from [1] to [30] ([1] to [4] for models with / PG1 option).

• **Segments**

Set the number of segments to use in the program pattern of the selected number in the range of [1] to [99]. However, the total number of segments of all patterns must not exceed 300 segments. Set the value to [0] for the program pattern of an unused number.

• **Segment setting method**

Select segment time setting method or segment time ramp grade setting method. If you change this setting, the program pattern setting corresponding to the pattern number is initialized.

• **Pattern name**

Enter the pattern name using up to 16 alphanumeric characters.

• **Segment edit mode**

If you select [Delete], the segment corresponding to the number selected by [Edit segment number] is deleted, and the number of segments is decremented by 1. If you select [Insert], a segment is inserted before the segment corresponding to the number selected by [Edit segment number], and the number of segments is incremented by 1.

• **Edit segment number**

Select the number of the segment to be deleted or the position where the new segment is inserted in the range of [1] to [99] (within the number of used segments).

• **Operating Loop Designation**

Specify the loop to execute for each pattern. The loop for which Program Setting ON under Control Basic Setting was set to ON is displayed. However, loops on programs being executed cannot be changed.

5.3 Program parameter setting > Wait action setting

This section explains the procedures for setting the wait action during program control.

Procedure

Opening the Setting Display

Press the keys in the following sequence:

MENU key (switch to the setting mode (control)) > **#7 soft key** (select [Program-control parameters]) > **#1 soft key** (select [Program parameter setting]) > **#2 soft key** (select [Wait action setting])

	1		2		3		4		5		
Loop1	High	On	0.1	On	0.1	On	0.1	On	0.1	On	0.1
	Low		0.1		0.1		0.1		0.1		0.1
Loop2	High	Off		Off		Off		Off		Off	
	Low										
Loop3	High	Off		Off		Off		Off		Off	
	Low										
Loop4	High	Off		Off		Off		Off		Off	
	Low										
Loop5	High	Off		Off		Off		Off		Off	
	Low										
Loop6	High	Off		Off		Off		Off		Off	
	Low										
Wait time	00:05:00		00:00:00		00:00:00		00:00:00		00:00:00		

Setup Procedure

1. Use the **arrow keys** to move the cursor (blue) to the item box you wish to change. A soft key menu is displayed at the bottom of the display.
2. Press the **soft key** corresponding to the value you wish to select. The box for the item you changed turns yellow, and the cursor moves to the next item.
3. Repeat steps 1 and 2 to change the value of all the items you wish to change.
4. Press the **DISP/ENTER key** to confirm the changes. The boxes for the items you changed turn from yellow to white, and the cursor returns to the first item box.

Setup Items

Wait action setting

- **Wait zone Off/On**

Turn ON/OFF the wait zone for each loop. Only the loops that are set as follows are displayed: [Control] > [#1 Control action, Input setting] > [Control mode] to a mode other than [Off] and [Program control] to [On] and [Setting mode (Control)] > [#7 Program control parameters] > [#1 Program parameter setting] > [Pattern initial setting] > [Action loop] to [On]. During cascade control, even-numbered loops within the same terminal block are not displayed.

- **Wait zone values**

Set the wait zones for 6 (number of loops) × 5 (number of zones) in the range of “EUS (0.0 to 100.0%)” of the measurement span. The values can be copied and pasted using soft keys. The loops that are displayed are the same as those for [Wait zone Off/On]

- **Wait time**

Set the wait time in [hh:mm:ss] format (selectable range: [00:00:00] to [99:59:59]) for all the available zones. The setting applies to the same zones in each loop. The values can be copied and pasted using soft keys. The entry box does not appear if the wait zones of all loops are set to OFF.

5.4 Program parameter setting > Pattern start setting

This section explains the procedures for setting the start SP and conditions for starting the operation.

Procedure

Opening the Setting Display

Press the keys in the following sequence:

MENU key (switch to the setting mode (control)) > **#7 soft key** (select [Program-control parameters]) > **#1 soft key** (select [Program parameter setting]) > **#3 soft key** (select [Pattern start setting])

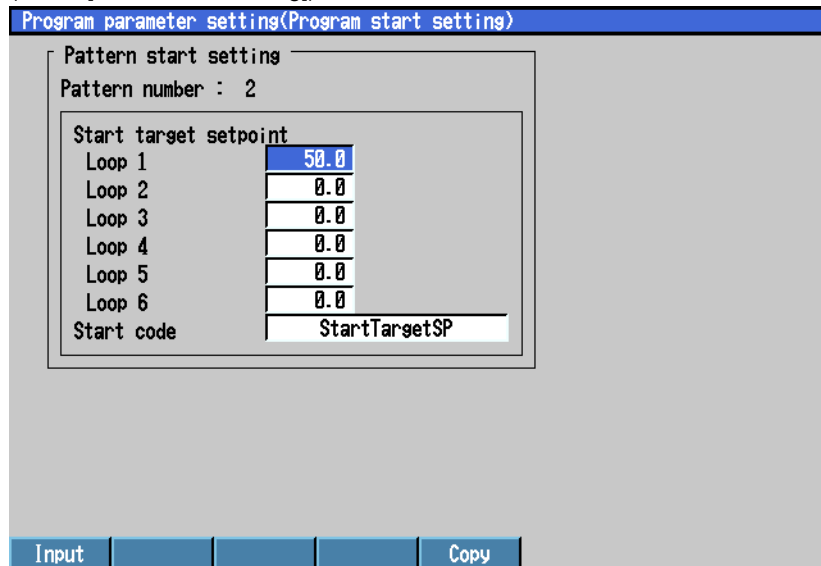

Setup Procedure

1. Use the **arrow keys** to move the cursor (blue) to the item box you wish to change. A soft key menu is displayed at the bottom of the display.
2. Press the **soft key** corresponding to the value you wish to select. The box for the item you changed turns yellow, and the cursor moves to the next item.
3. Repeat steps 1 and 2 to change the value of all the items you wish to change.
4. Press the **DISP/ENTER key** to confirm the changes. The boxes for the items you changed turn from yellow to white, and the cursor returns to the first item box.

Setup Items

Pattern start setting

- **Pattern number**
Displays the pattern number selected in the pattern initial settings.
- **Start target setpoint**
Set the start SP, a starting condition, in the range of “EU (0.0% to 100.0%)” (initial value is 0%) of the measurement span. The values can be copied and pasted using soft keys. Only the loops that are set as follows are displayed: [Control] > [#1 Control action, Input setting] > [Control mode] to a mode other than [Off] and [Program control] to [On] and [Setting mode (Control)] > [#7 Program control parameters] > [#1 Program parameter setting] > [Pattern initial setting] > [Action loop] to [On]. During cascade control, even-numbered loops within the same terminal block are not displayed.
- **Start code**
Select the operation start condition from the following. However, only the possible loop conditions are displayed.
Starting target setpoint start, PV1 to PV 6 ramp-prioritized PV start, time-prioritized ramp start (not displayed for segment time ramp setting method)

5.5 Program parameter setting > Program pattern setting

This section explains the procedures for setting the program pattern items such as the target SP of the ramp segment during program control.

Procedure

Opening the Setting Display

Press the keys in the following sequence:

MENU key (switch to the setting mode (control)) > **#7 soft key** (select [Program-control parameters]) > **#1 soft key** (select [Program parameter setting]) > **#4 soft key** (select [Program pattern setting])

Program parameter setting(Program pattern setting)

Program pattern setting

Pattern number : 2

Segment number:

Ramp/Soak select:

Target setpoint

Loop 1	<input type="text" value="50.0"/>	Loop 2	<input type="text" value="100.0"/>
Loop 3	<input type="text" value="150.0"/>	Loop 4	<input type="text" value="200.0"/>
Loop 5	<input type="text" value="300.0"/>	Loop 6	<input type="text" value="350.0"/>

Segment time:

Segment PID group No.:

Segment shift action:

Wait action:

Input Event set

Move to the event setting display
Increment/Decrement the segment number

Setup Procedure

1. Use the **arrow keys** to move the cursor (blue) to the item box you wish to change.
A soft key menu is displayed at the bottom of the display.
2. Press the **soft key** corresponding to the value you wish to select.
The box for the item you changed turns yellow, and the cursor moves to the next item.
3. Repeat steps 1 and 2 to change the value of all the items you wish to change.
4. Press the **DISP/ENTER key** to confirm the changes.
The boxes for the items you changed turn from yellow to white, and the cursor returns to the first item box.

Note

You can change the patterns even when program control is in progress. However, setting changes are not applied to the segment that is currently being executed. In addition, you cannot increase or decrease the number of segments or change the segment setting method of the pattern that is in use by program control.

Setup Items

Program pattern setting

- **Pattern number**
Displays the pattern number selected in the pattern initial settings.
- **Segment number**
Select the number of the segment to be changed from 1 to 99 (within the number of used segments).
- **Ramp/Soak select**
Select the type of segment to be specified ([Ramp] or [Soak]).

- **Target setpoint** (ramp segment only)
Set the final SP of the ramp segment in the range of “EU (0.0% to 100.0%)” (initial value is 0%) of the measurement span. The values can be copied and pasted using soft keys. Only the loops that are set as follows are displayed: [Control] > [#1 Control action, Input setting] > [Control mode] to a mode other than [Off] and [Program control] to [On] During cascade control, even-numbered loops within the same terminal block are not displayed.
- **Segment time**
Set the segment time in the range of [0:00:01] to [99:59:59] (0 hour 0 min 1 s to 99 hour 59 min 59 s). This item is displayed at all times during segment time setting method and only when soak is selected during segment time ramp setting method.
- **Ramp-rate time unit**
Set the ramp-rate time unit for ramps to [Hour] or [Minute]. This item is displayed only during ramp in the segment time ramp setting method.
- **Ramp**
Set the ramp per unit time in the range of “1 digit to EUS (100%) of the measurement span.” The measurement span and decimal point position of the selectable range vary depending on the smallest numbered loop to be specified. This item is displayed only during ramp in the segment time ramp setting method.
- **Segment PID group No.**
Select the segment PID group number [1] to [8]. This item is not displayed when zone PID is selected. Only the PID group numbers that can be specified through [Control] > [#1 Control action, Input setting] > [PID number] are displayed.
- **Segment shift action**
Set the segment shifting action to [Continue], [Hold] (hold after end of segment), [Local] (local mode after completing the last segment), or [Reset] (reset mode after completing the last segment).

Note

When creating the program pattern, data is created so that the segment set to [Local] or [Reset] is the last segment of program control.

- **Wait action**
Set the wait action type to [Shift] or [Within]. To disable the wait action, select [Off].
- **Wait zone number**
Select the wait zone number from [1] to [5]. The entry box appears only when [Wait action] is set to [Shift] or [Within].

Method of Confirming the Specified Program Pattern

In addition to confirming the settings of each segment on the program pattern setting screen, you can also confirm the specified pattern on a line drawing by showing the program control display as shown in the following figure. For the procedure in displaying and operating the program control display, see *section 6.4, “Operations on the Program Selection Display/Program Control Display.”*



5.6 Program parameter setting > Event setting

This section explains the procedures for setting the events during program control.

Procedure

Opening the Setting Display

Press the keys in the following sequence:

MENU key (switch to the setting mode (control)) > **#7 soft key** (select [Program-control parameters]) > **#1 soft key** (select [Program parameter setting]) > **#5 soft key** (select [Event setting])

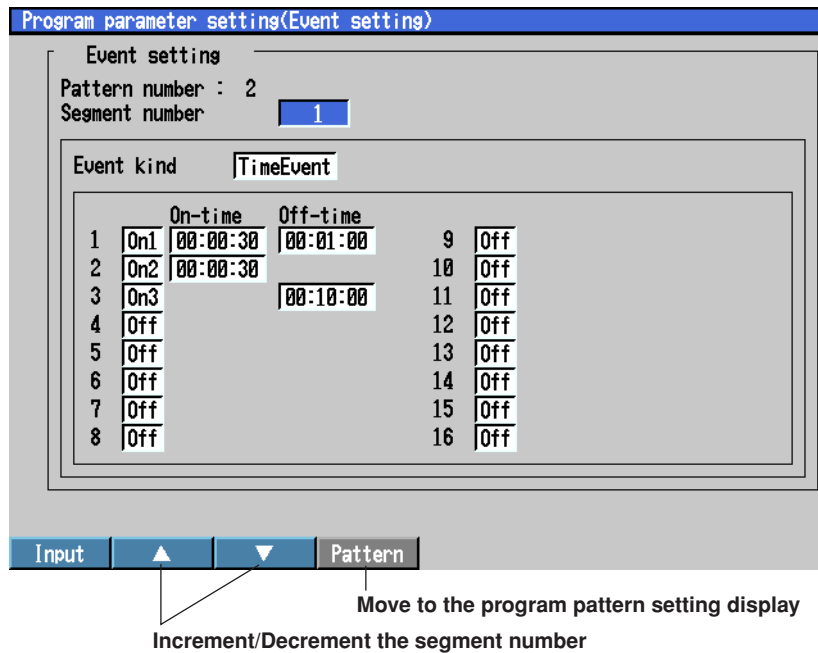

Setup Procedure

1. Use the **arrow keys** to move the cursor (blue) to the item box you wish to change. A soft key menu is displayed at the bottom of the display.
2. Press the **soft key** corresponding to the value you wish to select. The box for the item you changed turns yellow, and the cursor moves to the next item.
3. Repeat steps 1 and 2 to change the value of all the items you wish to change.
4. Press the **DISP/ENTER key** to confirm the changes. The boxes for the items you changed turn from yellow to white, and the cursor returns to the first item box.

Setup Items

Event setting

- **Pattern number**
Displays the pattern number selected in the pattern initial settings.
- **Segment number**
Set the segment number [1] to [99] to which the event is to be assigned.
- **Event kind**
Select the type of event to be assigned, [PVEvent] or [TimeEvent].
- **1 to 16**
The time event or PV event number. The number of time events and PV events that can be set per segment is 16 each.

- **Loop** (when PVEvent is selected)
Set the target loop number [1] to [6] of the PV event (only selectable loop numbers). Up to 16 events can be assigned. Select [Off] (initial setting) for the number of the loops to which the event is not to be assigned. Secondary loops of cascade control are also displayed. However, specifying such loops is void.
- **Type** (when PVEvent is selected)
Select the type of PV event from the following.
PV high-limit (PV-H), PV low-limit (PV-L), deviation high-limit (Dev-H), deviation low-limit (Dev-L), deviation high & low limit (Dev-H&L), deviation within high & low limits (D-W-H&L), SP high-limit (SP-H), SP low-limit (SP-L), output high-limit (Out-H), and output low-limit (Out-L)
- **Value** (when PVEvent is selected)
Set the value in the following range according to the type of PV event.
PV/SP event: EU (0.0 to 100.0%) of the measurement span
Deviation high-limit event/low-limit event: EUS (–100.0 to 100.0%) of the measurement span
Deviation high & low limit/within high & low limits: EUS (0.0 to 100.0%) of the measurement span
Output event: –5% to 105% of output
- **On1/On2/On3/Off** (when TimeEvent is selected)
Set the ON/OFF setting type of each event (16 events) from the following. Select [Off] for events that are not to be assigned. Select [Off] (initial setting) for the number of the loops to which the event is not to be assigned.
On1 (On/Off): Use On time and Off time
On2 (On/**): Use On time only
On3 (**/Off): Use Off time only
- **On-time/Off-time** (when TimeEvent is selected)
Set the ON-time/OFF-time of the time event in “hh:mm:ss” format. The selectable range is “00:00:00 to 99:59:59.” Set On-time ≤ Off-time.

5.7 Program Pattern Settings > Hysteresis (PV Event)

This section explains the PV event hysteresis setting procedure during program control.

Procedure

Opening the Setting Display

Press the keys in the following sequence:

MENU key (switch to setting mode(control)) > **#7 soft key** (select [Program-control parameters]) > **#1 soft key** (select [Program parameter setting]) > **#6 soft key** (select [Hysteresis (PV event)])

The following display appears.

Hysteresis(PV event)	
PV event	Hysteresis
1	0.5%
2	0.5%
3	0.5%
4	0.5%
5	0.5%
6	0.5%
7	0.5%
8	0.5%
9	0.5%
10	0.5%
11	0.5%
12	0.5%
13	0.5%
14	0.5%
15	0.5%
16	0.5%

Input

Setup Procedure

1. Use the **arrow keys** to move the cursor (blue) to the item box you wish to change.
A soft key menu is displayed at the bottom of the display.
2. Press the **soft key** corresponding to the value you wish to select.
The box for the item you changed turns yellow, and the cursor moves to the next item box.
3. Repeat steps 1 and 2 to change the value of all the items you wish to change.
4. Press the **DISP/ENTER key** to confirm the changes.
The boxes for the items you changed turn from yellow to white, and the cursor returns to the first item box.

Setup Item

- **PV event hysteresis (only on models with the program control option)**
For each PV event 1-16, set the hysteresis in the range from 0.0 to 10.0%.

5.8 Program parameter setting > Repeat action setting

This section explains the procedures for setting the repeat function during program control.

Procedure

Opening the Setting Display

Press the keys in the following sequence:

MENU key (switch to the setting mode (control)) > **#7 soft key** (select [Program-control parameters]) > **#1 soft key** (select [Program parameter setting]) > **#7 soft key** (select [Repeat action setting])

Program parameter setting(Repeat action setting)	
Repeat setting	
Pattern number :	2
Repeat action	On
Repeat frequency	1
Repeat start segment	1
Repeat end segment	10
Off On Repeat	

Setup Procedure

1. Use the **arrow keys** to move the cursor (blue) to the item box you wish to change. A soft key menu is displayed at the bottom of the display.
2. Press the **soft key** corresponding to the value you wish to select. The box for the item you changed turns yellow, and the cursor moves to the next item.
3. Repeat steps 1 and 2 to change the value of all the items you wish to change.
4. Press the **DISP/ENTER key** to confirm the changes. The boxes for the items you changed turn from yellow to white, and the cursor returns to the first item box.

Setup Items

Repeat action setting

- **Pattern number**
Displays the pattern number selected in the pattern initial settings.
- **Repeat action**
Select the repeat function from [Off], [On], and [Repeat].
- **Repeat frequency**
Set the number of repetitions when the repeat function is turned ON in the range of [1] to [999].
- **Repeat start segment/Repeat end segment**
Set the repeat start segment number and the repeat end segment number when the repeat function is turned ON or when repeating in the range of "1 to 99." However, the selectable range for the maximum value is the value specified for [#1 Pattern initial setting] > [Segments]. Set repeat start segment ≤ repeat end segment.

5.9 Event Output Settings

This section explains the setting procedure for event output during program control and program pattern end signaling.

Procedure

Opening the Setting Display

Press the keys in the following sequence:

MENU key (switch to setting mode(control)) > **#7 soft key** (select [Program-control parameters]) > **#2 soft key** (select [Event output setting])

The following display appears.

Event output					
Pattern number	1	Event kind	TimeEvent		
Relay Output	Number	Action	Relay Output		
EV 1	On	D0001	Energize	EV 9	Off
EV 2	On	D0002	Energize	EV10	Off
EV 3	On	D0003	Energize	EV11	Off
EV 4	Off			EV12	Off
EV 5	Off			EV13	Off
EV 6	Off			EV14	Off
EV 7	Off			EV15	Off
EV 8	Off			EV16	Off

Program pattern end signal		
Relay Output	Number	Action
On	D0001	Energize

Setup Procedure

1. Use the **arrow keys** to move the cursor (blue) to the item box you wish to change.
A soft key menu is displayed at the bottom of the display.
2. Press the **soft key** corresponding to the value you wish to select.
The box for the item you changed turns yellow, and the cursor moves to the next item box.
3. Repeat steps 1 and 2 to change the value of all the items you wish to change.
4. Press the **DISP/ENTER key** to confirm the changes.
The boxes for the items you changed turn from yellow to white, and the cursor returns to the first item box.

Setup Item

Event Output Settings

- **Pattern number (Version 3.02 or later)**

Displayed when event output is set for each program pattern. Select a program pattern number for which to set event output.

If this item is not displayed, the event output is common to all program patterns.

- **Event Types**

Select whether to set event output for PV event or time event.

- **Relay Output**

Turn the relay output ON or OFF.

- **Number**

Select relay output terminal numbers from the following.

DO001-006, DO101-106, DO201-206, RO001-012 (only with the control DIO expansion terminal block), SW001-SW036 (internal switches, style number S3 or later)

- **Action**

Displays the relay output action (energize/de-energize) per the settings.

Program Pattern End Signal Setting (Not Per Pattern, but Overall)

- **Relay Output**

Turn the relay output ON or OFF.

- **Number**

Select relay output terminal numbers from the following.

DO001-006, DO101-106, DO201-206, RO001-012 (only with the control DIO expansion terminal block), SW001-SW036 (internal switch, style number S3 or later)

- **Action**

Displays the relay output action (Energize/Deenergize) per the settings.

5.10 AUX (Auto message, Display position)

This section explains the procedures for setting auto message printing during program control and the display position for each loop on the program control display.

Procedure

Opening the Setting Display

Press the keys in the following sequence:

MENU key (switch to the setting mode (control)) > **#7 soft key** (select [Program-control parameters]) > **#3 soft key** (AUX (Auto message, Display position))

Program-control parameters(Aux(Auto message,Display position))

Aux(Auto message,Display position)

Auto message for program Run/Reset
On/Off On

Program display position

Loop	Position	Tag	Tag comment
Loop 1	1	INT-01	
Loop 2	2	INT-02	
Loop 3	3	INT-03	
Loop 4	4	INT-04	
Loop 5	5	INT-05	

Auto change to program run display
On/Off Off

On Off

Setup Procedure

1. Use the **arrow keys** to move the cursor (blue) to the item box you wish to change. A soft key menu is displayed at the bottom of the display.
2. Press the **soft key** corresponding to the value you wish to select. The box for the item you changed turns yellow, and the cursor moves to the next item.
3. Repeat steps 1 and 2 to change the value of all the items you wish to change.
4. Press the **DISP/ENTER key** to confirm the changes. The boxes for the items you changed turn from yellow to white, and the cursor returns to the first item box.

Setup Items

Auto message for program Run/Reset

• On/Off

If you select [On] (initial setting), a message is automatically written on the trend display when program control is started and when program control is stopped as shown in the figure below. If you do not wish to write messages, select [Off]. The message upon program operation start is "Pattern name top 12 characters + space + RUN", and the message upon program operation stop is "Pattern name top 12 characters + space + RST".

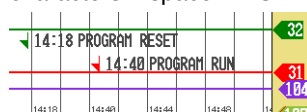

Program display position

• **Position**

On the program selection display and program control display, the specified patterns and PV waveforms can be displayed in the same display frame (full display) as well as display data by dividing the display position per loop (split display). When using split display, select the display position number from [1] to [6] for each loop. Applicable loops are those set to [Control] > [#1 Control action, Input setting] > [Control mode] to a mode other than [Off] and [Program control] to [On]. During cascade control, even-numbered loops within the same terminal block are not displayed.

Full display example

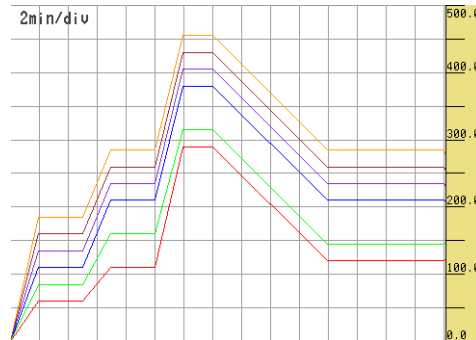

Split display example (six divisions)

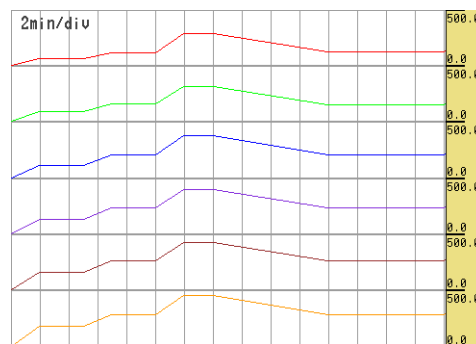

Setting
 Loop 1: 1
 Loop 2: 2
 Loop 3: 3
 Loop 4: 4
 Loop 5: 5
 Loop 6: 6

Split display example (three divisions)

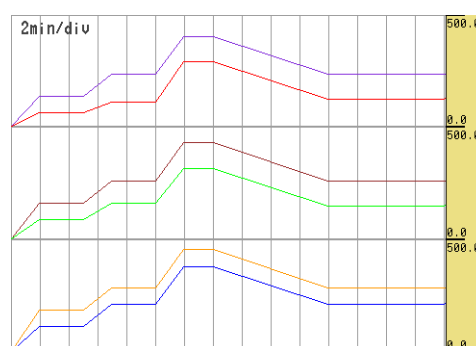

Setting
 Loop 1: 1
 Loop 2: 2
 Loop 3: 3
 Loop 4: 1
 Loop 5: 2
 Loop 6: 3

• **Operation Display Automatic Switching (Style Number S3 or Later)**

When a program execution command is sent via the communication function, you can have it switch to the program operation display.

ON: Switches to the program operation display when a program execution command is sent.

OFF: Does not switch to the program operation display (default) even if a program execution command is sent.

5.11 AUX (Event Group) Settings (Style Number S3 or Later)

This section explains the setting procedure for event groups displayed in the program selection screen and program operation display.

Procedure

Opening the Setting Display

Press the keys in the following sequence:

MENU key (switch to setting mode(control)) > **#7 soft key** (select [Program-control parameters]) > **#4 soft key** (select [AUX (Event group)])

The following display appears.

	Kind	Number
1	On	TimeEvent 01
2	On	TimeEvent 02
3	On	TimeEvent 03
4	On	TimeEvent 04
5	On	TimeEvent 05

Setup Procedure

1. Use the **arrow keys** to move the cursor (blue) to the item box you wish to change.
A soft key menu is displayed at the bottom of the display.
2. Press the **soft key** corresponding to the value you wish to select.
The box for the item you changed turns yellow, and the cursor moves to the next item box.
3. Repeat steps 1 and 2 to change the value of all the items you wish to change.
4. Press the **DISP/ENTER key** to confirm the changes.
The boxes for the items you changed turn from yellow to white, and the cursor returns to the first item box.

Setup Item

Event Display Groups

See section 5.6, "Program Parameter Setting > Event Setting" for information on event settings.

- **Pattern Number**
Enter a group for each program pattern. You can display events registered to pattern groups selected in the program selection screen.
- **Detail**
Select either time event or PV event.
- **Number**
Select numbers of events selected by type.

6.1 Operations on the Control Group Display (Switching Displayed Information and Control Operation Modes)

This section explains the operations that you can perform on the control group display. Similar operations can be performed also on the control overview display. On the control display, you cannot switch the run/reset mode or switch to hold operation for program control. These operations are performed on the program control display. For details, see section 6.4, "Operations on the Program Control Display."

Procedure

Switching the Display Group, Display Style, and Display Screen

- **Using the display selection menu**
 1. Press the **DISP/ENTER** key to show the display selection menu.
 2. With [Control] selected, press the **right arrow key** to display the sub menu.

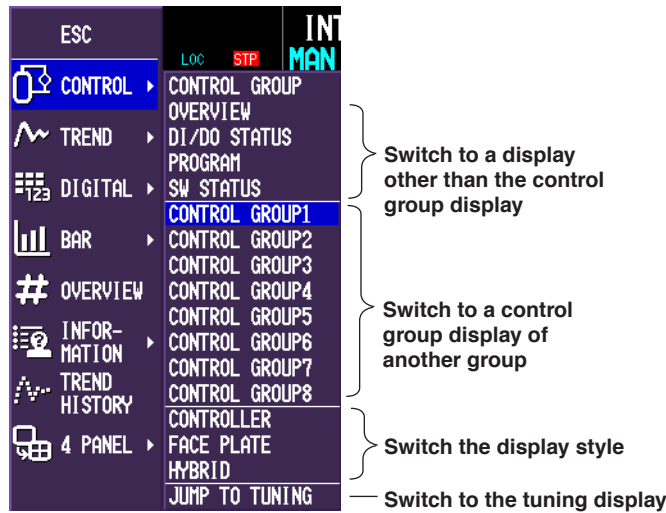

3. Select the desired item using the **up and down arrow keys**.
4. Press the **DISP/ENTER** key to show the selected display.

- **Switching the display group and display style using arrow keys**

You can also switch the display through the following procedure with the control group display showing. The display group or display style switches in order while the arrow key is pressed.

Switching the display group: Press the **left or right arrow key** for more than 1 s (right arrow key: 1→2→...→8→1, left arrow key: in reverse order).

Switching the display style: Press the **up or down arrow key** for more than 1 s (down arrow key: controller→faceplate→hybrid→controller, up arrow: in reverse order).

Run/Stop Operation

For cascade control, the following operations can be performed only when the secondary loop is selected.

1. Use the **arrow keys** to move the cursor to the desired control loop.

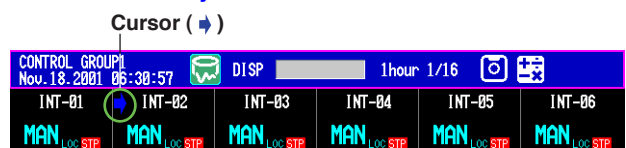

6.1 Operations on the Control Group Display (Switching Displayed Information and Control Operation Modes)

2. Press the **[RUN/STP]** soft key.

A pop-up window for running and stopping the operation appears.

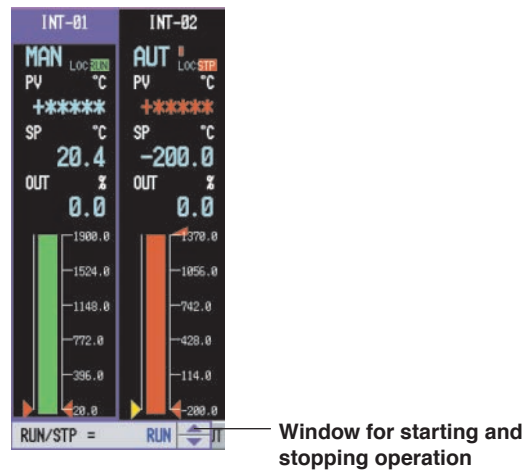

3. Select [RUN] or [STOP] using the **up and down arrow keys**.
4. Press the **DISP/ENTER** key to confirm the changes.

To close the window without making any changes, press the ESC key.

Switching between Auto, Manual, and Cascade Control

You can only switch to the cascade mode on the secondary loop of cascade control.

1. Use the **arrow keys** to move the cursor to the desired control loop.
2. Press the **[Mode]** soft key.

The MODE selection pop-up window appears.

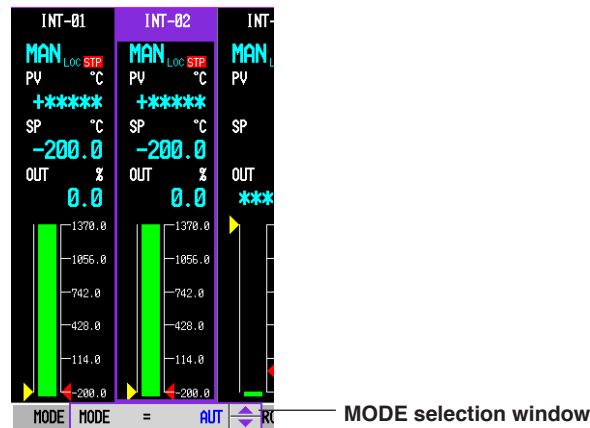

3. Select [AUT] (auto), [MAN] (manual), [CAS] (cascade) using the **up and down arrow keys**.
 4. Press the **DISP/ENTER** key to confirm the changes.
- To close the window without making any changes, press the ESC key.

Changing the SP

1. Use the **arrow keys** to move the cursor to the desired control loop.

6.1 Operations on the Control Group Display (Switching Displayed Information and Control Operation Modes)

2. Press the **[SP]** soft key.

The SP modification pop-up window appears. The window shows the current SP.

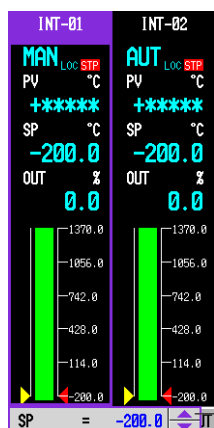

Window for changing the target setpoint

3. Change the SP using the **up and down arrow keys**.
The value changes continuously if you keep pressing the up or down arrow key.
4. Press the **DISP/ENTER** key to confirm the changes.
To close the window without making any changes, press the ESC key.

Changing the Control Output

The following operation cannot be performed during auto operation, when operation is stopped, or when the primary loop of cascade control is selected. When the operation is stopped, the preset value is output.

1. Use the **arrow keys** to move the cursor to the desired control loop.
2. Press the **[OUT]** soft key.

The OUT modification pop-up window appears. The window shows the current control output.

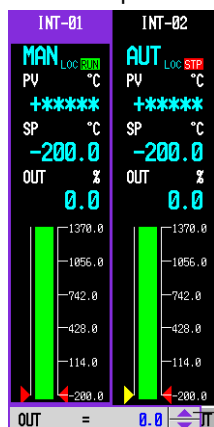

Window for changing the control output

3. Change the control output using the **up and down arrow keys**. This procedure changes the control output value to the changed value.
The value changes continuously if you keep pressing the up or down arrow key.

Note

If [Shutdown] under [PID parameter] is set to [On], the next value below [-5.0]% is [SD], which indicates shutdown, when you keep decreasing the control output.

4. Press the **DISP/ENTER** key to conclude changes to the control output value.
To close the window without making any changes, press the ESC key.

6.1 Operations on the Control Group Display (Switching Displayed Information and Control Operation Modes)

Switching between Remote and Local Modes

The soft key menu does not show [REM/LOC], if [Control] > [Contact input-registration/AUX(Alarm mode...)] > [Remote setting] is set to [Off]. Remote input cannot be used for the SP when the secondary loop of cascade control is selected or during program control. Thus, there is no remote/local switching in these cases.

1. Use the **arrow keys** to move the cursor to the desired control loop.
2. Press the **[REM/LOC] soft key**.

A pop-up window for switching between remote and local appears.

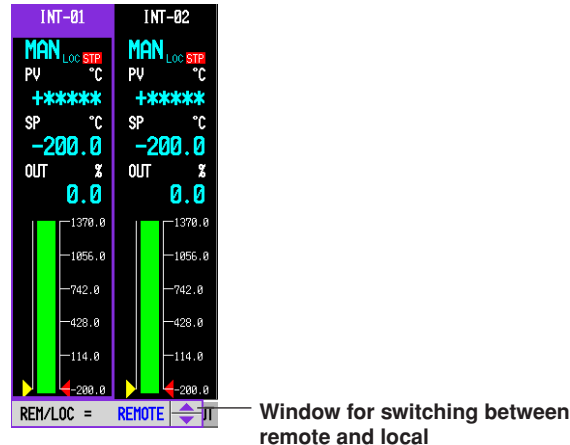

3. Select [REMOTE] or [LOCAL] using the **up and down arrow keys**.
4. Press the **DISP/ENTER key** to confirm the changes.

To close the window without making any changes, press the ESC key.

Switching between Program and Local Control (only on models with the program control option)

The soft key menu does not show [PRG/LOC] if [Program control] is set to [Off].

1. Use the **arrow keys** to move the cursor to the desired control loop.
2. Press the **[PRG/LOC] soft key**.

A pop-up window for switching between program and local appears. The window shows the current control output.

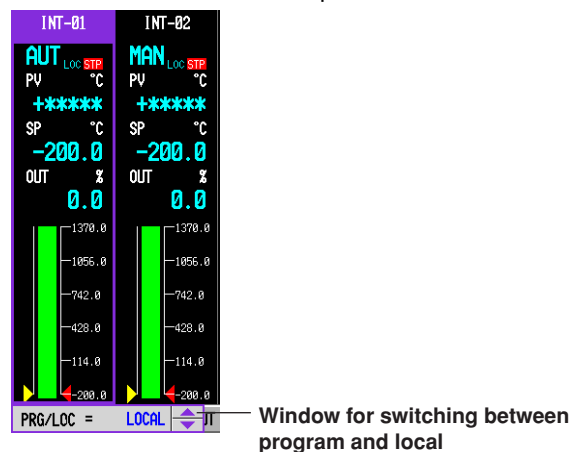

3. Select [PROGRAM] or [LOCAL] using the **up and down arrow keys**.
4. Press the **DISP/ENTER key** to confirm the changes.

To close the window without making any changes, press the ESC key.

Switching to Tuning Display

1. Use the **arrow keys** to move the cursor to the desired control loop.
2. Press the **[TUNING] soft key**.

For the operations on the turning display, see *section 6.3, "Tuning Operation."*

Switching to the Program Selection Screen

1. Use the **arrow keys** to move the cursor to the desired control loop.
2. Press the **[PROGRAM] soft key**. The display switches to the program selection screen for the pattern included in the loop selected by the cursor, or to the program operation display.

For operations in the program selection screen, see *section 6.4, "Operations on the Program Selection Display and Program Control Display (Only on Models with the Program Control Option)."*

Switching between Automatic and Manual for the Analog Retransmission Loop

You can switch the output mode for the control loop specified for analog retransmission. When set to AUTO, the computed result of analog retransmission is output. When set to MAN, you can set the direct output value.

1. Use the **arrow keys** to move the cursor to the desired control loop.
2. Press the **[MODE] soft key**.

A pop-up window switching between auto and manual appears.

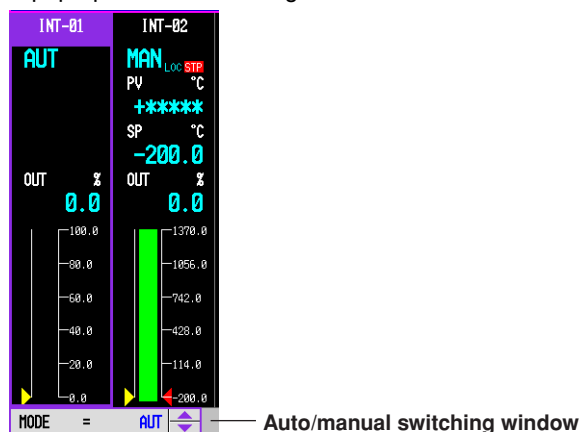

3. Select [AUTO] or [MAN] using the **up and down arrow keys**.
4. Press **DISP/ENTER key** to confirm the changes.
To close the window without making any changing, press the ESC key.

Output Value Changes for Analog Retransmission Loops

MAN must be set for the MODE using the procedure above.

1. Use the **arrow keys** to move the cursor to the desired control loop
2. Press the **[OUT] soft key**. The Output Value Setting window appears.

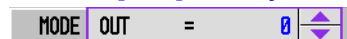

3. Change the output value using the **up and down arrow keys**. The currently set control output value is displayed in the window.

6.1 Operations on the Control Group Display (Switching Displayed Information and Control Operation Modes)

DO Automatic and Manual Switching Specified in the DIO Operation Monitoring Function

You can switch the output mode for the DO specified in the DIO Operation Monitoring Function. When set to AUTO, the internal switch status is output. When set to MAN, you can switch the direct output value between 0 and 1.

1. Use the **arrow keys** to move the cursor to the desired control loop.
2. Press the **[MODE] soft key**.

A pop-up window switching between auto and manual appears.

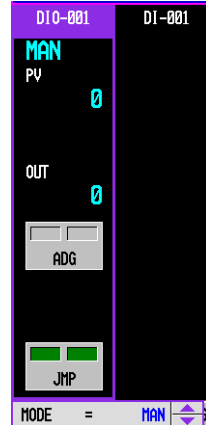

Auto/manual switching window

3. Select Select [AUTO] or [MAN] using the **up and down arrow keys**.
4. Press **DISP/ENTER key** to confirm the changes.

To close the window without making any changing, press the ESC key.

Changing the Output Value of the DO Specified with the DIO Operation Monitoring Function

MAN must be set for the MODE using the procedure above.

1. Use the **arrow keys** to move the cursor to the desired control loop.
2. Press the **[OUT] soft key**. The Output Value Setting window appears.

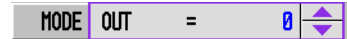

3. Change the output value using the **up and down arrow keys**. The currently set control output value is displayed in the window.

Setup Items

Run/Stop Operation

The following operations cannot be performed if the operation is started.

- Settings in basic setting mode
If you attempt to enter basic setting mode, an error message “This action is not possible during sampling, calculating or controlling” appears.
- Control input range of setting mode (control)
You can set the [Bias] and [Filter] parameters on the same display.
If you attempt to change the settings, an error message “Range cannot be changed during sampling, calculating or controlling” appears.
- [Math Set1] and [Math Set 2] in setting mode and [Save/Load, Clear data] > [Format] and [Clear data]
If you attempt to change the settings, an error message “Range cannot be changed during sampling, calculating or controlling” appears.

The following behavior results when the operation is stopped.

- Control output: Preset value (initial value is 0%)
- Event output: OFF

6.1 Operations on the Control Group Display (Switching Displayed Information and Control Operation Modes)

Display and Operation on the Control Display and Control Mode

For internal loops, the information that is displayed in the control data display section (“Dsp.” in the following table) and the possible switching/setting operations (“Opr.” in the following table) vary depending on the control mode as shown in the following figure.

For a description on the “control mode and switching operation” of external loops through the optional Green series communications, see the *DAQSTATION CX1000/CX2000 Communication Interface User's Manual*.

MODE: Auto (AUT), manual (MAN), or cascade (CAS)

REM/LOC: Remote or local (PRG/LOC: Program or local^{*3})

RUN/STP: Operation running (RUN) or operation stopped (STP)

SP: Target setpoint

OUT: Control output

Operation Status/ Switching		MODE		REM/LOC ^{*3}		RUN/STP		SP		OUT	
		Dsp.	Opr.	Dsp.	Opr.	Dsp.	Opr.	Dsp.	Opr.	Dsp.	Opr.
Control Mode		Yes	Yes	Yes	Yes ^{*1}	Yes	Yes	Yes	Yes	Yes	Yes
Single loop		Yes	Yes	Yes	Yes ^{*1}	Yes	Yes	Yes	Yes	Yes	Yes
Cascade	Primary	Yes ^{*2}	No	Yes	Yes ^{*1}	No	No	Yes	Yes	Yes	No
	Secondary	Yes	Yes	No	No	Yes	Yes	Yes	Yes	Yes	Yes
PV switching		Yes	Yes	Yes	Yes ^{*1}	Yes	Yes	Yes	Yes	Yes	Yes

^{*1} Not displayed on the soft key menu if [Remote setting] and [Program control] are set to [Off].

^{*2} Fixed to auto (AUT).

^{*3} “PRG/LOC” when [Program control] is [On].

In addition, the following table shows the conditions in which the soft key menu for switching/setting appears, but operation is not possible.

Switching/Setting Operation	Condition in Which Operation Is Not Possible	Corrective Action
Switching to [CAS] using [MODE]	When “A/D error”, “burnout error”, or “Computation Error” ^{**} occurs at the PV input or remote input of cascade control the primary side	Resolve the cause of error on on the primary loop
Switching to [REM] using [REM/LOC]	When “A/D error”, “burnout error”, or “Computation Error” ^{**} the remote input	Resolve the cause of error at occurs at the remote input.
Switching to [PRG] using [PRG/LOC]	When program control is in reset mode	Switch to [RUN] of program control
Changing [SP]	During auto tuning, remote mode, program mode, or cascade control (when [MODE]of the secondary loop is [CAS])	Stop auto tuning, switch to local mode, or switch to auto/manual operation
Changing [OUT]	When the operation is stopped or when operation mode is not manual ([MODE] is not [MAN])	Switch to manual operation

^{*} When the computation of the loop specified in PV/SP computed results in an error.

• Error messages for the operations above

Switching to [CAS] using [MODE]: Cascade mode cannot be selected.

Switching to [REM] using [REM/LOC]: Remote mode cannot be selected.

Switching to [PRG] using [PRG/LOC]: Program mode cannot be selected.

Changing [SP] or [OUT]: Can not operate in the present situation.

6.2 Switching Displays on the Overview Display

Since the control overview display cannot show the control status of all groups on a single display, two displays (overview 1 that displays groups 1 to 4 and overview 2 that displays groups 5 to 8) are used. This section explains how to switch between the two. For the operations on the control display and common operations such as changing the display style or operation mode on the control overview display, see *section 6.1, "Operations on the Control Group Display (Switching Displayed Information and Control Operation Modes)."*

Procedure

Switching the Overview Display

- **Using the display selection menu**

Perform the following operation with the control overview display showing.

1. Press the **DISP/ENTER** key to show the display selection menu.
2. With [Control] selected, press the **right arrow** key to display the sub menu.
3. Select [Overview1] to show the overview display of groups 1 to 4 or [Overview2] to show the overview display of groups 5 to 8 using the **up and down arrow** keys.



4. Press the **DISP/ENTER** key to show the selected display .

- **Using the arrow keys**

Switching is possible by pressing the **left or right arrow** key for more than 1 s with the control group display showing. Switching continues while the arrow key is pressed.

Switch to Program Selection Screen

1. Use the **arrow** keys to move the cursor to the desired control loop.
2. Press the **[PROGRAM]** soft key. The display switches to the program selection display for the pattern included in the loop selected by the cursor, or to the program operation display.

For operations in the program selection display, see *section 6.4, "Operations in the Program Selection Display/Program Operation display (Only for Models with the Program Control Option)."*

6.3 Tuning Operation

This section explains how to perform auto tuning of PID constants, manual tuning of control parameters, and other operations on the tuning display.

Procedure

Opening the Tuning Display

The tuning display can be displayed using either of the following method.

- Press the [TUNING] soft key on the control group display.
- On the control group display or control overview display, select [CONTROL] > [JUMP TO TUNING] from the screen selection menu (see *page 6-1*.)

Auto Tuning

1. Press the **[AUTO TUN]** soft key.

As shown in the following figure, the auto tuning setup pop-up window appears along with a warning message.

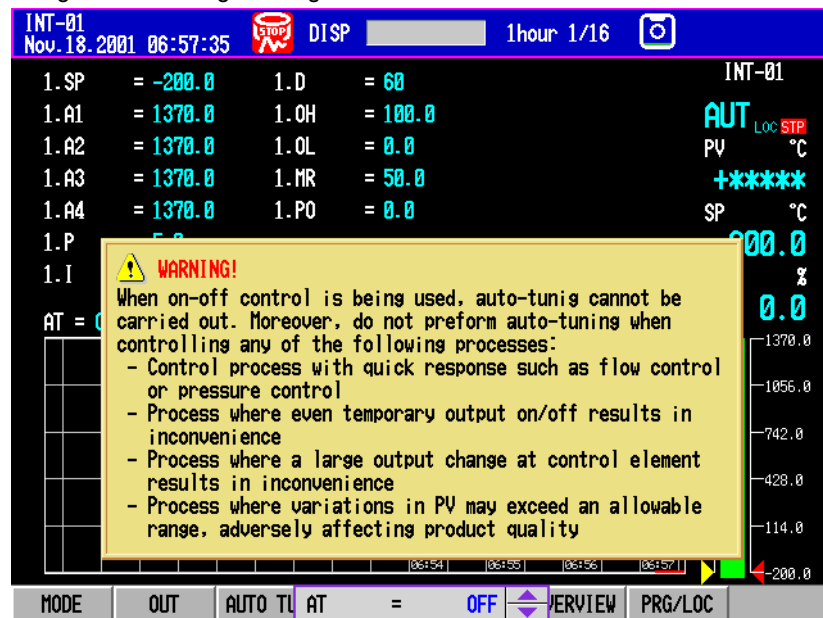

2. Select the PID group for auto tuning using the **up and down arrow keys**. If you select [ALL], all PID groups are targeted for auto tuning.

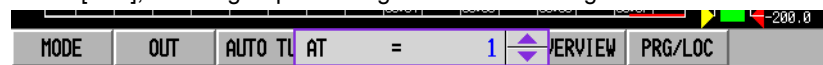

3. Press the **DISP/ENTER** key to execute auto tuning.

CAUTION

- You cannot execute auto tuning during ON/OFF control.
- Do not execute auto tuning when controlling the following types of processes. If you do, malfunction may occur in the control process.
 - Control process with fast response such as flow control and pressure control.
 - Process that results in adverse consequences when the output is turned on/off even if temporarily.
 - Process that results in adverse consequences if a large output change is applied to the control element.
 - Process that may cause adverse effects on the quality of a product when the PV exceeds the allowed fluctuation width.

Manual tuning

1. Press the **arrow key**.
A cursor appears in the control parameter display section.
2. Select the control parameter you wish to change using the **arrow keys**.
3. Press the **DISP/ENTER key**.

The parameter modification pop-up window appears.

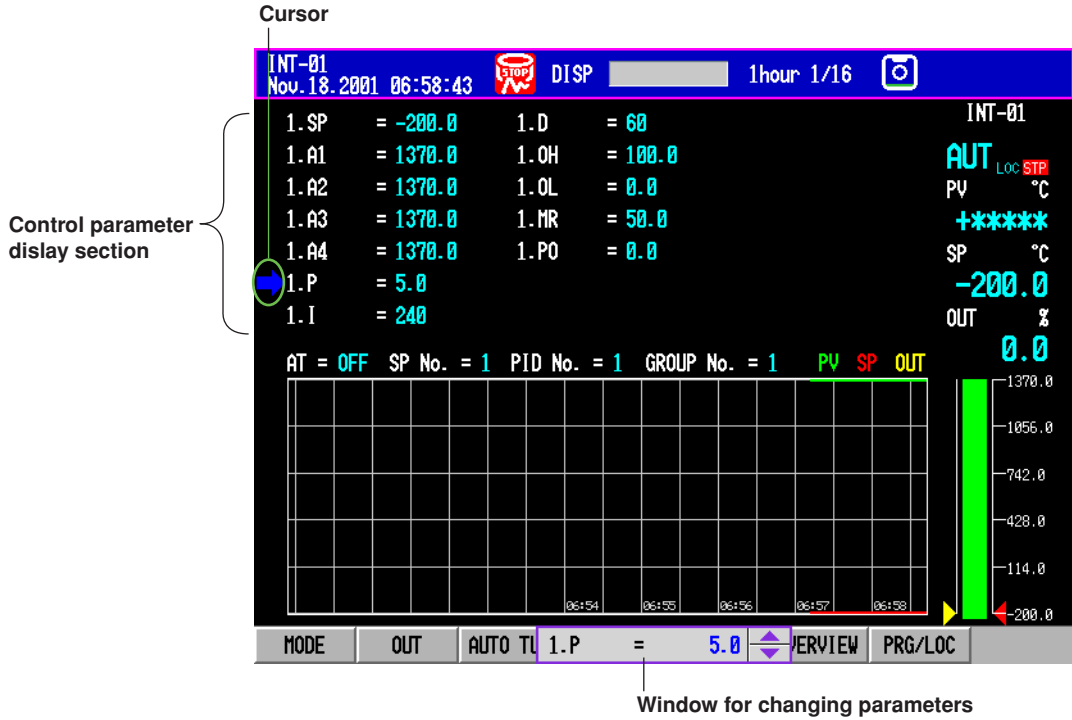

4. Change the value using the **up and down arrow keys**.
The value changes continuously if you keep pressing the up or down arrow key. With control computation constants (W01-W36), only the mantissa of the exponential display is displayed, and can be changed.
5. Press the **DISP/ENTER key** to confirm the changes.
To close the window without making any changes, press the ESC key.

Changing the SP Number (SP NO.)/PID Number (GROUP NO.) of the Tuning Parameter to Be Manipulated

1. Press the **[SP NO.] soft key** to change the SP number. Press the **[Group No.] soft key** to change the PID number.
A pop-up window for changing the SP number or a pop-up window for changing the PID number appears.
2. Change the SP number or the PID number using the **up and down arrow keys**.
3. Press the **DISP/ENTER key**.
To close the window without making any changes, press the ESC key.

Switching Run/Stop and Auto/Manual and Changing the Control Output

These operations are the same as the operations on the control group display. See section 6.1, "Operations on the Control Group Display (Switching Displayed Information and Control Operation Modes)."

Reverting to the Control Group Display or Control Overview Display

If the tuning display was displayed from the control group display, the soft key menu shows [CTRL GRP]. If it was displayed from the control overview display, the soft key menu shows [OVERVIEW]. To return to those displays, press the appropriate **soft key**.

Setup Items

Manual Tuning

Set the parameters to be tuned using [Control] > [Turning setting]. For the procedure, see *section 4.5, "Control > Tuning setting."*

The initial settings of the tuning parameters are shown below. The numbers indicate the order of items on the tuning display starting from the upper left corner. The characters indicate the item names (tuning parameter name). In addition to the tuning parameters below, [DR] (control direction) and [H] (relay hysteresis) are available. For external loops using Green Series communications, [DB] (dead band) is also available.

01: SP (target setpoint)	08: D (derivative time)	15: Off
02: A1 (alarm value1)	09: OH (output high-limit)	16: Off
03: A2 (alarm value 2)	10: OL (output low-limit)	17: Off
04: A3 (alarm value 3)	11: MR (manual reset)	18: Off
05: A4 (alarm value 4)	12: PO (preset output)	19: Off
06: P (proportional band)	13: Off	20: Off
07: I (integral time)	14: Off	21: Off

Display and Operation on the Tuning Display and Control Mode

For internal loops, the possible operations that you can perform on the tuning display vary depending on the control mode.

The table below shows the relationship between the display/operations specific to the tuning display and the control mode. For the relationship between the display/operations that are common with the control display and the control mode, see "Display and Operation on the Control Display and Control Mode" on *page 6-6*. For a description on the "display/operations and control mode" of external loops through the optional Green series communications, see the *DAQSTATION CX1000/CX2000 Communication Interface User's Manual*.

AT: Execute auto tuning

SP NO.: Switch the SP number

Group NO.: Switch the PID number of the tuning parameter to be manipulated

Display/Operation Type		AT		SP NO.		GROUP NO.	
		Dsp.	Opr.	Dsp.	Opr.	Dsp.	Opr.
Control mode							
Single loop		Yes	Yes*	Yes	Yes	Yes	Yes
Cascade	Primary	Yes	Yes*	Yes	Yes	Yes	Yes
	Secondary	Yes	Yes*	Yes	Yes	Yes	Yes
PV switching		Yes	Yes*	Yes	Yes	Yes	Yes

* Not displayed in the soft key menu if [Control] > [#1 Control action, Input setting] > [Auto tuning] is set to [OFF].

In addition, there are conditions in which certain soft keys appear, but their operation is not possible. The table below shows the conditions and corrective action specific to the tuning display. For the conditions and corrective actions that are common with the control display, see "Display and Operation on the Control Display and Control Mode" on *page 6-6*.

Condition in Which Operation Is Not Possible	Corrective Action
When auto tuning is already in progress	Abort the auto tuning operation in progress.
Mode other than auto operation mode and loop other than the primary loop of cascade control	Switch the auto operation mode
Primary loop of cascade control and the secondary loop are not set to cascade mode	Switch to cascade mode
Operation stopped	Start the Operation
When "A/D error" or "burnout error" occurs at the input.	Resolve the cause of the error

- Error messages for the operations above
 - When auto tuning is in progress: Auto-tuning is activated already.
 - Others: Auto-tuning cannot be activated.

6.4 Operations on the Program Selection Display and Program Control Display (Only on Models with the Program Control Option)

This section explains the operations that you can perform on the program selection display and the program control display on models with the program control option. The program selection display enables you to confirm program patterns and switch pattern numbers; the program control display enables you to control programs such as run, reset, and hold as well as monitor the control status.

Procedure

Displaying the Program Selection Display

On the control group display or control overview display, select [CONTROL] > [PROGRAM] from the screen selection menu (see page 6-1.)

Displayed Information and Operations on the Program Selection Display

Display of time per division
 ([Set mode] > [#3 Trend/Save interval > Time/div] > [Time/div] setting)

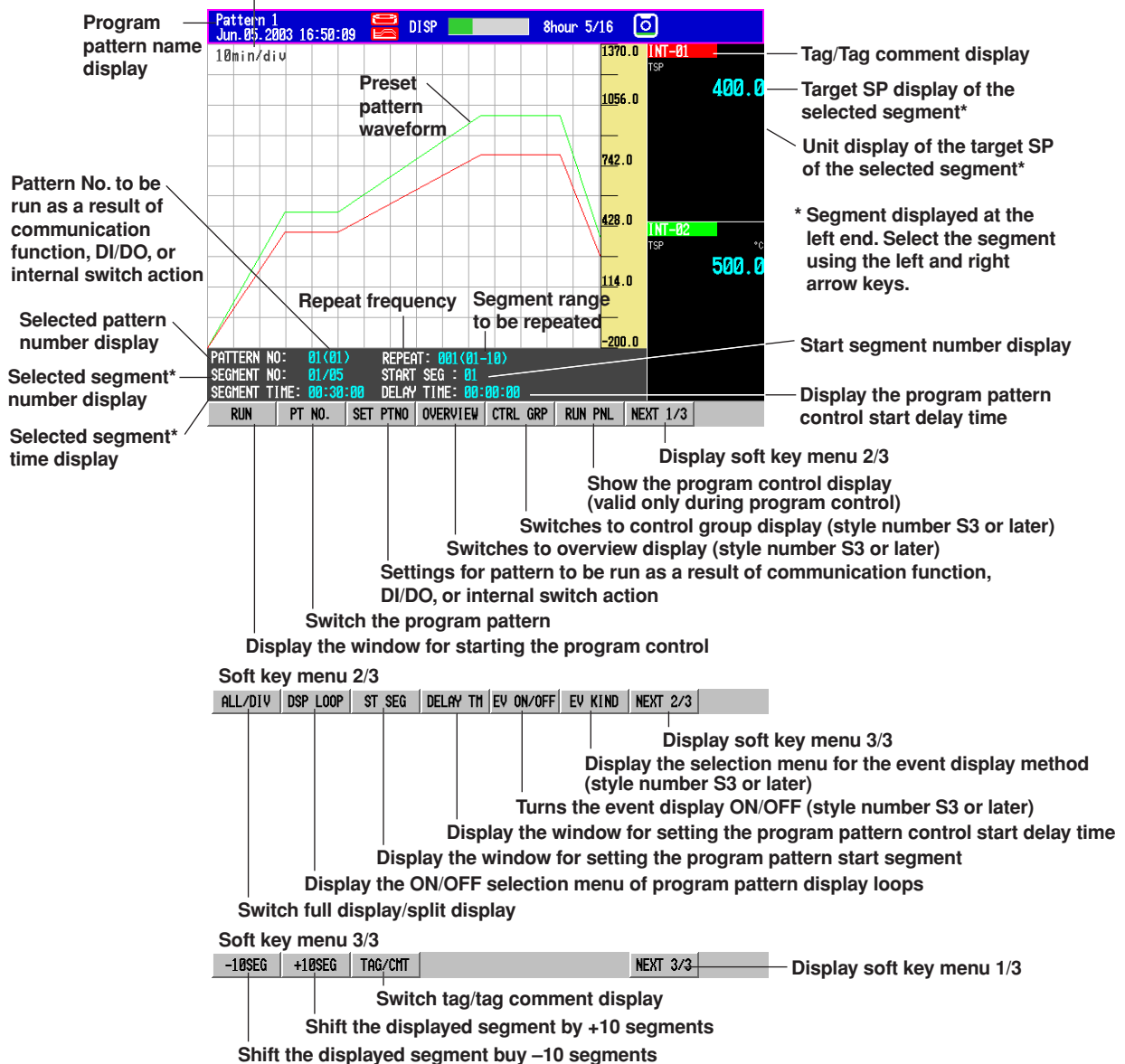

Switching the Pattern Number

1. Press the **[PT NO.] soft key**.
A pop-up window for switching the pattern number appears. The window shows the current pattern number.

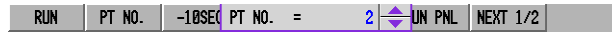

2. Select the pattern number using the up and down arrow keys.
3. Press the **DISP/ENTER** key to confirm the changes.
To close the window without making any changes, press the ESC key.

Setting Operation for Patterns That Start by Communications Command, DI/DO, or Internal Switches (Style Number S3 Or Later)

1. Press the **[SET PTNO.] soft key**.
The pattern number (the same number as the pattern number that can be started from this screen) selected by the PT NO. soft key above is set.
Even if you change the pattern number with the PT NO. soft key, if you do not press the SET PTNO soft key, the pattern numbers that start by communication commands, DI/DO/internal switches are not changed.

Switching to the Overview Screen (Style Number S3 or Later)

1. Press the **[OVERVIEW] soft key**.
Among the loops of the displayed program patterns, the screen switches to the overview screen including loops with small numbers.

Switching to the Control Group Screen (Style Number S3 or Later)

1. Press the **[CNTRL GRP] soft key**.
Among the loops of the displayed program patterns, the screen switches to the group's control group screen including loops with small numbers.

Selecting Segments

- Press the **left and right arrow keys**.
The displayed pattern waveform shifts horizontally by one segment. The [SEGMENT NO], [SEGMENT TIME], and the target SPs of each group corresponding to the segment shown at the left end are displayed.
- To shift 10 segments at a time, press the **[+10SEG]** or **[-10SEG] soft key**.
- Press the **up arrow key** to show the pattern waveform overview window as shown in the figure below. You can select segments (as described above) while showing this pattern waveform overview window. To close the pattern waveform overview window, press the **down arrow key**.

Indicates the pattern waveform display area (move using the left and right arrow keys) using a rectangular frame

Display of the segment number/segment time at the left frame line position

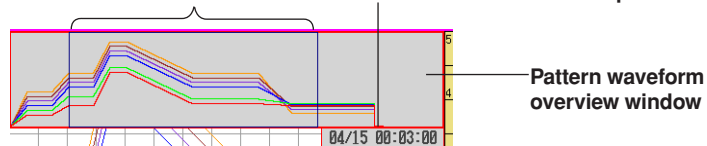

6.4 Operations on the Program Selection Display and Program Control Display (Only on Models with the Program Control Option)

Turning ON/OFF the Pattern Waveform Display of Each Loop

1. Press the **[DSP LOOP]** soft key.

A menu used to turn ON/OFF the pattern waveform display appears. The soft keys of each loop show the tag names of each loop ([INT-01] to [INT-06] in the figure below).

INT-01	INT-02	INT-03	INT-04	INT-05	INT-06	BACK	
--------	--------	--------	--------	--------	--------	------	--

2. Press the **soft key** corresponding to the tag name of the loop you wish to turn ON/OFF.

INT-01	INT-02	INT-03	INT-01 =	OFF	INT-06	BACK	
--------	--------	--------	----------	-----	--------	------	--

3. Select [ON] or [OFF] using the **up and down arrow keys**.
4. Press the **DISP/ENTER** key to confirm the changes.
To close the window without making any changes, press the ESC key.
Press the [BACK] soft key to return to the original soft key menu.

Starting Program Control

1. Press the **[RUN]** soft key.

A pop-up window for starting the program control appears.

RUN	PT NO.	SET PTH	RUN =	RUN	UN PNL	NEXT 1/3	
-----	--------	---------	-------	-----	--------	----------	--

2. Press the **DISP/ENTER** key.

Selecting the Program Pattern Start Segment

1. Press the **[NEXT 1/3]** soft key.
2. Press the **[ST SEG]** soft key.

A pop-up window for selecting the start segment appears.

ALL/DIV	DSP LOOP	ST SEG	ST SEG =	1	V KIND	NEXT 2/3	
---------	----------	--------	----------	---	--------	----------	--

3. Select the segment number using the **up and down arrow keys**.
4. Press the **DISP/ENTER** key.

Setting the Delay Time for Starting the Program Pattern Control

1. Press the **[NEXT 1/3]** soft key.
2. Press the **[DELAY TM]** soft key.

A pop-up window for setting the delay time appears.

ALL/DIV	DSP LOOP	ST SEG	DELAY TH=	00:00:00	V KIND	NEXT 2/3	
---------	----------	--------	-----------	----------	--------	----------	--

3. Change the delay time using the **up and down arrow keys**.
4. Press the **DISP/ENTER** key.

6.4 Operations on the Program Selection Display and Program Control Display (Only on Models with the Program Control Option)

Event Display Operation (Style Number S3 or Later)

1. Press the **[Next 1/3]** soft key.
2. Press the **[EV ON/OFF]** soft key.
Time events and PV events are displayed.

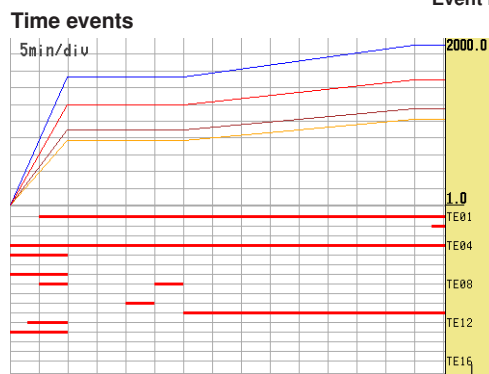
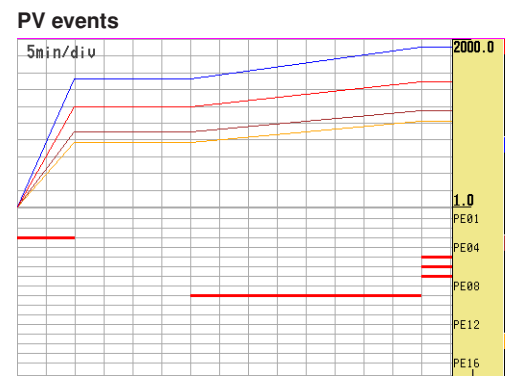
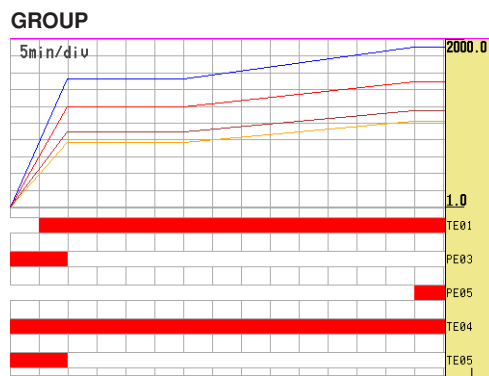
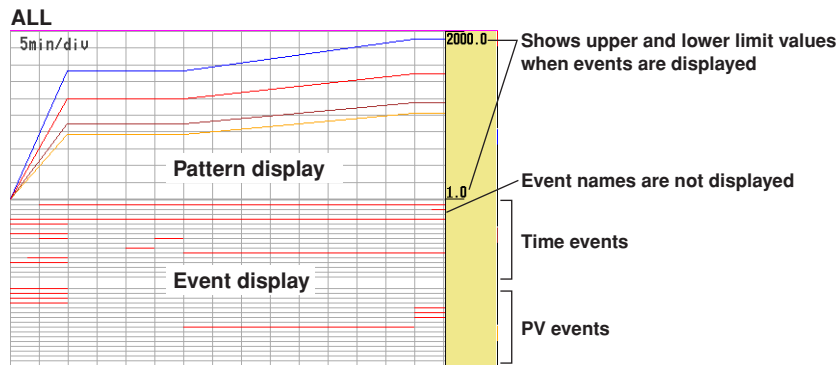

Event names

One part event names

One part event names

3. Press the **[EV KIND]** soft key.
A pop-up window for selecting event to be displayed appears.
- ALL/DIV DSP LOOP ST SEC EV KIND = GROUP V KIND NEXT 2/3
4. Set the events to be displayed using the **up and down arrow keys**.
 5. Press the **DISP/ENTER** key.

6.4 Operations on the Program Selection Display and Program Control Display (Only on Models with the Program Control Option)

Displayed Information and Operations on the Program Control Display

Display of time per division
 ([Set mode] > [#3 Trend/Save interval > Time/div] > [Time/div] setting)

Program pattern name display

PV waveform (solid line)*

Preset pattern waveform (dotted line)

Control pattern number display

Control segment number display

Control mode display

Tag/Tag comment display

PV, SP, and OUT display

Cursor indicating the program execution position

Displays wait time when in wait mode

Repeat frequency and repeat count values

Repeat segment range

Remaining time display of the control segment

STATUS: RUN
 PATTERN NO.: 02
 SEGMENT NO.: 04/15
 SEGMENT TIME: 00:00:19
 REPEAT: 001/001(01-10)

1min/div

55min 3/16

1370.0
 1056.0
 742.0
 428.0
 114.0
 -200.0

INT-01
 PV: 836.2 °C
 SP: 900.0 °C
 OUT: 76.3 °C

INT-02
 PV: 891.0 °C
 SP: 950.0 °C
 OUT: 18.4 °C

INT-03
 PV: 757.4 °C
 SP: 800.0 °C
 OUT: 100.0 °C

INT-04
 PV: 811.9 °C
 SP: 850.0 °C
 OUT: 21.2 °C

INT-05
 PV: 693.2 °C
 SP: 850.0 °C
 OUT: 100.0 °C

INT-06
 PV: 728.5 °C
 SP: 750.0 °C
 OUT: 100.0 °C

RUN/RST ADVANCE HOLD OVERVIEW CTRL GRP SEL PNL NEXT 1/2

HOLD (blinking): Hold mode
 WAIT: Wait mode
 DELAY: Program pattern controlled being delayed

Advance the program
 Hold the program
 Switch to overview display (style number S3 or later)
 Switch to control group display (style number S3 or later)
 Display soft key menu 2/2
 Show the program selection display

* PV waveforms are displayed when you press the START key to start the data acquisition to the internal memory.

Soft key menu 2/2

ALL/DIV	DSP LOOP	TAG/CMT	EV ON/OFF	EV KIND	NEXT 2/2
---------	----------	---------	-----------	---------	----------

Display soft key menu 1/2
 Display the selection menu for the event display method (style number S3 or later)
 Turn the event display ON/OFF(style number S3 or later)
 Switch tag/tag comment display
 Display the ON/OFF selection menu of program pattern display loops
 Switch full display/split display

Soft key menu when in hold mode

RUN/RST	ADVANCE	HOLD	SEG TIME	TSP CHG	SEL PNL	NEXT 1/3
---------	---------	------	----------	---------	---------	----------

Display the menu for selecting the loop of which the target SP is to be changed
 Display the window for changing the remaining segment time

OVERVIEW	CTRL GRP	ALL/DIV	DSP LOOP	TAG/CMT	EV ON/OFF	NEXT 2/3
----------	----------	---------	----------	---------	-----------	----------

EV KIND	NEXT 3/3
---------	----------

Running and Resetting Program Control

- Press the **[RUN/RST]** soft key.
A pop-up window for running and resetting the program control appears.
- Select [RUN] or [RESET] using the **up and down arrow keys**.
- Press the **DISP/ENTER** key to confirm the changes.
To close the window without making any changes, press the ESC key.

Advancing Segments

- Press the **[ADVANCE]** soft key.
A pop-up window for advancing segments appears.

RUN/RST	ADVANCE	HOLD	ADVANCE =	GO	EL PNL	NEXT 1/2
---------	---------	------	-----------	----	--------	----------
- Press the **DISP/ENTER** key to execute the advance operation.
To cancel the operation, press the ESC key.

Executing and Releasing the Hold Operation

1. Press the **[HOLD] soft key**.
A pop-up window for executing/releasing the hold operation appears.

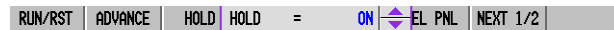

2. Select [ON] (execute) or [OFF] (release) using the **up and down arrow keys**.
3. Press the **DISP/ENTER key** to confirm the changes.
To close the window without making any changes, press the ESC key.

Changing the Remaining Segment Time When in Hold Operation

1. Press the **[SEG TIME] soft key**.
A pop-up window for changing the remaining segment time appears. The window shows the remaining segment time.

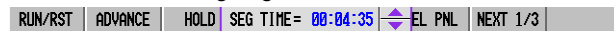

2. Change the remaining segment time using the **up and down arrow keys**.
3. Press the **DISP/ENTER key** to confirm the changes.
To close the window without making any changes, press the ESC key.

Changing the Target SP When in Hold Operation

1. Press the **[TSP CHG] soft key**.
A menu for selecting the loop of which the target SP is to be changed appears. The soft keys of each loop show the tag names of each loop ([INT-01] to [INT-06] in the figure below).



2. Press the **soft key** corresponding to the tag name of the loop you wish to change the target SP.
A pop-up window for changing the target SP appears. The window shows the current target SP.

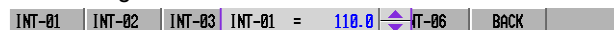

3. Change the target SP using the **up and down arrow keys**.
4. Press the **DISP/ENTER key** to confirm the changes.
To close the window without making any changes, press the ESC key.
Press the [BACK] soft key to return to the original soft key menu.

Turning ON/OFF the Pattern Waveform Display of Each Loop

The operation is the same as program selection display. For the operating procedure, see page 6-12.

Event Display Operation (Style Number S3 or Later)

The operation is the same as program selection display. For the operating procedure, see page 6-13.

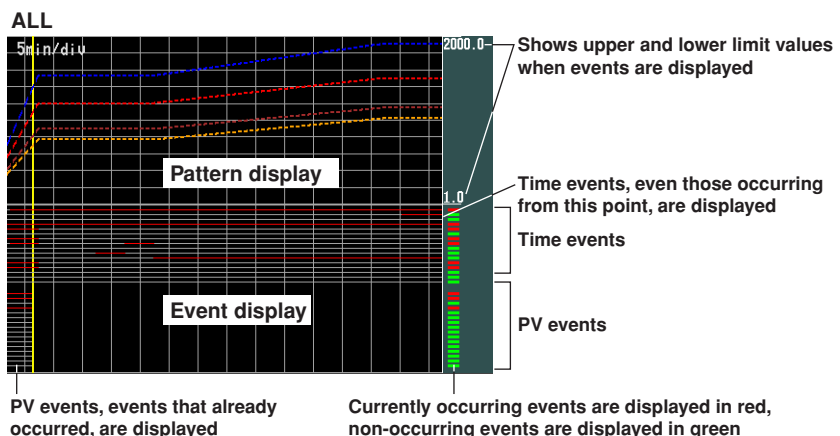

6.4 Operations on the Program Selection Display and Program Control Display (Only on Models with the Program Control Option)

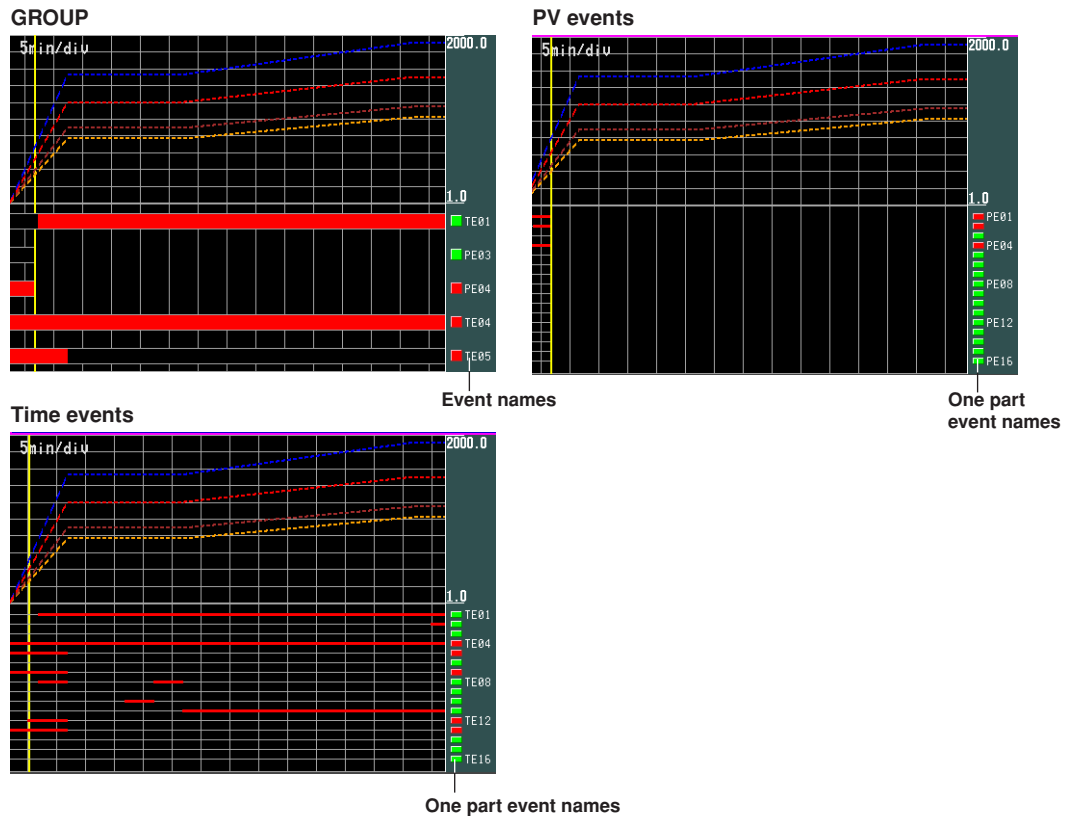

Executing Several Program Patterns

You can execute multiple program patterns whose loop numbers do not overlap.

Switching Pattern Numbers (see page 6-13)

1. Press the **[PT NO.] soft key** in the program selection screen.
The pattern number switching pop-up window appears. The currently set pattern numbers are displayed in the window.
2. Select a pattern number using the **up and down arrow keys**.
3. Press **DISP/ENTER key** to confirm the changed settings.
To close without saving, press the ESC key.

Program Operation Start

1. Press the **[RUN] soft key**.
The program operation start pop-up window appears.
2. Press the **DISP/ENTER key**. The screen changes to the program operation display.

Displaying the Program Selection Display

1. Press the **[SEL PNL] soft key**.
The screen changes to the program selection display.

Executing a Separate Program Pattern

1. Repeat the above procedure as necessary.

Switching the Displayed Pattern in the Program Operation Display

1. Press the **left or right arrow keys** to switch the displayed pattern.

Switching from the Screen Selection Menu

1. Press **DISP/ENTER key** in the program operation display to display the display selection menu.
2. With Control selected, press the **Right arrow key** to display a submenu.
3. Press the **up and down arrow keys** to select the pattern to display.
4. Press the **DISP/ENTER key** to display the selected pattern.

Explanation

Starting Program Control

Start program control by displaying the program selection display, selecting the pattern number ([PT NO.] soft key), and starting the control ([RUN] soft key). You can only start the program control on the program selection display.

When you start the program control, the program selection display switches to the program control display. On the program control display, run and reset the program control using a pop-up window that appears by pressing the [RUN/RESET] soft key.

Selecting the Program Pattern Start Segment

If you wish to set the program control start segment to a value other than [1], select the start segment number using a number within [Segments]. Set the value on the program selection display before program control. The value is reset to [1] when you reset the program control.

Setting the Delay Time for Starting the Program Pattern Control

If you wish to delay the starting of the program pattern control by a specified time, set the time from program control start to program pattern control in the range of [00:00:00] to [99:59:59]. Set the value on the program selection display before program control. The value is reset to [00:00:00] when you reset the program control.

Operation Mode during Program Control

The following operation modes are available during program control. Of the operations shown in the figure below, [RUN/STOP] and [PRG/LOG] switch operations are carried out on the control group display. For these operations, see section 6.1, "Operations on the Control Group Display (Switching Displayed Information and Control Operation Modes)."

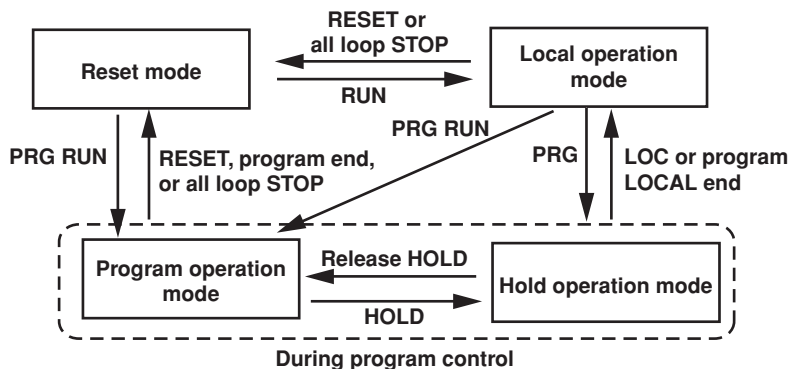

In the figure, "reset mode" refers to the status in which the program control of all loops is stopped. When program control is started, all loops enter "program control mode." When in "reset mode," you cannot set specified loops to "program control mode." However, you can switch specified loops to "local mode" or stop the operation after program control is started. In addition, even when certain loops are in "local mode," the operation of all loops stops when you set "reset mode."

Display Update Rate on the Program Control Display

The update rate of the waveform section follows the settings specified by [Set mode] > [#3 Trend/Save interval, Message, File, USER key, DST] > [Time/div]. The update rate of other information is 1 s.

Note

If the segment time is set considerably smaller than the waveform display update rate (such as "30 min/div" for the waveform display update rate and "10 s" for the segment time), segments cannot be displayed on the pattern waveform display due to the limitation of the display resolution. Use caution when the segment time is set short.

6.4 Operations on the Program Selection Display and Program Control Display (Only on Models with the Program Control Option)

Displayed Preset Pattern Waveforms and Their Display Color

Only the preset pattern waveforms of loops that are set as follows are displayed: [Control] > [#1 Control action, Input setting] > [Control mode] to a mode other than [Off] and [Program control] to [On]. If cascade control loops are present, the secondary loops are not displayed. The pattern waveform colors are red, green, blue, blue-violet, brown, and orange for loops 1 to 6, respectively.

Turning ON/OFF Preset Patterns and PV Waveforms

If viewing is difficult due to overlapping waveforms or if you wish to monitor only certain loops, you can turn OFF the display of unneeded waveforms. For loops of which the waveform display is turned OFF, the background color (waveform color) of the tag/tag comment display in the numeric display section disappears.

When waveform display of 2, 4, 5, and 6 are turned OFF

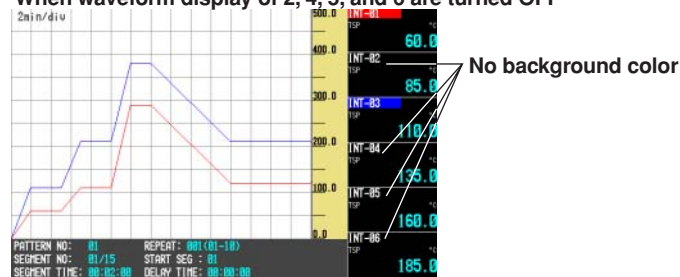

Split Waveform Display on the Program Selection Display and Program Control Display

If viewing is difficult due to overlapping waveforms on the full display, you can divide the display area into sections. The waveform display position of each loop in split display is set using [setting mode (control)] > [#7 Program-control parameters] > [#3 AUX (Auto message, Display position)] > [Program display position]. For the procedure, see *section 5.9, "AUX (Auto message, Display position)."* The figure below shows an example in which the display area is divided into three sections.

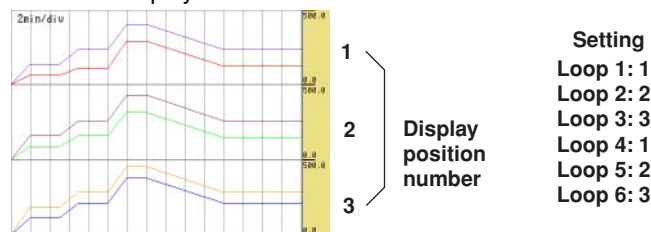

Note

The scale displayed at the right edge of the waveform display section on the full display is the scale corresponding to the smallest numbered loop. On the split display, the scale is that of the smallest numbered loop in the divided area.

Changing the Pattern Settings When in Hold Operation

You can change the following settings when in hold operation.

- The remaining time of the current segment
- Target SPs of each loop

When in hold operation, the soft key menu shows [SEG TIME] (display a window for changing the remaining segment time) and [TSP CHG] (display a menu for selecting the loop of which the target SP is to be changed).

Behavior of the Cursor Indicating the Program Execution Position

- Before program control is started, the cursor is at the left end of the waveform display section.
- After program control is started, the cursor moves to the right and indicates the program execution position.
PV waveforms are not displayed until you press the START key to start the data acquisition to the internal memory.
- After the cursor moves near the center of the waveform display section, the cursor display position stops and the waveforms move. This is to display both the past and future sections of the waveforms.
- When the pattern end is neared, the cursor moves to the right.
- When the pattern ends, the cursor is at the right end of the waveform display section.

Display When in Hold/Wait Operation and When Released

- When program control is in hold or in wait status, segment time stops and the preset pattern waveform no longer moves. However, PVs continue to be updated.
- When program control hold or wait is released, waveforms are redrawn for the past section based on the PVs and SPs. For the future section, waveforms are redrawn based on the pattern settings. If the pattern is changed while program operation is held, the corresponding preset pattern is redrawn.

Event Display (Style Number S3 or Later)

- The screen splits into the program selection and program operation displays, and displays events. You can select an event display method from the following.
 - GROUP: The 5 events and event names specified for the group are displayed.
 - TIME EV: All time events and representative event names are displayed.
 - PV EVENT: All PV events and representative event names are displayed.
 - ALL: All events are displayed
- In the program operation display, time events scheduled from the current time are displayed.
- In the program operation display, the indicators that show whether events are ON or OFF are displayed.
 - ON: Displays in red
 - OFF: Displays in green
- When displaying events, waveform division display is unavailable.
- Shows upper and lower limit scale values only when events are displayed

Display during Advance

When the [ADVANCE] soft key is pressed, the remaining segment time is cleared, and the program moves to the beginning of the next segment. Accordingly, the future section of the displayed preset pattern is shifted by an amount of the lost remaining segment time.

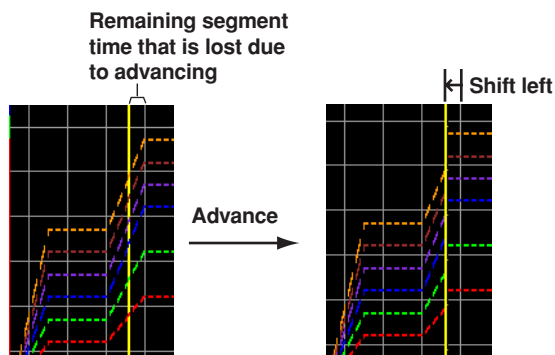

Executing Multiple Program Patterns

You can run a program pattern when another program pattern is running. Patterns having overlapping loops may not be run simultaneously.

7.1 Settings Related to Measurement Inputs

This section explains how to set parameters related to measurement input of the measurement function such as A/D integral time, scan interval, and range.

Procedure

Opening the Setting Display

- **When Setting the A/D Integral Time, Scan Interval, Etc.**

Burn out and RJC settings cannot be entered on 0 measurement channel models (the setting menu is not displayed).

Press the keys in the following sequence:

MENU key (switch to the Setting mode (Control)) > **Hold down the FUNC key for 3 seconds** (switch to basic setting mode) > **#1 soft key** (select [Alarm, A/D, Temperature])

The following display appears.

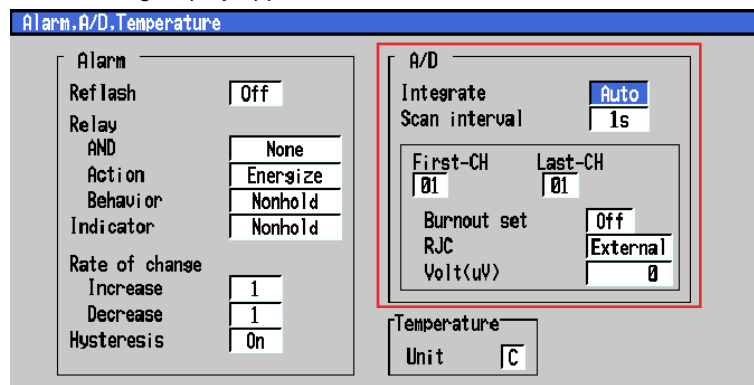

- **When Setting the Range**

Range settings cannot be entered on 0 measurement channel models. An error message will appear if the range or alarm setting screen is selected.

Press the keys in the following sequence:

MENU key (switch to the Setting mode (Control)) > **MENU key** (switch to the Set mode) > **#1 soft key** (select [Range, Alarm])

The following display appears.

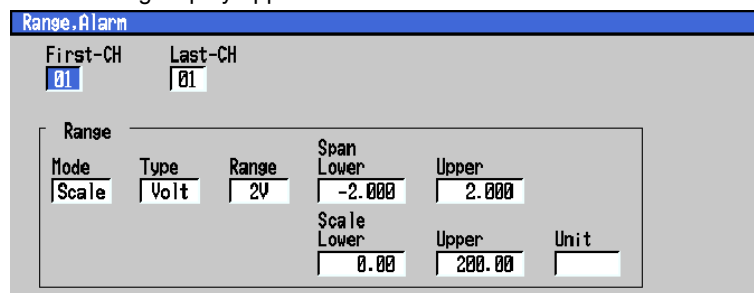

7.1 Settings Related to Measurement Inputs

- **When Setting the Moving Average**

The moving average setting cannot be entered on 0 measurement channel models (the setting menu is not displayed).

Press the keys in the following sequence:

MENU key (switch to the Setting mode (Control)) > **MENU key** (switch to the Set mode) > **#2 soft key** (select [Tag, Moving average, Alarm delay])

The following display appears.

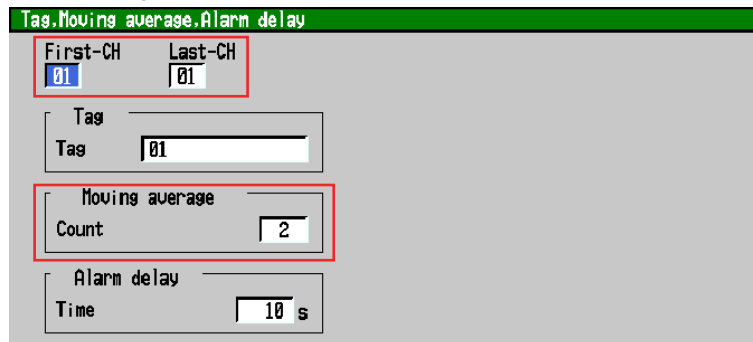

Setup Procedure

1. Use the **arrow keys** to move the cursor (blue) to the item box you wish to change. A soft key menu is displayed at the bottom of the display.
2. Press the **soft key** corresponding to the value you wish to select. The box for the item you changed turns yellow, and the cursor moves to the next item.
3. Repeat steps 1 and 2 to change the value of all the items you wish to change.

Note

The value is set using the pop-up window that appears by pressing the [Input] soft key.

4. Press the **DISP/ENTER key** to confirm the changes. The boxes for the items you changed turn from yellow to white, and the cursor returns to the first item box.

Saving the Settings in Basic Setting Mode

1. Press the **ESC key**. The display returns to basic setting menu.
2. Press the **[End] soft key**. A confirmation dialog box appears.
3. Select [Yes] and press the **DISP/ENTER key**. The operation screen is displayed.

Setup Items

Setting the A/D Integral Time, Scan Interval, Etc.

- **Integrate** (common to the control input and measurement input)
Select the integral time of the A/D converter. Select from [Auto], [50Hz], [60Hz], and [100ms].
Auto: The CX2000 automatically detects the power supply frequency and switches between 16.7 ms (60 Hz) or 20 ms (50 Hz).
50Hz: The integral time is fixed to 20 ms.
60Hz: The integral time is fixed to 16.7 ms.
100ms: The integral time is fixed to 100 ms (the scan interval is 2 s).
- **Scan interval**
You can select [1s] or [2s]. However, if Integrate is set to [100ms], the scan interval is fixed to [2s] ([1s] cannot be selected).

- **First-CH/Last-CH**

Select the range of channels for setting the burnout and RJC.

- **Burnout set**

Set the burnout action for the measurement inputs. Select [Off], [Up], or [Down] (initial value is Off). This setting is valid only for thermocouple inputs.

Off: Burnout action Off

Up: When the thermocouple burns out, the measured result is set to positive overflow “+*****.”

Down: When the thermocouple burns out, the measured result is set to negative overflow “-*****.”

- **RJC**

This is the reference junction compensation setting for thermocouple inputs. Select either [Internal] or [External] (initial value is Internal). This setting is valid only for thermocouple inputs.

Internal: Uses the reference junction compensation function of the CX2000.

External: Uses the external reference junction compensation function.

If set to [External], a box for entering the reference junction compensation voltage that is to be added to the input appears. Set the value in the range of [-20000] μ V to [20000] μ V (initial value is 0 μ V).

Setting the Range

- **First-CH/Last-CH**

Select the range of measurement channels for setting the range. On models with 10 measurement inputs, select from [01] to [10]; on models with 20 measurement inputs, select from [01] to [20].

- **Range**

First, select the input mode in the [Mode] entry box from [Volt], [TC], [RTD], [DI], [Delta], [Sqrt], and [Scale]. Then, set other parameters such as [Range], [Span Lower/Upper] according to the selected input mode as described below. Set [Skip] for channels that are not to perform measurements or displays.

- When set to [Volt] input

Range	Selectable Measurement Span Range
20mV	-20.00 to 20.00 mV
60mV	-60.00 to 60.00 mV
200mV	-200.0 to 200.0 mV
2V	-2.000 to 2.000 V
6V	-6.000 to 6.000 V
20V	-20.00 to 20.00 V
50V	-50.00 to 50.00 V

Note

For current inputs, a shunt resistor is attached to the input terminal to convert the signal to voltage input. The following table shows the available shunt resistors. For example, a 250- Ω shunt resistor is used to convert the signal in the range of 1 to 5 V for 4-20 mA input.

Name	Model	Resistance
Shunt resistor	4159 20	250 Ω \pm 0.1%
(for screw terminals)	4159 21	100 Ω \pm 0.1%
	4159 22	10 Ω \pm 0.1%

7.1 Settings Related to Measurement Inputs

- When set to [TC] (thermocouple input)

Range	Selectable Measurement Span Range
R	0.0 to 1760.0 °C
S	0.0 to 1760.0 °C
B	0.0 to 1820.0 °C
K	-200.0 to 1370.0 °C
E	-200.0 to 800.0 °C
J	-200.0 to 1100.0 °C
T	-200.0 to 400.0 °C
N	0.0 to 1300.0 °C
W	0.0 to 2315.0 °C
L	-200.0 to 900.0 °C
U	-200.0 to 400.0 °C
PLATI	0.0 to 1400.0 °C
PR	0.0 to 1900.0 °C
WRe	0.0 to 2400.0 °C

- When set to RTD (resistance temperature detector)

Range	Selectable Measurement Span Range
Pt100	-200.0 to 600.0 °C
JPt100	-200.0 to 550.0 °C

- When set to [DI] (ON/OFF input)

Range	Selectable Measurement Span Values
Level	0: Less than 2.4 V, 1: Greater than or equal to 2.4 V
Cont	0: Open, 1: Closed

- When set to [Delta] (difference computation)

Type	Range	Selectable Measurement Span Range
Voltage	20mV	-20.00 to 20.00 mV
	60mV	-60.00 to 60.00 mV
	200mV	-200.0 to 200.0 mV
	2V	-2.000 to 2.000 V
	6V	-6.000 to 6.000 V
	20V	-20.00 to 20.00 V
	50V	-50.00 to 50.00 V
	TC	R
S		-1760.0 to 1760.0 °C
B		-1820.0 to 1820.0 °C
K		-1570.0 to 1570.0 °C
E		-1000.0 to 1000.0 °C
J		-1300.0 to 1300.0 °C
T		-600.0 to 600.0 °C
N		-1300.0 to 1300.0 °C
W		-2315.0 to 2315.0 °C
L		-1100.0 to 1100.0 °C
U		-600.0 to 600.0 °C
PLATI		-1400.0 to 1400.0 °C
PR		-1900.0 to 1900.0 °C
WRe		-2400.0 to 2400.0 °C
RTD	Pt100	-800.0 to 800.0 °C
	JPt100	-750.0 to 750.0 °C
DI	Level	-1 to 1
	Cont	-1 to 1

Note

- Relationship with the reference channel
Even if the input types (Volt, TC, RTD, or DI) or the measurement ranges between the difference computation channel and reference channel are not the same, the difference computation is performed according to the following rules.
 - If the number of digits to the right of the decimal is different between the reference channel and the difference computation channel, the number of digits to the right of the decimal of the measured value of the reference channel is matched to that of the difference computation channel, and the difference is computed.
Example: If the measured value of the difference computation channel is 10.00 and the measured value of the reference channel is 100.0, the computed result is $10 - 100.0 = -90.00$.
 - If the units between the reference channel and the computation channel differ, unit correction is not performed.
Example: If the measured value of the difference computation channel is 10.00 mV and the measured value of the reference channel is 5.00 mV, the computed result is $10.00 \text{ V} - 5.00 \text{ mV} = 5.00 \text{ V}$.
 - If the [Mode] of the reference channel is set to [Scale] or [Sqrt], the scale value is used for the computation.

- When set to [Scale]
Select this mode when scaling the measured value to a value in an appropriate unit for the measurement. Select the type (input type) from [Volt], [TC], [RTD], and [DI]. Then, set [Range], [Span Lower/Upper], as well as [Scale Lower/Upper] and [Unit] after the conversion. The selectable [Range] is the same as when other inputs are selected with the mode. The selectable range of [Scale] is [-30000] to [30000]. The decimal point position can be set to "X.XXXX," "XX.XXX," "XXX.XX," "XXXX.X," or "XXXXX." The decimal point position is determined by the [Scale Lower] setting.

Note

The CX2000 converts the measured value to a value obtained by removing the decimal point from the value range specified by [Scale Lower] and [Scale Upper]. In other words, if the [Scale] setting is [-5] to [5], the value is converted to a value within the span of "10"; if the [Scale] setting is [-5.0] to [5.0], the value is converted to a value within a span of "100." In this case, the resolution of the value converted to a span of "10" is lower than the value converted to a span of "100." To prevent the display from becoming coarse, set the [Scale] setting so that this value is greater than 100 as much as possible.

- When set to [Sqrt] (square root computation)
Select this mode when computing the square root of the DC voltage input and converting the computed result to a value with an appropriate unit for displaying. Select the input range from [20mV], [60mV], [200mV], [2V], [6V], [20V], and [50V]. Then, set [Span Lower/Upper] (measurement span) of the input as well as [Scale Lower/Upper] and [Unit] after the conversion. The selectable range of [Scale] is [-30000] to [30000]. The decimal point position can be set to "X.XXXX," "XX.XXX," "XXX.XX," "XXXX.X," or "XXXXX." The decimal point position is determined by the [Scale Lower] setting.

Note

- You cannot set the same value to [Scale Lower] and [Scale Upper].
- The CX2000 converts the measured value to a value obtained by removing the decimal point from the value span specified by [Scale Lower] and [Scale Upper]. In other words, if the [Scale] setting is [-5] to [5], the value is converted to a value within the span of "10"; if the [Scale] setting is [-5.0] to [5.0], the value is converted to a value within a span of "100." In this case, the resolution of the value converted to a span of "10" is lower than the value converted to a span of "100." To prevent the display from becoming coarse, set the [Scale] setting so that this value is greater than 100 as much as possible.

Setting the Moving Average

- First-CH/Last-CH**
Select the range of channels for setting the moving average.
- Moving average**
Select the sampling data count of the moving average from [2] to [16].

7.2 Settings Related to Measurement Alarms

This section explains how to set alarm-related parameters such as alarm output ON/OFF, alarm output type, and alarm delay, and how to clear the alarms when they occur.

Procedure

Opening the Setting Display

- **When setting the alarm output**

Alarm settings cannot be entered on 0 measurement channel models. An error message will appear if the range or alarm setting screen is selected.

Press the keys in the following sequence:

MENU key (switch to the Setting mode (Control)) > **MENU key** (switch to the Set mode) > **#1 soft key** (select [Range,Alarm])

The following display appears.

Range	
Mode	Range
Volt	2V
Span	
Lower	Upper
-2.000	2.000

Alarm						
Type	Value	Relay On/Off	Number	Detect		
1	On	H	0.000	On	I01	On
2	On	L	-1.000	On	I01	On
3	Off					
4	Off					

- **When setting the alarm delay**

The alarm delay setting cannot be entered on 0 measurement channel models (the setting menu is not displayed).

Press the keys in the following sequence:

MENU key (switch to the Setting mode (Control)) > **MENU key** (switch to the Set mode) > **#2 soft key** (select [Tag, Moving average, Alarm delay])

The following display appears.

First-CH	Last-CH
01	01

Tag
01

Moving average	
Count	2

Alarm delay	
Time	10 s

- **When setting the alarm relay output and alarm details**

Press the keys in the following sequence:

MENU key (switch to the Setting mode (Control)) > **Hold down the FUNC key for 3 seconds** (switch to basic setting mode) > **#1 soft key** (select [Alarm,A/D, Temperature])

The following display appears.

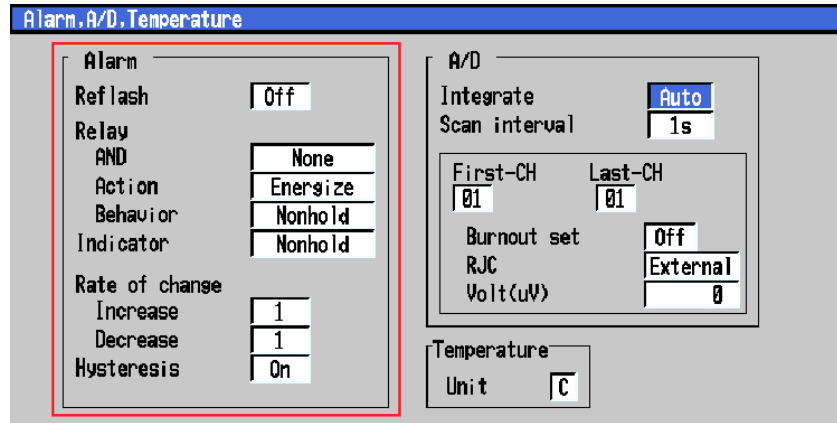

- **When setting the memory alarm**

Press the keys in the following sequence:

MENU key (switch to Set mode) > **Hold down the FUNC key for 3 seconds** (switch to basic setting mode) > **#9 soft key** (select [AUX, Time zone])

The following display appears.

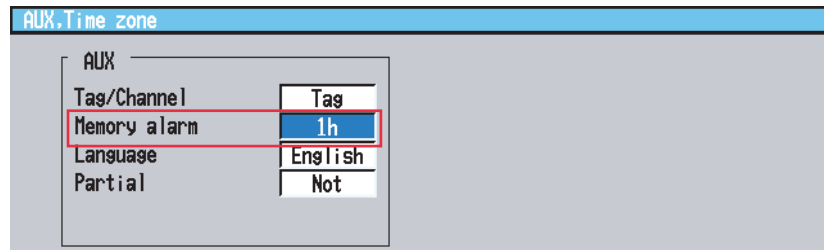

Setup Procedure

1. Use the **arrow keys** to move the cursor (blue) to the item box you wish to change. A soft key menu is displayed at the bottom of the display.
2. Press the **soft key** corresponding to the value you wish to select. The box for the item you changed turns yellow, and the cursor moves to the next item.
3. Repeat steps 1 and 2 to change the value of all the items you wish to change.

Note

The value is set using the pop-up window that appears by pressing the [Input] soft key.

4. Press the **DISP/ENTER key** to confirm the changes. The boxes for the items you changed turn from yellow to white, and the cursor returns to the first item box.

Saving the Settings in Basic Setting Mode

1. Press the **ESC key**. The display returns to basic setting menu.
2. Press the **[End] soft key**. A confirmation dialog box appears.
3. Select [Yes] and press the **DISP/ENTER key**. The operation screen is displayed.

7.2 Settings Related to Measurement Alarms

Clearing Alarms When They Occur

The following operation is valid only when [Behavior] is set to [Hold] or [Indicator] is set to [Hold].

- In operation mode, press the **FUNC key**.
A soft key menu is displayed at the bottom of the display.
- Press the **[AlarmACK] soft key**.

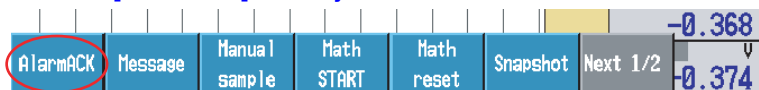

Note

- This operation can be assigned to the USER key. If it is, alarms can be cleared simply by pressing a single key. For the procedure in assigning a function to the USER key, see *section 11.1, "USER Key Assignment and Operation."*
- This operation is common with control alarms.

Setup Items

Setting the Alarm Output

Note

- Set the alarm output after setting the range.
- All alarm settings of a channel are cancelled in the following cases.
 - When the input type ([Volt], [TC], etc.) is changed.
 - When the input range is changed.
 - When the upper or lower limit of the span or scale is changed on channels that are set to scale or square root computation (including changes in the decimal point position).
 - When [Range] is set to [Skip], alarm output cannot be specified (the alarm entry box is grayed).
 - For a description on the alarm setting of computation channels, see *section 10.3, "Setting Alarms on Computation Channels."*

- First-CH/Last-CH**

Set the target channel for setting the alarm output. The target channels are common with the range setting.

- Off/On**

Up to 4 alarms can be set to a single channel. For each of the alarms [1] to [4], select [On] to enable an alarm, [Off] to disable it. If [On] is selected, [Type], [Value], and [Relay On/Off] entry boxes appear.

- Type**

Select the alarm type (conditions for activating the alarm) from the following eight types.

Name	Displayed Symbol	Description
High limit alarm	H	An alarm occurs when the measured/computed value is greater than or equal to the alarm value.
Low limit alarm	L	An alarm occurs when the measured/computed value is less than or equal to the alarm value.
Difference high limit alarm*1	h	An alarm occurs when the difference in the measured values of two channels is greater than or equal to the difference high limit alarm value.
Difference low limit alarm*1	l	An alarm occurs when the difference in the measured values of two channels is less than or equal to the difference low limit alarm value.
High limit on rate-of-change alarm*2	R	The rate-of-change of the measured values is checked over a certain interval (set using the [Increase] entry box of basic alarm settings). An alarm occurs if the rate-of-change of the measured value in the rising direction is greater than or equal to the specified value.
Low limit on rate-of-change alarm*2	r	The rate-of-change of the measured values is checked over a certain interval (set using the [Decrease] entry box of basic alarm settings). An alarm occurs if the rate-of-change of the measured value in the falling direction is less than or equal to the specified value.
Delay high limit alarm	T	An alarm occurs when the measured value remains above or equal to the alarm value for the specified delay.
Delay low limit alarm	t	An alarm occurs when the measured value remains below or equal to the alarm value for the specified delay.

*1 Can only be specified on difference computation channels.

*2 Can only be specified on measurement channels.

- **Value**
Set the alarm value for the selected alarm type.
- **Relay On/Off**
Select whether relay output is enabled [On] or disabled [Off]. If [On] is selected, the [Number] entry box appears.
- **Number**
Set the alarm output relay number. When outputting the relay from the [ALARM] terminal of the measurement alarm option terminal block (/A6, /A6R, /A4F, /A4FR), select from [I01] to [I06]. When outputting the relay from the [DIGITAL OUT] terminal of the control output terminal block, select from [DO001] to [DO006], [DO101] to [DO106], or [DO201] to [DO206]. When outputting the relay from the [DIGITAL OUT] terminal of the DIO expansion terminal block, select from [PO001] to [PO012]. For the correspondence between the output relay numbers and the positions of the terminals of the terminal blocks, see *pages 2-6 and 2-7*.
When outputting to the internal switches (SW001-SW36), select from SW001-SW036 (style number S3 or later).
- **Detection (Style Number S3 or Later)**
Select whether to display alarms (ON) or not to display alarms (OFF) when they occur. When turned OFF, they are not retained in the alarm summary.

Setting the Alarm Delay (When [Type] is set to [T] or [t])

- **First-CH/Last-CH**
Select the measurement channels for setting the alarm delay. The target channels also apply to [Tag] and [Filter] or [Moving average] settings.
- **Alarm delay**
Set the alarm delay using an integer in the range of [1] to [3600] s.

Note

- If the scan interval is 2 s and you set an odd value for the alarm delay, it will operate at “the specified period + 1 s.” Example: If the alarm delay set to 5 s, the function will operate at 6 s.
- For a description of the alarm delay setting of computation channels, see *section 10.3, “Setting Alarms on Computation Channels.”*
- You can select internal control channels and external control channels for [First-CH] and [Last-CH]. However, these channels do not have alarm outputs, and therefore the [Alarm delay] setting is not available.

Setting the Alarm Relay Output and Alarm Details

The relay action when outputting the relay from the [DIGITAL OUT] terminal of the control output terminal block is set on the setup screen in [Control] > [#4 Relay]. For the setup procedure, see *section 4.4, “Control > Relay.”*

- **Reflash**
Set whether to enable [On] or disable [Off] the reflash alarm function of the alarm relay output.
- **Relay**
 - **AND**
Select the relays that are to operate using AND logic. Set the range of relays (from the first alarm relay) to take the AND logic. All subsequent relays will be set to OR logic. Available selections are [None], [I01] (I01 only), [I01-I02] (I01 and I02), ..., [I01-I35] (I01 to I35), and [I01-I36] (I01 to I36). Only the relays that can be used on the installed measurement alarm option terminal block (/A6, /A6R, /A4F, or /A4FR option) are valid.

Note

If the reflash alarm is turned ON, [AND] setting is invalid. It is fixed to OR logic operation.

7.2 Settings Related to Measurement Alarms

- **Action**

Select whether the alarm output relay is energized [Energize] or de-energized [De_energize] when an alarm occurs.
- **Behavior**

Select one of the following output relay behaviors when the alarm condition switches from an alarm activated condition to an alarm released condition (normal condition). The setting applies to all alarm output relays. If the alarm output relay option is not installed, the setting is disabled.

 - Nonhold (initial value): Turn OFF output relay when the alarm is cleared.
 - Hold: Hold the output relay at ON until an alarm ACK operation is performed.
- **Indicator**

Select the alarm indication behavior when the alarm condition switches from an alarm activated condition to an alarm released condition from the following.

 - Nonhold (initial value): Clear the alarm indication when the alarm is cleared.
 - Hold: Hold the alarm indication until an alarm ACK operation is performed.

Note

The indicator setting also applies to control alarms.

- **Rate of change**
 - **Increase**

Select the sampling data count used to determine the interval for the high limit on rate-of-change alarm from [1] to [15].
 - **Decrease**

Select the sampling data count used to determine the interval for the low limit on rate-of-change alarm from [1] to [15].
- **Hysteresis**

Turn [On]/[Off] the alarm hysteresis. If set to [On], the hysteresis is set to 0.5% of the measurement span or scale span.

Setting the Memory Alarm

- **Memory Alarm**

When using the Manual Save procedure to save data in the internal memory to an external storage medium, if the time until the internal memory becomes full reaches the entered value for the Memory Alarm Time, an e-mail report is sent. You can output a relay contact signal from the Memory End Output terminal on the terminal block for the memory alarm option. Select one of the memory alarm times below. You can turn OFF the Memory End Output function when not in use.

[1 hr] (initial setting), [2 hr], [5 hr], [10 hr], [20 hr], [50 hr], [100 hr]

Clearing Alarms (AlarmACK)

If the [AlarmACK] operation is performed, all alarm indications and relay outputs are cleared. However, this operation is invalid if the alarm indication/output relay behavior is set to [Nonhold]. The operation of clearing alarms is also possible using a remote input (see section 11.5, "Setting the Measurement Remote Inputs") or via communications (see the *DAQSTATION CX1000/CX2000 Communication Interface User's Manual*).

7.3 Setting the Temperature Unit

This section explains how to set the unit of temperature.

Procedure

Opening the Setting Display

Press the keys in the following sequence:

MENU key (switch to the Setting mode (Control)) > **Hold down the FUNC key for 3 seconds** (switch to basic setting mode) > **#1 soft key** (select [Alarm,A/D, Temperature])

The following display appears.

The screenshot shows a menu titled "Alarm, A/D, Temperature". It is divided into two main sections: "Alarm" and "A/D".

- Alarm Section:**
 - Ref flash: Off
 - Relay: None
 - Action: Energize
 - Behavior: Nonhold
 - Indicator: Nonhold
 - Rate of change:
 - Increase: 1
 - Decrease: 1
 - Hysteresis: On
- A/D Section:**
 - Integrate: Auto
 - Scan interval: 1s
 - First-CH: 01
 - Last-CH: 01
 - Burnout set: Off
 - RJC: External
 - Volt(uV): 0
 - Temperature Unit: C** (highlighted with a red box)

Setup Procedure

1. Use the **arrow keys** to move the cursor (blue) to the [Unit] box under [Temperature].
A soft key menu is displayed at the bottom of the display.
2. Press the **soft key** corresponding to the value you wish to select.
The box for the item you changed turns yellow, and the cursor moves to the next item.
3. Press the **DISP/ENTER key** to confirm the changes.
The box for the item you changed turns from yellow to white, and the cursor returns to the first item box.

Setup Items

Setting the Temperature Unit

- **Unit**

Set the unit of temperature to [C] (Celsius) or [F] (Fahrenheit).

8.1 Using the Information Display (Alarm Summary, Message Summary, Memory Summary, and Control Summary)

This section explains the operations that you can perform when displaying various information such as alarm summary, message summary, memory summary, and control summary.

Procedure

Switching Displayed Information

1. Press the **DISP/ENTER** key to show the display selection menu.
2. Select [INFORMATION] using the **up and down arrow keys**.
3. Press the **right arrow key** to display the sub menu.
4. Select the desired item using the **up and down arrow keys**.



5. Press the **DISP/ENTER** key to show the display for the selected item.

Switching to the Historical Trend

1. Select the item for displaying the historical trend (alarm, message, etc.) using the **up and down arrow keys**.

(003/003) Name	Type	Alarm IN Time	Alarm OUT Time
● 01	4r	2000/01/02 15:03:05	2000/01/02 15:03:06
● 01	4r	2000/01/02 15:02:59	2000/01/02 15:03:00
● 01	2L	2000/01/02 15:02:21	
● INT-01	4PVH	2000/01/02 14:53:08	
● INT-01	1PVH	2000/01/02 14:52:50	

2. Press the **DISP/ENTER** key to show the display selection menu.
3. Press the **right arrow key** to display the sub menu.
4. Select [JUMP TO HISTORY] using the **up and down arrow keys**.



5. Press the **DISP/ENTER** key to show the historical trend.
To close the menu without switching the display, press the ESC key.

Switching the Alarm Summary Display to Control Alarms Only

Perform the following operation with the alarm summary display showing.

1. Press the **DISP/ENTER** key to show the display selection menu.
2. Select [INFORMATION] using the **up and down arrow keys** and press the **right arrow key** to display the sub menu.
3. Select [ALARM (CONTROL)] using the **down arrow key**.

To set the alarm back to the original display (displaying measurement and control alarms), select [ALARM(ALL)] by performing the procedures above.



8.2 Using the Four Screen Display

This section explains the operations that you can perform when displaying four screens reduced on the display.

Procedure

Switching Display Types

1. Press the **DISP/ENTER** key twice to show the display selection menu.
2. Select [4 PANEL] using the **up and down arrow keys**.
3. Press the **right arrow key** to display the sub menu.
The display type names shown on the sub menu can be changed. For the procedure, see “Changing the Display Type Name” below.
4. Select the desired display type using the **up and down arrow keys**.

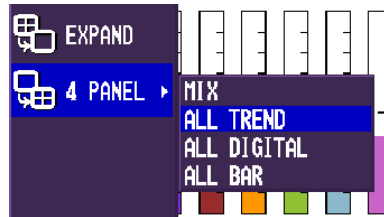

5. Press the **DISP/ENTER** key to show the display for the selected item.

Switching the Displayed Information of One of the Four Screens

1. Press the **DISP/ENTER** key.
2. Select the screen of which the displayed information is to be changed using the **up, down, left, and right arrow keys**.

The selected screen is indicated by a blue group name display section.

3. Press the **DISP/ENTER** key to show the display selection menu.
4. Select [CONTROL], [TREND], [DIGITAL], [BAR], [OVERVIEW], or [INFORMATION] using the **up, down, left, and right arrow keys**.
5. Press the **right arrow key** to display the sub menu.
6. Select the desired information using the **up and down arrow keys**.

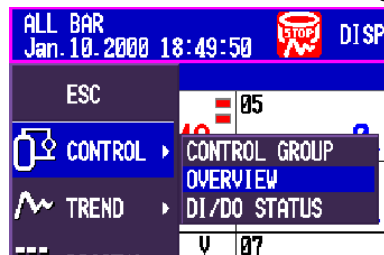

7. Press the **DISP/ENTER** key to return to the four screen display.

Changing the Display Type Name

1. Press the **FUNC** key followed by the **[4Panel]** soft key

A soft key menu used to select the display appears at the bottom of the display.

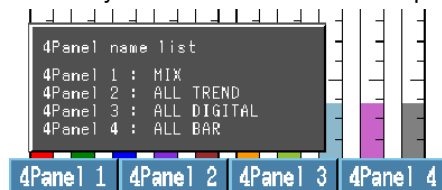

2. Select the display you wish to rename by pressing the appropriate **soft key**.
A display name entry box appears.
3. Enter the display name using the character/number input keys and soft keys.
4. Press the **DISP/ENTER** key.

8.3 Measurement Function > Measurement Group Setup Operation

This section explains how to rename the groups of trend, digital, and bar graph displays of the measurement function and how to register channels to those groups. For the operating procedures of the control groups of the control function, see *section 4.10*, "Control group setting."

Procedure

Setup Display

Press the keys in the following sequence:

MENU key (switch to setting mode(control)) > **MENU key** (switch to Set mode) > **#4 soft key** (select [Display]) > **#1 soft key** (select [Group set, Trip line])

The following display appears.

No.	On	Position	Color
1	On	100 %	Red
2	On	100 %	Green
3	On	100 %	Blue
4	On	100 %	Yellow

Setup Procedure

1. Use the **arrow keys** to move the cursor (blue) to the item box you wish to change. The selections are displayed at the bottom section of the display.
2. Press the **soft key** corresponding to the value you wish to select. The box for the item you changed turns yellow, and the cursor moves to the next item.
3. Repeat steps 1 and 2 to change the value of all the items you wish to change.

Note

The [CH set] is set using the pop-up window that appears by pressing the [Input] soft key.

4. Press the **DISP/ENTER key** to confirm the changes. The boxes for the items you changed turn from yellow to white, and the cursor returns to the first item box.

Setup Items

Renaming Groups of Trend, Digital, Bar Graph Displays of the Measurement Function and Registering Channels to Groups

- **Group number**
Select the group you wish to set from [1] to [10].
- **Group name**
Enter the group name using up to 16 alphanumeric characters.

Group name display example



8.3 Measurement Function > Measurement Group Setup Operation

- **CH set**

Select up to 10 channels from measurement channels (CH1 to CH20), computation channels (CH31 to CH60), internal control channels (CH101 to CH118), and external control channels (CH201 to CH248).

Assignment of internal control channels (channels of internal loops)

The data of 6 loops is assigned to channel numbers as follows.

Loop 1 PV: 101, Loop 1 SP: 102, Loop 1 OUT: 103

...

Loop 6 PV: 116, Loop 6 SP: 117, Loop 6 OUT: 118

Assignment of external control channels (channels of external loops)

The data of 16 loops is assigned to channel numbers as follows.

External loop 1 PV: 201, External loop 1 SP: 202, External loop 1 OUT: 203

...

External loop 16 PV: 246, External loop 16 SP: 247, External loop 16 OUT: 248

Enter the measurement/computation channels to be assigned to the selected group according to the following rules.

- Enter the channel number using two or three digits.
- Separate each channel with a period.
- Use a hyphen to specify consecutive channels.

Example: To assign CH1, CH3, CH5 to CH8, and CH101 enter "01.03.05-08.101".

8.4 Measurement Function > Settings Related to Tag Display for Channels

This section explains how to set and display tag names that can be displayed in place of channel numbers.

Procedure

Opening the Setting Display

- **Setting Tag Names That Is to Be Displayed in Place of Channel Numbers**

Press the keys in the following sequence:

MENU key (switch to setting mode(control)) > **MENU key** (switch to Set mode) >

#2 soft key (select [Tag,Moving average,Alarm delay])

The following display appears.

First-CH	Last-CH
01	01

Tag

Tag DEF

Moving average

Count Off

Alarm delay

Time 10 s

Input Clear Copy

- **Displaying Tag Names in Place of Channel Numbers**

Press the keys in the following sequence:

MENU key (switch to setting mode(control)) > **Hold down the FUNC key for 3 seconds** (switch to basic setting mode) > **#9 soft key** (select [Aux,Time zone])

The following display appears.

AUX
Tag/Channel Tag
Memory alarm 1h
Language English
Partial Not

Time zone

Difference from GMT 0

Tag Channel

Setup Procedure

1. Use the **arrow keys** to move the cursor (blue) to the item box you wish to change. A soft key menu is displayed at the bottom of the display.
2. Press the **soft key** corresponding to the value you wish to select. The box for the item you changed turns yellow, and the cursor moves to the next item.
3. Repeat steps 1 and 2 to change the value of all the items you wish to change.

Note

The tag name is set using the pop-up window that appears by pressing the [Input] soft key.

4. Press the **DISP/ENTER key** to confirm the changes. The boxes for the items you changed turn from yellow to white, and the cursor returns to the first item box.

Saving the Settings in Basic Setting Mode

1. Press the **ESC key**. The display returns to basic setting menu.
2. Press the **[End] soft key**. A confirmation dialog box appears.
3. Select [Yes] and press the **DISP/ENTER key**. The operation screen is displayed.

Setup Items

Setting Tag Names to Be Displayed in Place of Channel Numbers

• **First-CH/Last-CH**

Set the target channels. In addition to the measurement channels ([01] to [20]), internal control channels ([101] to [118]) and external control channels ([201] to [248]) can be selected for the target channels.

Assignment of internal control channels (channels of internal loops)

The data of 6 loops is assigned to channel numbers as follows.

Loop 1 PV: 101, Loop 1 SP: 102, Loop 1 OUT: 103

...

Loop 6 PV: 116, Loop 6 SP: 117, Loop 6 OUT: 118

Assignment of external control channels (channels of external loops)

The data of 16 loops is assigned to channel numbers as follows.

External loop 1 PV: 201, External loop 1 SP: 202, External loop 1 OUT: 203

...

External loop 16 PV: 246, External loop 16 SP: 247, External loop 16 OUT: 248

Note

For measurement channels, the target channels also apply to [Alarm delay] and [Filter] or [Moving average] settings.

• **Tag**

Enter the tag name using up to 16 alphanumeric characters.

Note

For the procedures of setting tag strings of measurement channels on models with the computation function option, see *section 10.1, "Assigning Computation Channels and Setting Computing Equations, Constants, and Tags."*

Displaying Tag Names in Place of Channel Numbers

• **Tag/Channel**

Select the Tag.

Note

The tag name specified here is not shown on the control loop display of the control group, control overview, tuning, and alarm summary displays. The tag name for control loops is displayed.

8.5 Measurement Function > Operations When Displaying Trend, Digital, and Bar Graph Displays

This section explains the operations that you can perform when displaying the trend, digital, or bar graph display.

Procedure

Switching Trend, Digital, and Bar Graph Displays

- **Using the Display Menu**
 1. Press the **DISP/ENTER** key to show the display selection menu.
 2. Select [Trend], [Digital], [Bar] using the **up and down arrow keys**.



- **Using Arrow Keys**

Press the down arrow key to switch the display in the following order: trend, digital, bar graph, trend, and so on. Press the up arrow key to switch the display in reverse order.

Changing the Displayed Group

- **Using the Display Menu**
 1. Press the **DISP/ENTER** key to show the display selection menu.
 2. Press the **right arrow key** to display the sub menu.
 3. Select the desired group using the **up and down arrow keys**.



4. Press the **DISP/ENTER** key to show the specified group.
- **Using Arrow Keys**

Press the right arrow key to rotate the groups among group 1 to group 4. Press the left arrow key to switch the displayed group in reverse order.
 - **Automatic Switching**
 1. Press the **DISP/ENTER** key to show the display selection menu.
 2. Press the **right arrow key** to display the sub menu.
 3. Select [AUTO SCROLL ON] using the **up and down arrow keys**.



4. Press the **DISP/ENTER key** to start the automatic switching of the groups. To disable automatic switching, select [AUTO SCROLL OFF] at step 3 and press the DISP/ENTER key.

All Channel Display on the Trend Display

1. Press the **DISP/ENTER key** to show the display selection menu. [TREND] is highlighted.
2. Press the **right arrow key** to display the sub menu.
3. Select [ALL CHANNEL] using the **up and down arrow keys**.
To set the display back to group display, select [GROUP CHANNEL] in this step.



4. Press the **DISP/ENTER key** to switch to the all channel display.

Turning ON/OFF the Scale and Numerical Display on Trend Displays

1. Press the **DISP/ENTER key** to show the display selection menu. [TREND] is highlighted.
2. Press the **right arrow key** to display the sub menu.
3. Select [SCALE ON], [DIGITAL OFF], and so on using the **up and down arrow keys**.



8.6 Measurement Function > Operations When Displaying the Overview

This section explains the operations that you can perform when displaying the overview. Overview cannot be selected on 0 measurement channel models without the calculation option installed.

Procedure

Turning OFF the Cursor

1. Press the **DISP/ENTER key** to show the display selection menu. [OVERVIEW] is highlighted.
2. Press the **right arrow key** to display the sub menu.
3. Select [CURSOR OFF] using the **up and down arrow keys**.

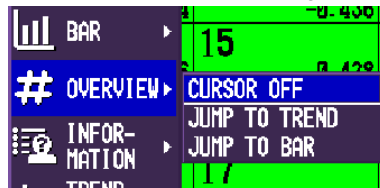

4. Press the **DISP/ENTER key** to confirm the change.

Switching to Trend Display or Bar Graph Display

1. Select the desired channel using the **arrow keys**.
2. Press the **DISP/ENTER key** to show the display selection menu. [OVERVIEW] is highlighted.
3. Press the **right arrow key** to display the sub menu.
4. Select [JUMP TO TREND] or [JUMP TO BAR] using the **up and down arrow keys**.

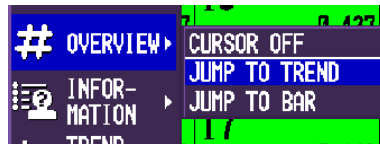

5. Press the **DISP/ENTER key** to switch to the trend or bar graph display.

8.7 Measurement Function > Operations When Displaying the Historical Trend

This section explains the operations that you can perform when displaying the historical trend. For a description on the displayed contents when the historical trend is displayed and other operations not described below, see *pages 1-78 to 1-79*.

Procedure

Zooming in or out on the Time Axis

1. Press the **DISP/ENTER** key to show the display selection menu.
[TREND HISTORY] is highlighted.
2. Press the **right arrow** key to display the sub menu.
3. Select [ZOOM +] or [ZOOM -] using the **up and down arrow** keys.



4. Press the **DISP/ENTER** key to zoom in or zoom out on the time axis.

Changing the Displayed Group on the Historical Trend Display and All Channel Display

1. Press the **DISP/ENTER** key to show the display selection menu.
[TREND HISTORY] is highlighted.
2. Press the **right arrow** key to display the sub menu.
3. To change the displayed group, select the group from [GROUP 1] to [GROUP 10] using the **up and down arrow** keys. To display all channels, select [ALL CHANNEL]. To set the display back to group display from [ALL CHANNEL], select [GROUP CHANNEL] in this step.



4. Press the **DISP/ENTER** key to switch to the all channel display.

Displaying Memory Information

1. Press the **DISP/ENTER** key to show the display selection menu.
[TREND HISTORY] is highlighted.
2. Press the **right arrow** key to display the sub menu.
3. Select [INFORMATION ON] using the **up and down arrow** keys.



4. Press the **DISP/ENTER** key to show the memory information.
To clear the displayed memory information, press the DISP/ENTER key or an arrow key.

```
File Name (Data Kind): Memory (DISP)
Serial No.           : 12A725577
Start Time          : Jan.10.2000 19:01:26
End Time           : Jan.10.2000 19:01:30
```

8.8 Measurement Function > Changing the Display Update Rate of the Trend Display

This section explains how to change the display update rate of the trend display.

Procedure

Setup Display

Press the keys in the following sequence:

MENU key (switch to Set mode) > **#3 soft key** (select [Trend/Save interval,Message,File,User key,DST])

The following display appears.

Trend/Save interval,Message,File,User key,DST

Trend/Save interval

Time/div 1min

Auto save interval 1h

Message

No.	Characters
1	
2	
3	
4	
5	
6	
7	
8	

File

Header

Directory name DATA0

User key

Action Snapshot

Daylight saving time (YY/MM/DD HH)

Summer Off

Winter Off

1min 2min 5min 10min 20min 30min Next 1/2

Setup Procedure

1. Use the **arrow keys** to move the cursor (blue) to [Time/div].
A soft key menu is displayed at the bottom of the display.
2. Press the **soft key** corresponding to the value you wish to select.
The box for the item you changed turns yellow, and the cursor moves to the next item.
3. Press the **DISP/ENTER key** to confirm the changes.
The boxes for the items you changed turn from yellow to white, and the cursor returns to the first item.

Setup Items

Setting the Display Update Rate

- **Time/div**

Select the time corresponding to 1 division of the time axis during trend display from the following.

1 min, 2 min, 5 min, 10 min, 20 min, 30 min, 1 h, 2 h, 4 h, and 10 h

8.9 Measurement Function > Settings Related to Messages Displayed on the Trend Display and Write Operation

This section explains how to set and write the messages that can be displayed on the trend display.

Procedure

Opening the Setting Display

Press the keys in the following sequence:

MENU key (switch to setting mode(control)) > **MENU key** (switch to Set mode) > **#3 soft key** (select [Trend/Save interval,Message,File,User key,DST])

The following display appears.

Setup Procedure

1. Use the **arrow keys** to move the cursor (blue) to one of the [Characters] boxes under [Message].
A soft key menu is displayed at the bottom of the display.
2. Press the **[Input] soft key**.
A message pop-up window appears.
3. Enter the message using the **character/number input key**.
4. Press the **DISP/ENTER key**.
The message pop-up window closes, and the cursor moves to the next [Characters] box.
5. Repeat steps 1 to 4 to enter all the messages you wish.
6. Press the **DISP/ENTER key** to confirm the changes.
The boxes for the items you changed turn from yellow to white, and the cursor returns to the first item box.

Displaying and Writing messages

1. Press the **FUNC key** to display the soft key menu.
2. Press the **[Message] soft key** to display a list of messages.
A soft key menu used to select the message appears.

3. Press the **soft key** corresponding to the message you wish to write.
A message mark, time, and the message itself are displayed on the trend display, and the information is written to the internal memory.

Note

Step 3 above cannot be carried out if acquisition to the internal memory is stopped.

For Models with the Batch header (/BT1 Option)

1. Press the **FUNC key** to display the soft key menu.
2. Press the **[Message] soft key** to display a list of messages.
[Write] and **[Set] soft keys** appear.

Displaying a message on the trend screen/Writing a message to the internal memory

3. Press the **[Write] soft key**. Eight soft keys for the messages and a window containing a list of messages are displayed.
4. Press the **soft key** corresponding to the message you wish to write.
A message mark, time, and the message itself are displayed on the trend display, and the information is written to the internal memory.

Changing message strings

5. Press the **[Set] soft key**. The [Message1] to [Message3] soft keys and a window containing a list of messages are displayed.
6. Press the **soft key** corresponding to the message to be changed. A window to enter a message string appears.
7. Enter the message using the **character/number input key**.
8. Press the **DISP/ENTER key**.

Setup Items

Setting the Messages

- **Characters**

Enter the message string using up to 16 alphanumeric characters. Up to 8 messages can be entered (No. 1 to 8).

8.10 Measurement Function > Changing the Trip Line of the Trend Display

This section explains how to set the trip line that can be displayed on the trend display.

Procedure

Opening the Setting Display

Press the keys in the following sequence:

MENU key (switch to setting mode(control)) > **MENU key** (switch to Set mode) > **#4 soft key** (select [Display]) > **#1 soft key** (select [Group set,Trip line])

The following display appears.

No.	On/Off	Position	Color
1	On	80 %	Red
2	On	20 %	Green
3	Off		
4	Off		

Setup Procedure

1. With the cursor (blue) located at the [Group number] box, select the group number for setting the trip line using the **soft keys**.
The cursor moves to the [Group name] box.
2. Use the **arrow keys** to move the cursor (blue) to the On/Off box under [Trip line].
3. Press the **[On] or [Off] soft key**.
The box for the item you changed turns yellow, and the cursor moves to the next item.
4. If you select [On], set [Position] and [Color] using **soft keys** and **character/number input keys**.
5. Repeat steps 3 to 4 to enter all the trip lines you wish.
6. Press the **DISP/ENTER key** to confirm the changes.
The boxes for the items you changed turn from yellow to white, and the cursor returns to the first item.

Setup Items

Setting the Trip Lines

- **Group number**
Select the group you wish to set a trip line to from [1] to [10]. For the procedure in setting the groups, see *section 8.3, "Measurement Function > Measurement Group Setup Operation."*
- **Trip line**
 - **Off/On**
Turn On the trip line you wish to enable.
 - **Position**
Enter the position in the range of "0 to 100"% of the scale.

- **Color**

The initial color settings of colors are as follows:

Trip line no. 1: red, trip line no. 2: green, trip line no. 3: blue, Trip line no. 4: yellow

To change the color select from the following 16 colors.

Red, green, blue, blue violet, brown, orange, yellow-green, light blue, violet, gray, lime, cyan, dark blue, yellow, light gray, and purple.

8.11 Measurement Function > Changing the Channel Display Color

This section explains how to change the waveform color on trend displays and the bar color on bar graph displays. For the procedures in changing the background color of operation displays such as the control group display, tuning display, and measurement trend display, see *section 8.15, "Measurement Function > Setting the Display Direction, Background Color, Waveform Line Width, Trip Line Width, Grid, and Scroll Time."* For the procedure in changing the trip line color of the measurement trend display, see *section 8.10, "Measurement Function > Changing the Trip Line Of the Trend Displays."* The measurement channel display color cannot be selected on 0 measurement channel models. An error message will appear if the display color setting screen is selected.

Procedure

Opening the Setting Display

- **Colors When Assigning Channels of PV, SP, and OUT**

Press the keys in the following sequence:

MENU key (switch to setting mode(control)) > **MENU key** (switch to Set mode) > **#4 soft key** (select [Display]) > **#5 soft key** (select [Control(Color)])

The following display appears.

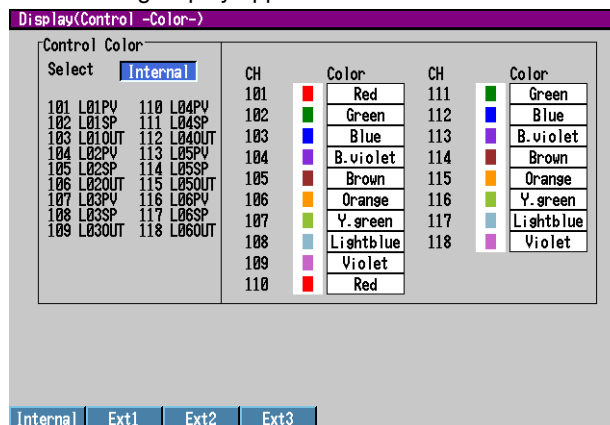

- **Colors of measurement channels**

Press the keys in the following sequence:

MENU key (switch to setting mode(control)) > **MENU key** (switch to Set mode) > **#4 soft key** (select [Display]) > **#2 soft key** (select [Color])

From the operation display, use the above keys to open the following display (for 10CH).

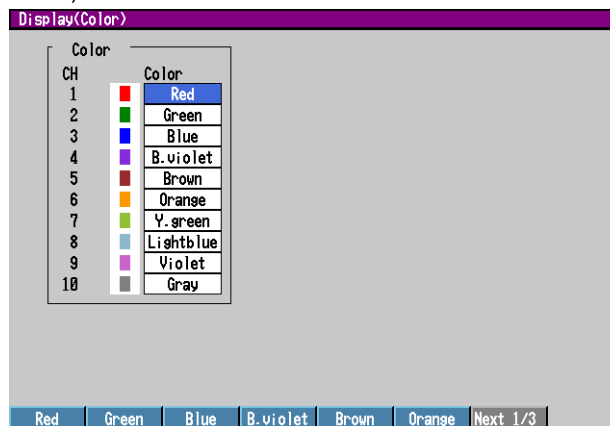

- **Colors of computation channels**

Press the keys in the following sequence:

MENU key (switch to setting mode(control)) > **MENU key** (switch to thetmode) > **#4 soft key** (select [Display]) > **#7 soft key** (select [Math(Color)])

The following display appears.

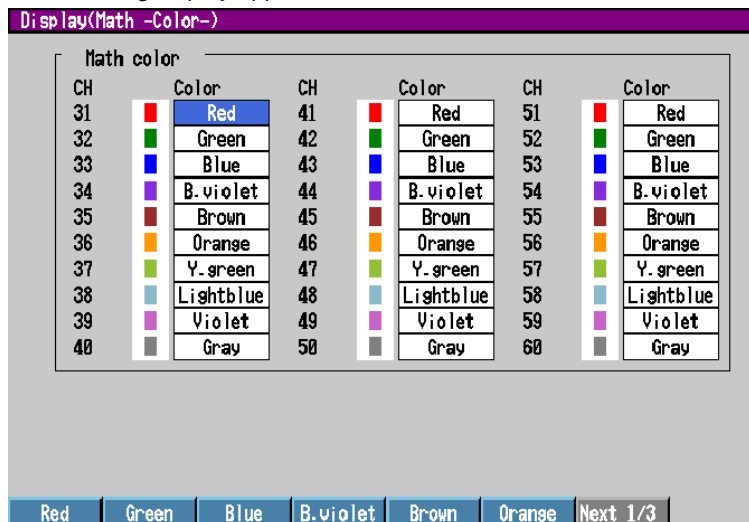

Setup Procedure

1. Use the **arrow keys** to move the cursor (blue) to the [Color] box of the channel you wish to change.
A soft key menu used to select the color appears at the bottom of the display.
On the [Control(Color)] display, you must select the control loop using the [Select] box before this step.
2. Press the **soft key** corresponding to the color you wish to select.
The box for the item you changed turns yellow, and the cursor moves to the next item.
3. Repeat steps 1 and 2 to set all the colors you wish.
4. Press the **DISP/ENTER key** to confirm the changes.
The boxes for the items you changed turn from yellow to white, and the cursor returns to the first item.

Setup Items

Setting the Channel Color

- **Select** (Only when assigning channels of PV, SP, and OUT of control)
Select the group of the control loop you wish to set the color from [Internal], [Ext1], [Ext2], and [Ext3]. The channel assignment of each group is displayed under the [Select] box. For example, [201 L01PV] indicates that the channel number is [201] and the external loop number is [01].
- **Color**
The colors are initially set in the following order for every 9 channels. However, if the number of measurement channels is 10, channel 10 is gray.
1: Red, 2: Green, 3: Blue, 4: Blue violet, 5: Brown, 6: Orange, 7: Yellow green, 8: Light blue, and 9: Violet.
To change the color select from the following 16 colors.
Red, green, blue, blue violet, brown, orange, yellow-green, light blue, violet, gray, lime, cyan, dark blue, yellow, light gray, and purple.

8.12 Measurement Function > Changing the Zone Display of the Trend Display

This section explains how to specify the waveform display zone of each channel. The measurement channel zone cannot be selected on 0 measurement channel models. An error message will appear if the zone or graph setting screen is selected.

Procedure

Opening the Setting Display

Press the keys in the following sequence:

MENU key (switch to setting mode(control)) > **MENU key** (switch to Set mode) > **#4 soft key** (select [Display]) > **#3 soft key** (select [Zone,Graph]), **#6 soft key** (select [Control (Zone,Graph)]), or **#8 soft key** (select [Math (Zone, Graph)])

The following display (if [Zone, Graph] was selected) appears.

If [Aux, Time Zone] > [Partial] is set to [Use], [Zone, Graph] in the menu appears as [Zone, Graph, Partial], and the setting display shows the [Partial] entry box.

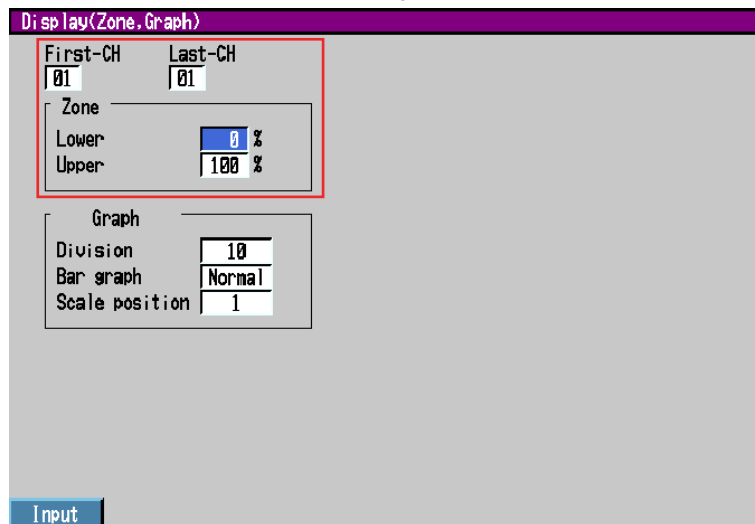

Setup Procedure

1. Use the **arrow keys** to move the cursor (blue) to the item box you wish to change. The selections are displayed at the bottom section of the display.
2. Press the **soft key** corresponding to the value you wish to select. The box for the item you changed turns yellow, and the cursor moves to the next item.
3. Repeat steps 1 and 2 to change the value of all the items you wish to change.

Note

The [Zone Lower/Upper] is set using the pop-up window that appears by pressing the [Input] soft key.

4. Press the **DISP/ENTER key** to confirm the changes. The boxes for the items you changed turn from yellow to white, and the cursor returns to the first item box.

Setup Items

Setting Zone Lower/Upper

- **First-CH/Last-CH**

Set the target channel (common with the [Graph] setting).

Measurement channels: 01 to 20, computation channels: 31 to 60, internal control channels: 101 to 118, external control channels 201 to 248

- **Zone Lower/Upper**

Set the zone for displaying the target channel. You can set [Zone Lower] and [Zone Upper] as a position (%) when taking the maximum display width to be 0 to 100% in the following range.

Zone Lower: 0 to 95%, Zone Upper: 5 to 100%

where “Zone Lower < Zone Upper” and “Zone Upper – Zone Lower ≥ 5%”

8.13 Measurement Function > Setting the Scale Division, Bar Graph Base Position, Scale Position of Trend Displays

This section explains how to set the scale division on trend/bar graph displays, bar graph base position, and the scale display position of each channel on trend displays. The scale division, bar graph base position, and scale position of trend displays cannot be selected on 0 measurement channel models. An error message will appear if the zone or graph setting screen is selected.

Procedure

Opening the Setting Display

- **Setting the scale division, bar graph base position, scale position of trend displays**

Press the keys in the following sequence:

MENU key (switch to setting mode(control)) > **MENU key** (switch to Set mode) > **#4 soft key** (select [Display]) > **#3 soft key** (select [Zone,Graph])

The following display appears.

- **Setting the number of digits displayed for the scale**

Press the keys in the following sequence:

MENU key (switch to setting mode(control)) > **MENU key** (switch to Set mode) > **#4 soft key** (select [Display]) > **#4 soft key** (select [View,Direction,LCD])

The following display appears.

Setup Procedure

1. Use the **arrow keys** to move the cursor (blue) to the item box you wish to change. The selections are displayed at the bottom section of the display.
2. Press the **soft key** corresponding to the value you wish to select. The box for the item you changed turns yellow, and the cursor moves to the next item.
3. Repeat steps 1 and 2 to change the value of all the items you wish to change.
4. Press the **DISP/ENTER key** to confirm the changes. The boxes for the items you changed turn from yellow to white, and the cursor returns to the first item box.

Setup Items

Setting the Scale Division, Bar Graph Base Position, and Scale Position of Trend Displays

- **First-CH/Last-CH**

Set the target channel (common with the [Zone] setting).

- **Graph**

- **Division**

Set the number of main scale marks on the trend display and the number of scale marks on the bar graph from [4] to [12]. In addition to the values of [4] to [12], [C10] is available. When [C10] is selected, the scale is equally divided into 10 sections by main scale marks, and scale values are indicated at 0, 30, 50, 70, and 100% positions on the trend display.

Note

If the number of divisions is set from [8] to [12], scale values are displayed every other main scale mark. In addition, the upper and lower limits of the scale are always displayed at the ends of the scale.

- **Bar graph**

Set the base position of the bar graph when set to horizontal display to [Normal] or [Center]. When the bar graph is displayed vertically, the base position is fixed to [Normal] (the bottom of the bar graph is the base position).

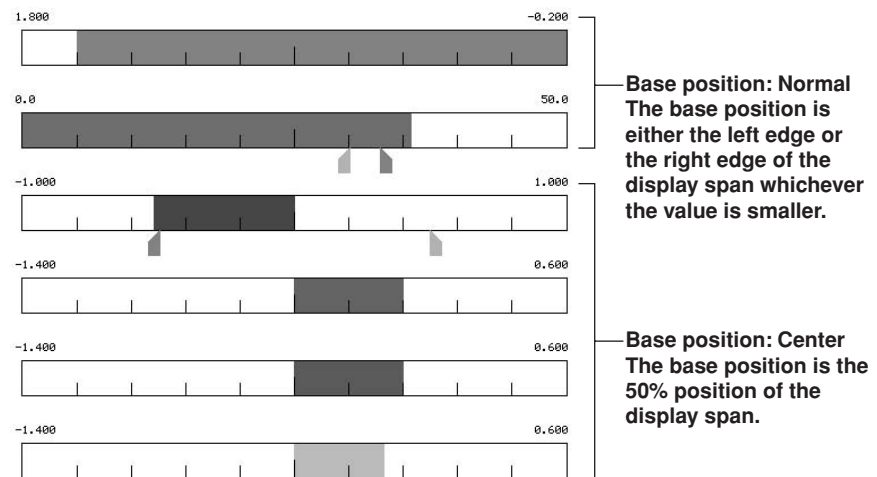

- **Scale position**

Select the scale display position on the trend display from [1] to [10]. When the trend waveform is displayed horizontally, the right end is [1] and the left end is [10]. When the trend waveform is displayed vertically, the top is [1] and the bottom is [10]. Select [Off] if you do not wish to display the scale.

8.13 Measurement Function > Setting the Scale Division, Bar Graph Base Position, Scale Position of Trend Displays

Below is an example in which the position of the scale is offset for each channel.

- When displaying the trend waveform horizontally

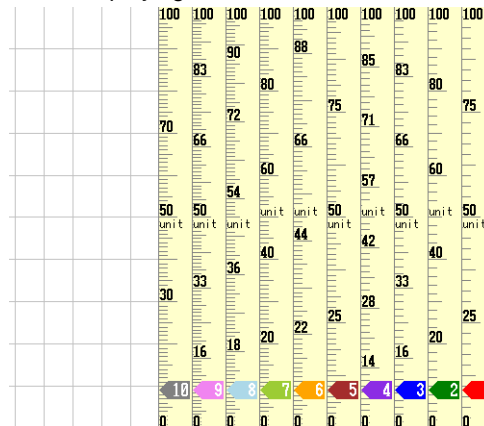

- When displaying the trend waveform vertically

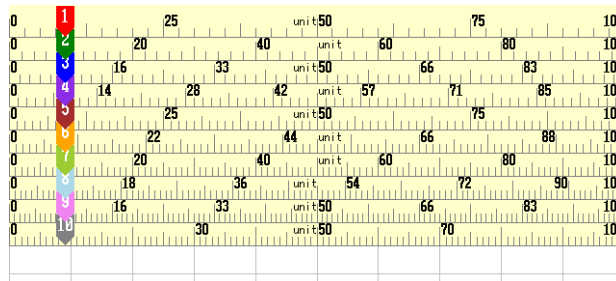

Note

- If the scales of multiple channels are set to the same position, the scale of the channel assigned earlier to the group is displayed.

Example: If the order of assignment of a group is [03.02.01], and the scale display position of all channels is set to [1], the scale of channel 3 is displayed at display position 1.
- Even if some of the scale display positions are skipped, the scale is packed towards display position [1].

Example: Suppose the assignment of channels to a group is [01.02.03], and the display positions of the scales are set to 1, 3, and 6, respectively. The scales are actually displayed at positions 1, 2, and 3, respectively.
- The scale values are displayed according to the following rules.
 - If the number of scale divisions is 4 to 7, values are displayed by all the main scale marks. If the number is 8 to 12, values are displayed by every other main scale marks.
 - Scale upper and lower limits are displayed at the ends of the scale.
 - Scale values are displayed up to 3 digits excluding the minus sign. However, if the integer part of values at the ends of the scale are both 1 digit or the integer part for both is 0, 2 digits are displayed.

Example: If the scale is -0.05 to 0.50 , the lower limit is -0.0 and the upper limit is 0.5 .
 - If the integer part of either end of the scale is 2 or 3 digits, the fractional part is truncated.

Example: If the scale is 0.1 to 100.0 , the lower limit is 0 and the upper limit is 100 .
 - If the integer part of either end of the scale is 4 or more digits, the value is displayed using a 3-digit mantissa and exponent like $\times 10$ or $\times 10^2$.

Example: If the scale is 10 to 2000 , the lower limit is 1 and the upper limit is 200×10 .
- The unit is displayed near the center of the scale. If partial expanded display is used, the display position is offset from the center. When the trend is displayed horizontally, the number of characters that can be displayed is 4 characters or less (6 characters for vertical display).

Setting the Number of Digits Displayed for the Scale

- **Scale digit**

You can select [Normal] or [Fine]. If you select [Fine], the scale value can be displayed using 3 digits when the scale value display is 2 digits. For example, if the scale range is “49.0 to 51.0,” the scale values are displayed using 3 digits as shown below.

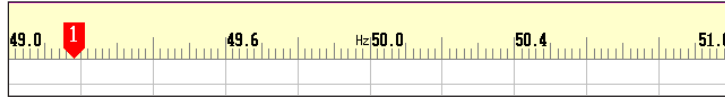

8.14 Measurement Function > Setting the Partial Expanded Display on the Trend Display

This section explains how to display the waveform using the partial expanded display function on the trend display.

Procedure

Opening the Setting Display

- **Enabling/disabling the partial expanded display function**

Press the keys in the following sequence:

MENU key (switch to setting mode(control)) > **Hold down the FUNC key for 3 seconds** (switch to basic setting mode) > **#9 soft key** (select [Aux,Time zone])

The following display appears.

AUX. Time zone	
AUX	
Tag/Channel	Tag
Memory alarm	1h
Language	English
Partial	Use
Time zone	
Difference from GMT	0
Use	Not

- **Detailed setting of the partial expanded display**

The measurement channel partial expanded display cannot be selected on 0 measurement channel models. An error message will appear if the zone, graph, or partial expanded setting screen is selected.

Press the keys in the following sequence:

MENU key (switch to setting mode(control)) > **MENU key** (switch to Set mode) > **#4 soft key** (select [Display]) > **#3 soft key** (select [Zone,Graph,Partial]), **#6 soft key** (select [Control (Zone, Graph, Partial)]), or **#8 soft key** (select [Math (Zone, Graph, Partial)])

The following display appears.

Display(Zone, Graph, Partial)	
First-CH	Last-CH
01	01
Zone	
Lower	0 %
Upper	100 %
Graph	
Division	4
Bar graph	Normal
Scale position	2
Partial	
On/Off	On
Expand	50 %
Boundary	0.01
On	Off

Setup Procedure

1. Use the **arrow keys** to move the cursor (blue) to the item box you wish to change.
A soft key menu is displayed at the bottom of the display.
2. Press the **soft key** corresponding to the value you wish to select.
The box for the item you changed turns yellow, and the cursor moves to the next item.
3. Repeat steps 1 and 2 to change the value of all the items you wish to change.

Note

[Expand] and [Boundary] under [Partial] are set using the pop-up window that appears by pressing the [Input] soft key.

4. Press the **DISP/ENTER key** to confirm the changes.
The boxes for the items you changed turn from yellow to white, and the cursor returns to the first item box.

Saving the Settings in Basic Setting Mode

1. Press the **ESC key**.
The display returns to basic setting menu.
2. Press the **[End] soft key**.
A confirmation dialog box appears
3. Select [Yes] and press the **DISP/ENTER key**.
The operation screen is displayed.

Setup Items

Enabling/Disabling the Partial Expanded Display Function

- **Partial**

To use the partial expanded display function, select [Use] (initial setting is [Not]).

Note

The partial expanded display settings of all channels are set to Off, when the [Partial Use/Not] setting is changed in basic setting mode.

Detailed Setting of the Partial Expanded Display

- **First-CH/Last-CH**

Set the target channel (common with the [Zone] and [Graph] settings).
Measurement channels: 01 to 20, computation channels: 31 to 60, internal control channels: 101 to 118, external control channels 201 to 248

- **Off/On**

To use partial expanded display, select [On] (initial value is [Off]). If [On] is selected, the [Expand] and [Boundary] entry boxes appear.

- **Expand**

Set the position where the boundary value is to be displayed within the display span in the range of [1] to [99]%.

- **Boundary**

Set the value that is to be the boundary between the reduced section and the expanded section in the range of "minimum span value + 1 digit to maximum span value - 1 digit."
However, for channels that are set to scaling or square root computation, the selectable range is "minimum scale value + 1 digit to maximum scale value - 1 digit."

Example

Suppose Expand and Boundary are set to 30 and 0, respectively. The "0% to 30%" below the boundary correspond to "-6 V to 0 V" and "70% to 100%" above the boundary correspond to "0 V to 6 V."

Note

If the range setting of a channel is set to [Skip] or if the span width is less than 1 digit, partial expanded display cannot be used (the [Partial] box is grayed).

8.15 Measurement Function > Setting the Display Direction, Background Color, Waveform Line Width, Trip Line Width, Grid, and Scroll Time

This section explains how to set the display direction of the trends/bar graphs, the background color, the waveform line width, the trip line width, the number of grids, and the automatic switching interval of the displayed groups.

Procedure

Opening the Setting Display

Press the keys in the following sequence:

MENU key (switch to setting mode(control)) > **MENU key** (switch to Set mode) > **#4**

soft key (select [Display]) > **#4 soft key** (select [View,Direction,LCD])

The following display appears.

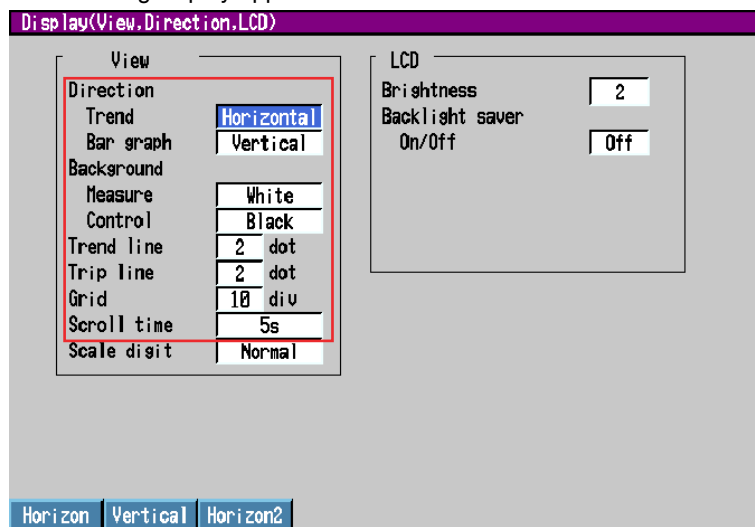

Setup Procedure

1. Use the **arrow keys** to move the cursor (blue) to the item box you wish to change.
A soft key menu is displayed at the bottom of the display.
2. Press the **soft key** corresponding to the value you wish to select.
The box for the item you changed turns yellow, and the cursor moves to the next item.
3. Repeat steps 1 and 2 to change the value of all the items you wish to change.
4. Press the **DISP/ENTER key** to confirm the changes.
The boxes for the items you changed turn from yellow to white, and the cursor returns to the first item box.

Setup Items

Setting the Display Direction, Background Color, Waveform Line Width, Trip Line Width, Grid, and Scroll Time

- **Direction**
 - **Trend**

Select the display direction of the trends from [Horizontal], [Vertical], and [Horizon2]. If [Horizon2] is selected, the trends and scale are arranged vertically and the numerical display section arranged horizontally.

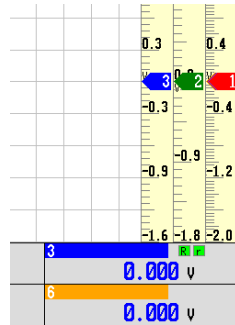

- **Direction**
 - **Bar graph**
- **Background**

Select the display direction of bar graphs from [Horizontal] or [Vertical].

- **Measure**

Select the background color for measurement displays such as the trend display, digital display, bar graph display, and information display from [White] (initial value) and [Black].

- **Control**

Select the background color for control displays such as control group display, tuning display, overview display, DI/DO status display, and program display from [White] and [Black] (initial value).

Note

The background color of the historical trend is set opposite to that of the trend display.

- **Trend line**

Select the line width of the trends from [1], [2], and [3] dots.

- **Trip line**

Select the line width of trip lines from [1], [2], and [3] dots.

- **Grid**

Select the number of grids to be displayed in the waveform display area of the trend display. Select from [Auto], [4] to [12]. If [4] to [12] is selected, the grid is displayed so that the display width is divided into 4 to 12 sections. If [Auto] is selected, the same number of grids as the number of scale divisions of the first assigned channel of the group is displayed.

- **Scroll time**

Select the interval used when automatically switching the trend, digital, and bar graph displays from [5s], [10s], [20s], [30s], and [1min]. The displayed group rotates among group 1 to group 6.

9.1 Acquiring Measurement Data to the Internal Memory and Saving Data to the External Storage Medium

This section explains how to set the acquisition of measurement data (display data, event data, manual sample data, TLOG data (only on models with the computation function option (M1), and report data (only on models with the computation function option (M1)), as well as how to set the storage of data to the external storage medium; and how to start/stop these operations.

Procedure

Opening the Setting Display

- **Setting items other than the auto save interval**

Press the keys in the following sequence:

MENU key (switch to setting mode(control)) > **Hold down the FUNC key for 3 seconds** (switch to basic setting mode) > **#2 soft key** (select [Memory,Memory and trend,Memory timeup])

The following display appears.

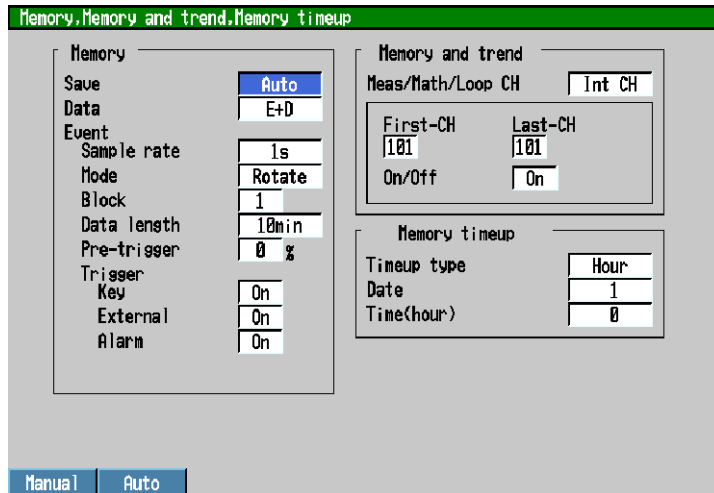

- **Setting the auto save interval, file header/directory name, and the data to be saved during manual save operation.**

Press the keys in the following sequence:

MENU key (switch to setting mode(control)) > **MENU key** (switch to Set mode) > **#3 soft key** (select [Trend/Save interval,Message,File,User key,DST])

- When set to [Auto]

The following display appears.



- When set to [Manual]

The following display appears.

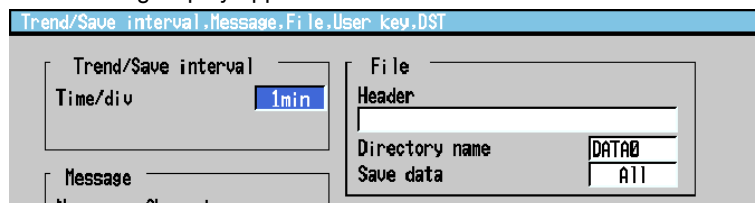

9.1 Acquiring Measurement Data to the Internal Memory and Saving Data to the External Storage Medium

Setup Procedure

1. Use the **arrow keys** to move the cursor (blue) to the item box you wish to change.
A soft key menu is displayed at the bottom of the display.
2. Press the **soft key** corresponding to the value you wish to select.
The box for the item you changed turns yellow, and the cursor moves to the next item.
3. Repeat steps 1 and 2 to change the value of all the items you wish to change.

Note

[Header] and [Directory name] are set using the pop-up window that appears by pressing the [Input] soft key.

4. Press the **DISP/ENTER key** to confirm the changes.
The boxes for the items you changed turn from yellow to white, and the cursor returns to the first item box.

Saving the Settings in Basic Setting Mode

1. Press the **ESC key**.
The display returns to basic setting menu.
2. Press the **[End] soft key**.
A confirmation dialog box appears
3. Select [Yes] and press the **DISP/ENTER key**.
The operation screen is displayed.

Starting the Acquisition to the Internal Memory

Press the **START key**.

When data acquisition to the internal memory starts, the memory operation indicator icon changes from stop indication to run indication as shown below.

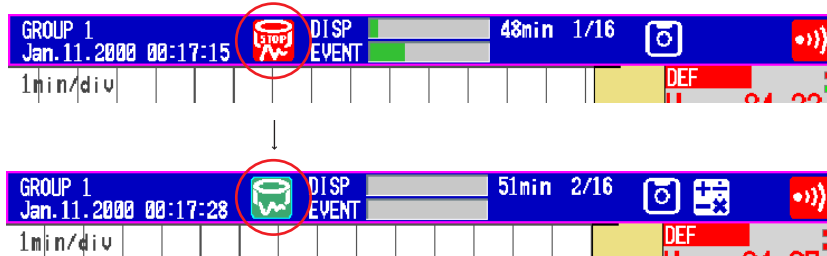

Stopping the Acquisition to the Internal Memory

1. Press the **STOP key**.
2. Use the **left and right arrow keys** to select [Memory] or [Mem+Math] in the confirmation window that appears.

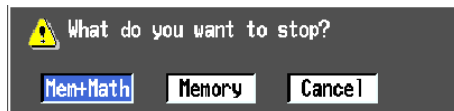

Select [Mem+Math] if you wish to not only stop the acquisition to the internal memory, but also the computation assigned to computation channels.
If the model does not have the optional computation function (/M1), a confirmation message "Do you want to stop storage?" appears. Select [Yes].
If the batch header option is active, the batch information is also displayed.

3. Press the **DISP/ENTER key**.
When data acquisition to the internal memory stops, the memory operation indicator icon changes from run indication to stop indication.

Saving Data Using the Soft Key Menu That Appears by Pressing the [FUNC] Key

If you press the [FUNC] key when [Save] under [Memory] is set to [Auto] and the acquisition of the display data to the internal memory is started, [Save Display] appears in the soft key menu. If you press the [FUNC] key when the acquisition of event data to the internal memory is started in the free mode, [Save Event] appears in the soft key menu. Press these soft keys at any time to store the display data or event data to the external storage medium. For the operation of the [FUNC] key, see *page 3-6*.

Collectively Saving Data When Data Acquisition to the Internal Memory Is Stopped

MENU key (switch to setting mode(control)) > **MENU key** (switch to Set mode) **#5 soft key** (select [Save/Load,Clear data]) > **#3 soft key** (select [Save data])

Note

- If the memory is full or the number of files exceeds 16, the newest data overwrites the oldest data file.
- If a power failure occurs, the file is closed. After the power recovers, a new file is created and data is written there.
- The start/stop operation of the acquisition to the internal memory also starts/stops the report function (on models with the computation function option /M1).
- If the computation is stopped, you can start the computation by starting the acquisition to the internal memory.
- When you stop the acquisition to the internal memory, data is saved to the external storage medium. If the external storage medium is not inserted at this point, an error message "Media has not been inserted" appears.
- You cannot perform the operation of "collectively saving data when data acquisition to the internal memory is stopped" if computation is in progress.
- The procedure for saving all data collectively can only be performed when data acquisition to internal memory is stopped.

Setup Items

Setting the Memory (Acquisition to the Internal Memory and Storage to the External Storage Medium)

• Save

Select the mode used to save the data in the internal memory to the external storage medium from [Auto] and [Manual].

• Manual

When you insert an external storage medium into the drive and close the operation cover, a message "Do you want to save measured data?" appears. Select [Yes] and press the **[DISP/ENTER] key** to save the data.

In manual save mode, set how the data is to be saved, [Unsave] (save only the data that has not been saved) or [All] (save all the data) at [Trend/Save interval,Message,File,User key,DST] setting display > [Save data] (see *page 9-6*).

• Auto

By having the external storage medium inserted in the drive at all times, data save operation is automatically carried out at specified intervals.

• Data

Select the type of data to be acquired to the internal memory from [Display] (display data only), [E+D] (display data and event data), and [Event] (event data only).

• Event (only when [Data] is set to [E+D] or [Event])

• Sample rate

Select the interval used to save the event data from the following.

1s, 2s, 5s, 10s, 30s, 60s, 120s, 300s, and 600s

• Mode

Select the mode from [Free], [Trigger], and [Rotate]. [Free] appears as a choice only when [Data] is set to [Event]. When set to [Free], the following parameters [Block], [Data length], [Pre-trigger], and [Trigger] are not available.

9.1 Acquiring Measurement Data to the Internal Memory and Saving Data to the External Storage Medium

- **Block**

Select the number of blocks when dividing the event data acquisition area into blocks. Select from [2], [4], [8], and [16]. Select [1] if you do not wish to divide the area into blocks. When acquiring both display data and event data, the possible selections are [1], [2], and [4].

- **Data length**

Set the size (data length) of a single block of the event data acquisition area in terms of the amount of time data is to be acquired. The selectable data length varies depending on the sampling interval (sample rate setting) as shown in the table below. It also depends on the block setting and the number of measurement/computation channels.

Sampling interval (s)	1	2	5	10	30	60	120	300	600
Data length (choices)	3min	3min							
	5min	5min							
	10min	10min	10min	10min					
	20min	20min	20min	20min					
	30min	30min	30min	30min					
	1h	1h	1h	1h	1h	1h	1h	1h	1h
	2h	2h	2h	2h	2h	2h	2h	2h	2h
	3h	3h	3h	3h	3h	3h	3h	3h	3h
	4h	4h	4h	4h	4h	4h	4h	4h	4h
	6h	6h	6h	6h	6h	6h	6h	6h	6h
	8h	8h	8h	8h	8h	8h	8h	8h	8h
	12h	12h	12h	12h	12h	12h	12h	12h	12h
	1day	1day	1day	1day	1day	1day	1day	1day	1day
		2days	2days	2days	2days	2days	2days	2days	2days
			3days	3days	3days	3days	3days	3days	3days
			5days	5days	5days	5days	5days	5days	5days
				7days	7days	7days	7days	7days	7days
				10days	10days	10days	10days	10days	10days
					14days	14days	14days	14days	14days
						31days	31days	31days	31days

- **Pre-trigger**

Select the range when saving the data existing before the trigger condition is met as event data. Select the range as a percentage of the data length from [5], [25], [50], [75], [95], and [100]%. If you do not wish to acquire the data existing before the trigger condition is met, select [0]%.

- **Trigger**

Set the trigger condition used to acquire the event data.

- **Key**

Select [On] if you wish to activate the trigger using key operation.

- **External**

Select [On] if you are applying the trigger signal through remote input.

- **Alarm**

Select [On] if you wish to use alarm occurrences as triggers.

Setting Memory and Trend (Setting the Channels for Saving Data)

- **Meas/Math/Loop CH**

Select the type of target channels from [Meas CH], [Math CH], [Int CH] (PV input of internal control loops), [Ext CH] (PV input of external control loops),

- **First-CH/Last-CH**

Set the range of channels to turn [On/Off] depending on the type of target channels.

Meas CH: 01 to 20 ([01] to [10] on models with 10 measurement channels)

Math CH: 31 to 60 (selectable only on models with the computation function option (/M1))

Int CH: 101 to 118 (The maximum channel number varies depending on the maximum control loop)

Ext CH: 201 to 248

- **Off/On**

To save the data on the selected channels, select [On]; otherwise, select [Off].

Setting Memory Timeup

When saving the data to the external storage medium in [Auto] mode, set the time for saving the data when specifying the time using date and time.

- **Timeup type**

Select the time when data is to be saved from the following. Select [Off] if you are not using this function.

Hour: Every hour

Day: Every day at the [Time(hour)] on the hour

Week: Every week on the day specified by [Day of the week] at the [Time(hour)] on the hour

Month: Every month on the day specified by [Date] at the [Time(hour)] on the hour

- **Date/Day of the week**

[Date] is a setting used when [Timeup type] is set to [Month]. Set the value in the range of [1] to [28] (29 to 31 cannot be specified). [Date] also appears when [Timeup type] is set to [Hour] or [Day]. However, the setting is valid only when [Timeup type] is set to [Month].

[Day of the week] is a setting used when [Timeup type] is set to [Week]. Enter the day of the week using the soft key.

- **Time (hour)**

Set the hour when the data is to be saved when [Timeup type] is set to [Day], [Week], or [Month]. This setting is invalid when [Timeup type] is set to [Hour]. Set the hour in the range of [00] to [23].

Setting the Auto Save Interval

- **Auto save interval**

The possible values from the following table is displayed as choices for the auto save interval. The maximum auto save interval varies depending on the display update rate (sampling interval is determined from the display update rate), the data type (display data only/display data and event data), and the number of measurement and computation channels to be stored.

Display Update Rate (/DIV)	1min	2min	5min	10min	20min	30min	1h	2h	4h	10h
Sampling interval (s)	2	4	10	20	40	60	120	240	480	1200
Auto save interval	10min	10min	10min	10min						
	20min	20min	20min	20min						
	30min	30min	30min	30min						
	1h	1h	1h	1h	1h	1h	1h			
		2h	2h	2h	2h	2h	2h	2h		
			3h	3h	3h	3h	3h	3h		
			4h	4h	4h	4h	4h	4h	4h	
				6h	6h	6h	6h	6h	6h	
				8h	8h	8h	8h	8h	8h	8h
					12h	12h	12h	12h	12h	12h
						1day	1day	1day	1day	1day
							2day	2day	2day	2day
								3day	3day	3day
								5day	5day	5day
									7day	7day
									10day	10day
										14day

Setting the File Header/Directory Name, and the Data to Be Saved during Manual Save Operation.

- **File**

- **Header**

Enter the header comment to be written to the display data/event data using up to 32 alphanumeric characters. The specified header is written to all display data, event data, manual sample data, TLOG data (option), and report data (option) files.

- **Director name**

Set the name of the directory for saving the data on the external storage medium. All the data excluding the setup data (display data, event data, manual sample data, TLOG data, report data (only on models with the computation function option), and screen image data) are saved to the specified directory. The setup data is saved to the root directory. The save destination directory varies depending on how the data is saved.

Auto save: Directory specified here.

Manual save: Directory with a sequence number added to the string specified here.

Save using key operation: Directory with "A+sequence number" added to the character string specified here (the sequence number is incremented every time data is saved. For example, if the specified directory name is "DATA0," the first key operation saves the data to the "DATA0.A00" directory. The second key operation saves the data to the "DATA0.A01" directory.)

- **Save data (only when [Save] is set to [Manual])**

Set how data is to be saved when the external storage medium is inserted into the drive in manual save mode. Select [All], which saves all the data in the internal memory, or [Unsave], which saves only the data that has not been saved. The data that is saved is display data, event data, manual sample data, TLOG data, and report data (only on models with the computation function option).

9.2 Saving Measured/Computed Data at Arbitrary Times (Manual Sample)

This section explains how to save the instantaneous values of all measurement/computation channels (excluding measurement channels set to skip and computation channels set to Off) at arbitrary times.

Procedure

1. On the operation display, press the **FUNC** key.
A soft key menu is displayed at the bottom of the display.
2. Press the **[Manual sample]** soft key.



Note

- When manual sample is executed, the instantaneous values of all channels (excluding measurement channels set to skip and computation channels set to Off) are acquired to the internal memory.
- The first time manual sample is executed, a manual sampled data file is created on the external storage medium. The data is appended to this file for each successive manual sample operation.
- Up to 50 sets of data can be acquired to the internal memory. When 50 is exceeded, the data is overwritten from the oldest data.
- The number of manual sample data points in the internal memory can be confirmed using memory summary (see *section 1.16*).
- For the data format of the manual sampled data, see *appendix 5, "Data Formats of ASCII Files."*
- You can assign the manual sample function to the USER key and save the data simply by pressing a single key. For the procedure in assigning the function to the USER key, see *section 11.1*.

9.3 Saving and Loading Setup Data

This section explains how to save the setup data to the external storage medium and how to change the settings by loading the setup data from the external storage medium. Saving of the setup data is possible only in setting mode.

Procedure

Displaying the Operation Display

- **Saving Setup Data**

Press the keys in the following sequence:

MENU key (switch to setting mode(control)) > **MENU key** (switch to Set mode) **#5 soft key** (select [Save/Load,Clear data]) **#1 soft key** (select [Save settings])

The following display appears.

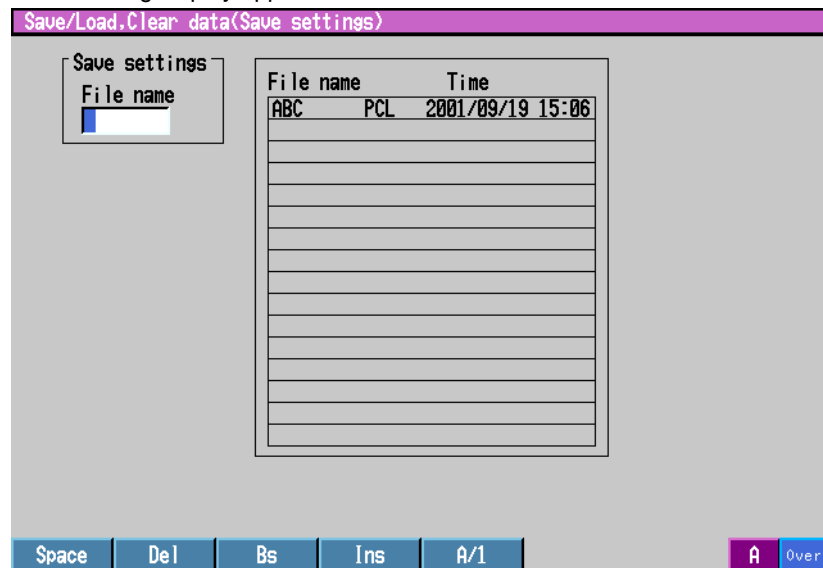

- **Loading Setup Data**

When loading the data in Set mode (loading only the setup data of Set mode)

Press the keys in the following sequence:

MENU key (switch to setting mode(control)) > **MENU key** (switch to Set mode) **#5 soft key** (select [Save/Load,Clear data]) > **#2 soft key** (select [Load settings])

Display Operation in basic setting mode

Press the keys in the following sequence:

MENU key (switch to setting mode(control)) > **Hold down the FUNC key for 3 seconds** (switch to basic setting mode) > **#5 soft key** (select [Load, Initialize]) > **#1 soft key** (select [Load settings])

The following display appears. The following figure shows the display that is shown in Set mode. In basic setting mode, only the display title is different.

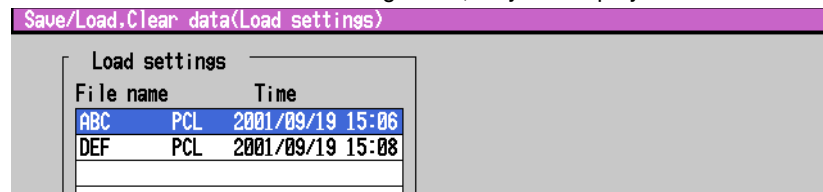

Note

If you attempt to load the setup data and the external storage medium does not contain the setup data, a message "There is no setting file" appears.

Operations on the Display• **Saving Setup Data**

1. Enter the file name in the [File name] box (up to eight characters).
2. Press the **DISP/ENTER key**.

The setup data is saved to the external storage medium. The saved file is displayed in the file list section on the right side.

If the file with the same name exists on the external storage medium, a message confirming file overwrite appears. To overwrite the file, select [Yes] and press the DISP/ENTER key.

• **Loading Setup Data**

1. Select the file to be loaded from the file list of the external storage medium using the **up and down arrow keys**.
2. Press the **DISP/ENTER key**.

The setup data is loaded. When the data is loaded, the settings are changed, and the CX2000 returns to the operation display.

Setup Items**Saving Setup Data**

- All the setup data of both modes (setting mode and basic setting mode) are stored.
- Set the file name using up to 8 characters. The following character strings cannot be used.
AUX, CON, PRN, NUL, CLOCK, and strings containing spaces.
- A .pcl extension is automatically added to the file name of the setup data.
- The size of a setup data file is approximately 200 KB (approximately 70 KB if no program control settings are present) at maximum.

Loading Setup Data

- Loading the setup data in basic setting mode loads all of the setup data of Set mode and basic setting mode. Loading the data in Set mode loads only the setup data of Set mode.
- If the contents of the loaded setup data are invalid, refer to the error message log that appears by pressing the FUNC key and soft keys. For the procedure of displaying the error message log, see *section 11.4, "Displaying Logs (Checking Operations) and System Information Display (Checking the System Specifications)."*
- A .pcl extension is automatically added to the file name of the setup data.

Precautions to Be Taken When Loading Setup Data

As a general rule, load setup data of the same firmware version. If you must load setup data of different versions, note the following points.

• **When loading setup data that has been saved on version 3.01 using version 3.02**

Event output settings (time event, PV event, and program pattern end signal settings) in Setting mode (Control) are not loaded.

• **When loading setup data that has been saved on version 3.02 using version 3.01**

- Event output setting (common or separate) in Basic Control Settings is not loaded.
- Event output settings (time event, PV event, and program pattern end signal settings) in Setting mode (Control) are not loaded.
- Setup data is not loaded when the displayed language is set to Chinese.

9.5 Managing Files and Checking the Free Space on the External Storage Medium

[Display Operation in basic setting mode]

MENU key (switch to setting mode(control)) > **Hold down the FUNC key for 3 seconds** (switch to basic setting mode) > **#5 soft key** (select [Load, Initialize])

After carrying out the steps above, select the one of the following soft keys according to your needs. The display that appears are similar to those shown in Set mode.

- **Deleting files: #3 soft key** (select [Delete])
- **Formatting the external storage medium: #4 soft key** (select [format])

Operations on the Display

- Deleting files or directories
 1. From the directories listed in the [Directory name] box, select the directory in which the file you wish to delete is located using the **up and down arrow keys**.
To delete a directory, select the directory and proceed to step 4.
 2. Press the **right arrow key** to move the blue cursor to the file list section.
 3. Select the file to be deleted using the **up and down arrow keys**.
To move the blue cursor back to the [Directory name] column, press the left arrow key.
 4. Press the **DISP/ENTER key**.
A dialog box for confirming the deletion appears.
 5. Select [Yes] and press the **DISP/ENTER key**.
To cancel the operation, select [No] using the right arrow key and press the DISP/ENTER key.
- Formatting the External Storage Medium
 1. Enter the volume name in the [Volume name] box.
The following character strings cannot be used in the volume name.
AUX, CON, PRN, NUL, CLOCK, and strings containing spaces.
If you are not going to set the volume name, move the cursor to the [Type] box using the down arrow key.
 2. Select [Quick] or [Normal] using the **soft keys**.
 3. Press the **DISP/ENTER key**.
A format confirmation window appears.
 4. Select [Yes] and press the **DISP/ENTER key**.
To cancel the operation, select [No] using the right arrow key and press the DISP/ENTER key.

Note

When using storage media formatted by the instrument on a Windows 2000 PC, you must change the volume label.

Setup Items

Formatting the External Storage Medium

• **Type**

Select from the following.

Quick: Performs only a logical format.

Normal: Performs a physical format and a logical format.

Disk Format

Floppy disk: 2HD, 1.44 MB

Zip disk: FDISK 1 partition (hard disk format)

ATA flash memory card: FDISK 1 partition (hard disk format)

Format Time

External Storage Media Type	Quick	Normal	Notes
Floppy disk	Approx. 6 s	Approx. 1 minute 30 s	
Zip disk	Approx. 3 s	Approx. 10 minutes	
ATA flash memory card	Approx. 3 s	Approx. 1 minute 30 s	24 MB
	Approx. 5 s	Approx. 6 minutes	160 MB

Note

Only 100 MB Zip disks can be used with model CX2***-2. With model CX2***-5, 250 MB and 100 MB Zip disks can be used. However, 100 MB Zip disks must be formatted using quick (logical) formatting rather than normal (physical) formatting.

9.6 Saving the Screen Image Data

This section explains how to save the screen image data to the external storage medium.

Procedure

1. In operation mode, press the **FUNC key**.
A soft key menu is displayed at the bottom of the display.
2. Press the **[Snapshot] soft key**.
The position where the [Snapshot] soft key appears varies depending on the setting. If the [Snapshot] soft key does not appear when you press the [FUNC] key, press the [Next 1/2] soft key to display the next soft key menu page.



Note

This operation can be assigned to the USER key. If it is, screen image data can be saved simply by pressing a single key. When using the steps above, only the screen image of the operation display is possible. However, when using the USER key, screen images of setting displays can also be saved. For the procedure in assigning a function to the USER key, see section 11.1, "USER Key Assignment and Operation."

Setup Items

Saving the Screen Image Data

- **File Format**

The file is in PNG format.

- **File name**

The file name "(month, day, hour, minute when the save operation of the screen image data was executed+sequence number).png" is automatically assigned to the screen image data files.

Mddhhmma.PNG

M: Month (1-9, X (October), Y (November), Z (December)), dd: day, hh: hour, mm: minute, a: the lowest digit of the year (0 to 9, except if the screen image data is saved multiple times within a minute, in which case "a" to "z" are assigned in order from the second file)

9.7 Clearing the Data in the Internal Memory

This section explains how to clear all the data in the internal memory including display data, event data, manual sample data, TLOG data (optional function data), and report data (optional function data).

Procedure

Opening the Operation Dialog Box

Press the keys in the following sequence:

MENU key (switch to setting mode(control)) > **MENU key** (switch to Set mode) **#5 soft key** (select [Save/Load, Clear data]) > **#9 soft key** (select [Clear data])

From the operation display, use the above keys to open the following display box.

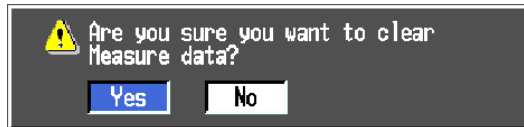

Operations on the Display

Select [Yes] and press the **DISP/ENTER key**.

The data is cleared. To cancel the operation, select [No] using the right arrow key and press the DISP/ENTER key.

Note

The data acquired in the internal memory is also cleared when memory-related settings are changed in basic setting mode. In this case, the following confirmation dialog box appears.



10.1 Assigning Computation Channels and Setting Computing Equations, Constants and Tags

This section explains how to set computing equations to computation channels and how to set tags. You cannot set computing equations while data is being acquired to the internal memory or while computation is in progress.

Equations cannot be used with measurement channels on 0 measurement channel models.

Procedure

Opening the Setting Display

- **Assigning Computation Channels and Setting Equations**

Press the keys in the following sequence:

MENU key (switch to setting mode(control)) > **MENU key** (switch to Set mode) > **#7 soft key** (select [Math set1(Expression,Alarm,Constant)])

The following display appears.

- **Setting Tags of Computation Channels**

Press the keys in the following sequence:

MENU key (switch to setting mode(control)) > **MENU key** (switch to Set mode) > **#8 soft key** (select [Math set2(Tag,TLOG,Rolling average,Alarm delay)])

The following display appears.

Setup Procedure

- **Assigning Computation Channels**

1. Use the **arrow keys** to move the cursor (blue) to the [First-CH] and [Last-CH] boxes.
2. Press the **soft key** corresponding to the start and end channel numbers for setting the computation channels.
3. With the cursor (blue) at the [Math On/Off] box, press the [On] soft key. The [Calculation expression], [Span Lower], [Span Upper], and [Unit] boxes appear.

- **Calculation expression**

1. With the cursor (blue) at the [Calculation expression] box, press the **[Input] soft key**.

The following expression pop-up window appears.

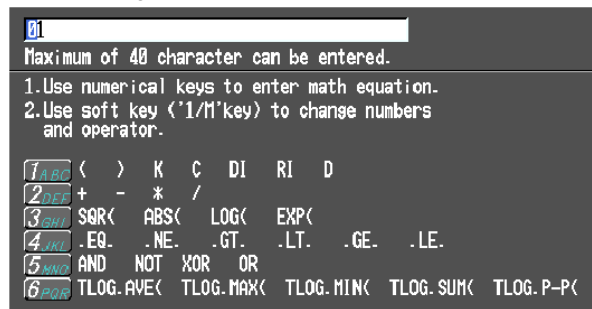

2. Enter the equation using the **soft keys** and **character/number input keys**.
3. Press the **DISP/ENTER key**. The input equation is displayed in the [Calculation expression] box.

- **Span Lower/Upper, Unit**

1. With the cursor (blue) at the [Span Lower], [Span Upper], and [Unit] boxes, press the **[Input] soft key**.
2. Enter the values using the **soft keys** and **character/number input keys**.
3. Press the **DISP/ENTER key**.

- **Constant**

1. Use the **arrow keys** to move the cursor (blue) to the desired constant [K01] to [K30] under [Constant] you wish to change.
2. Enter the constant using the **soft keys** and **character/number input keys**.
3. Press the **DISP/ENTER key**.

- **Tag**

1. Use the **arrow keys** to move the cursor (blue) to the [First-CH] and [Last-CH] boxes.
2. Press the **soft key** corresponding to the start and end channel numbers for setting the tag.
3. Move to the [Tag] box using the **arrow keys**.
4. Enter the tag using the **soft keys** and **character/number input keys**.
5. Press the **DISP/ENTER key**.

Setup Items

Assigning Computation Channels

- **First-CH/Last-CH**

You can assign channel numbers [31] to [60] as computation channels. The range of numbers here is used to set the range of channels for setting the computation function.

- **Math Off/On**

Turn ON/OFF the computation function for the computation channels specified by First-CH and Last-CH.

- **Calculation expression**
Set the equation (up to 40 characters) according to the description given on the equation pop-up window. For a description on how to create equations, see *appendix 3, "Meaning and Syntax of Computing Equations."*
- **Span Lower/Upper**
Set the upper and lower limits of the computation span (range of computed values). Selectable range of values and the decimal place are as follows.
Selectable range of values: -9999999 to 99999999
Selectable decimal places: X.XXXX, XX.XXX, XXX.XX, XXXX.X
- **Unit**
Enter the unit of the computed result using up to 6 alphanumeric characters.
- **Constant**
Set the constants (K01 to K30) that are used in the equations. The number of significant digits is 5 excluding the decimal point. When specifying the constant using exponential notation, the mantissa is less than or equal to 5 digits, and the exponent less than or equal to 2 digits.
The selectable range is as follows.
-9.9999E+29 to -1.0000E-30, 0, 1.0000E-30 to 9.9999E+29

Note

If the Math On/Off, calculation expression, or span setting is changed, the alarms for that channel are turned [Off].

Setting Tags of Computation Channels

- **First-CH/Last-CH**
You can assign channel numbers [31] to [60] as computation channels. The range of numbers here is used to set the range of channels for setting the tag. The target channels also apply to [Alarm delay], [TLOG], and [Rolling average] settings.
- **Tag**
Enter the tag name using up to 16 alphanumeric characters.

Note

For the procedure in displaying tags in place of channel numbers, see *section 8.4, "Measurement Function > Settings Related to Tag Display for Channels."*

10.2 Starting, Stopping, and Resetting the Computation

This section explains how to start/stop computation, how to reset computation, and how to clear the computation data dropout indication.

Procedure

Starting Computation

Press the **START key**.

When the START key is pressed, data acquisition to the internal memory also starts. While computation is in progress, a computation icon is displayed in the operation status display section.



- **Starting Only the Computations**

In operation mode, press the **FUNC key** to display the soft key menu, and press the **[Math START] soft key**. This operation can be assigned to the USER key.

Stopping the Computations

1. Press the **STOP key**.

The following dialog box appears for confirmation.

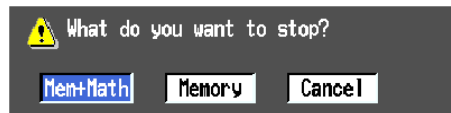

2. Select [Mem+Math] and press the **DISP/ENTER key**.

When the DISP/ENTER key is pressed, data acquisition to the internal memory also stops.

- **Stopping Only the Computations**

In operation mode, press the **FUNC key** to display the soft key menu, and press the **[Math STOP] soft key**. This operation can be assigned to the USER key.

Note

When the computation is stopped, the computed data of the computation channel is held at the value that existed immediately before. If data is being acquired to the internal memory, the value held is written.

Resetting the Computations

1. In operation mode, press the **FUNC key** to display the soft key menu.
2. Press the **[Math reset] soft key**. The data of all computation channels is reset to 0. This operation can be assigned to the USER key.

Clearing the Computation Dropout Indication

In operation mode, press the **FUNC key** to display the soft key menu, and press the **[Math ACK] soft key**.

[Math ACK] appears on the soft key menu only when a computation data dropout occurs (the computation icon turns yellow). When cleared, the computation icon returns to a white color.

Note

Computation data dropout occurs when the computation process cannot be completed within the scan interval. If computation dropout occurs frequently, lessen the load on the CPU by reducing the number of computation channels or setting a longer scan interval. When computation data is written to the internal memory, the data immediately before the computation dropout is substituted as the computation data of the scan interval when dropout occurred.

10.3 Setting Computation Channel Alarms

Like measurement channels, alarms can be output based on the values of the computation channels. This section explains how to set the alarms.

Procedure

Opening the Setting Display

- **Setting the alarm**

Press the keys in the following sequence:

MENU key (switch to setting mode(control)) > **MENU key** (switch to Set mode) > **#7 soft key** (select [Math set1(Expression,Alarm,Constant)])

The following display appears.

Type	Value	Relay On/Off	Number	Detect
On	H	0.00	On	I01
On	L	-70.00	Off	
Off				
Off				

- **Setting the alarm delay**

Press the keys in the following sequence:

MENU key (switch to setting mode(control)) > **MENU key** (switch to Set mode) > **#8 soft key** (select [Math set2(Tag,TLOG,Rolling average,Alarm delay)])

The following display appears.

Setup Procedure

- **Setting the alarm**
 1. Use the **arrow keys** to move the cursor (blue) to the [First-CH] and [Last-CH] boxes.
 2. Press the **soft key** corresponding to the start and end channel numbers for setting the alarm.
 3. Use the **arrow keys** to move the cursor (blue) to the Math alarm [1] to [4] boxes.
 4. Press the **[On] soft key** corresponding to the alarm you wish to select. [Type], [Value], and [Relay On/Off] entry boxes appear.
 5. Use the **arrow keys** to move the each of the entry boxes and select the alarm type, alarm value, and relay output On/Off using the **soft keys**.
If [Relay On/Off] is set to [On], the [Number] box appears.
 6. If [Relay On/Off] is set to [On], select the relay output number from [I01] to [I06], [D0001] to [D0006], [D0101] to [D0106], [D0201] to [D0206], [R001] to [R012], and [SW001] to [SW036] using the **soft keys**.
 7. Press the **DISP/ENTER key**.
- **Setting the alarm delay**
 1. Use the **arrow keys** to move the cursor (blue) to the [First-CH] and [Last-CH] boxes.
 2. Press the **soft key** corresponding to the start and end channel numbers for setting the alarm.
 3. Use the **arrow keys** to move the cursor (blue) to the [Time] box under Alarm delay.
 4. Press the **[Input] soft key** and set the alarm delay time on the pop-up window.
 5. Press the **DISP/ENTER key**.

Setup Items

Math alarm

- **Off/On**

Four alarms (alarm numbers 1 to 4) can be specified for the selected alarm channel. Set the desired alarm to [On].
- **Type**

Select the alarm type from the following four types.

H (High limit alarm):	An alarm occurs when the measured/computed value exceeds the alarm value.
L (Lower limit alarm):	An alarm occurs when the measured/computed value falls below the alarm value.
T (Delay high limit alarm):	An alarm occurs when the computed value remains above or equal to the alarm value for the specified delay.
t (Delay low limit alarm):	An alarm occurs when the computed value remains below or equal to the alarm value for the specified delay.
- **Value**

Set the value according to the [Type] you selected above. The selectable range is the range defined by [Span Upper/Lower] that was specified in “Assigning Computation Channels” (see the *previous section*).
- **Relay On/Off**

Select whether to enable [On] or disable [Off] the relay output.

- **Number**

Set the output relay number when performing relay output.
The selectable output relay numbers are as follows.

- When outputting the signal from the [ALARM] terminal of the measurement alarm output terminal block
I01 to I06
(Displayed even when none of the "/A6, /A6R, /A4F, and /A4FR" options of the measurement alarm output terminal block is specified.)
- When outputting the signal from the [DIGITAL OUT] terminals 1 to 6 of the control output terminal block
DO001 to DO006 (Contact output of loop 1 and 2 control output terminal block)
DO101 to DO106 (Contact output of loop 3 and 4 control output terminal block)
DO201 to DO206 (Contact output of loop 5 and 6 control output terminal block)
(If some of the control output terminal blocks are not installed, the relay numbers for those terminals are not displayed.)
- When outputting the signal from the [DIGITAL OUT] terminals 1 to 12 of the control DIO expansion terminal block
RO001 to RO012
(Only displayed when the control DIO expansion terminal block option "/CST1" is specified.)
- When outputting to the internal switches (SW001-SW36), select from SW001-SW036 (style number S3 or later).

Note

- The terminals that can be set to alarm outputs are referred to as relay outputs in the settings. Actually, two types of terminals can be set to alarm outputs: relay output terminal and transistor output. Only [ALARM] terminals 1 to 6 of the measurement alarm output terminal block and [DIGITAL OUT] terminals 1 and 2 of the control output terminal block are relay outputs.
 - In addition to alarm outputs of measurement/computation channels, the following outputs can also be assigned simultaneously to the [DIGITAL OUT] terminals of the control output terminal block and [DIGITAL OUT] terminals of the control DIO expansion terminal block
 - Control alarm
 - FAIL (only the [DIGITAL OUT] terminal 1 of the control output terminal block)
 - Self diagnosis (only the [DIGITAL OUT] terminal 1 of the control output terminal block)
 - PV event output/time event output (only when the program control option is specified)
 - Program control end notification (only when the program control option is specified)
-

- **Detection (Style Number S3 or Later)**

Select whether to display alarms (ON) or not to display alarms (OFF) when they occur. When turned OFF, they are not retained in the alarm summary.

Setting the Alarm Delay (When [Type] is set to [T] or [t])

- **First-CH/Last-CH**

Select the target channels for setting the alarm delay. The target channels also apply to [Tag], [TLOG], and [Rolling average] settings.

- **Alarm delay**

Set the alarm delay using an integer in the range of [1] to [3600] s.

Note

If the scan interval is 2 s and you set an odd value for the alarm delay period, it will operate at the specified period + 1 s.

Example: If the alarm delay set to 5 s, the function will operate at 6 s.

10.4 Setting TLOG Computations

This section explains how to set the TLOG computation.

Procedure

Displaying the Operation Display

- **Setting the timer**

Press the keys in the following sequence:

MENU key (switch to Set mode) > **Hold down the FUNC key for 3 seconds** (switch to basic setting mode) > **#6 soft key** (select [Option])

The following display appears.

Remote		Report	
No.	Action	Report set	Off
1	None	Report CH	R01
2	None	On/Off	On
3	None	Channel	01
4	None	Sum scale	/s
5	None		
6	None		
7	None		
8	None		

Timer(TLOG)					
No.	Mode	Interval	Ref.time	Reset	Action
1	Absolute	1h	0:00	On	DataSave
2	Relative	01:00		Off	Off
3	Off				

Off Relative Absolute

- **Selecting the Timer and Sum Scale**

Press the keys in the following sequence:

MENU key (switch to setting mode(control)) > **MENU key** (switch to Set mode) > **#8 soft key** (select [Math set2(Tag,TLOG,Rolling average,Alarm delay)])

The following display appears.

First-CH		Last-CH	
31	31		

Tag		Alarm delay	10 s
Tag		Time	

TLOG	
Timer No.	1
Sum scale	/s

Rolling average	
On/Off	On
Interval	10s
Number of samples	1

31 32 33 34 35 36 Next 1/5

Operations on the Display

- **Setting the timer**
 1. Use the **arrow keys** to move the cursor (blue) to the entry boxes under [Timer(TLOG)].
 2. Press the **soft key** to set the values.
 3. Press the **DISP/ENTER key**.
- **Selecting the Timer and Sum Scale**
 1. Use the **arrow keys** to move the cursor (blue) to the [First-CH] and [Last-CH] boxes.
 2. Press the **soft key** corresponding to the start and end channel numbers for setting the TLOG computation.
 3. Use the **arrow keys** to move the cursor to the [Timer No.] or [Sum scale] box under [TLOG].
 4. Select the value using the **soft key**.
 5. Press the **DISP/ENTER key**.

Saving the Settings in Basic Setting Mode

1. Press the **ESC key**.
The display returns to basic setting menu.
2. Press the **[End] soft key**.
A confirmation dialog box appears
3. Select [Yes] and press the **DISP/ENTER key**.
The operation screen is displayed.

Setup Items**Setting Timer for TLOG Computation**• **Mode**

Select either [Relative] or [Absolute].

When Relative Is Selected• **Interval**

Set the time until the end of the interval in “hour:minute” (00:01 to 24:00).

• **Reset**

Set whether to reset the TLOG computation value at every interval [On] or [Off].

• **Action**

If set to [DataSave], the instantaneous values of all measurement/computation channels are written to the internal memory at every interval. Select [Off] to disable this function.

When Absolute Is Selected• **Interval**

Set the time until the end of the interval from the following 19 types.

1min, 2min, 3min, 4min, 5min, 6min, 10min, 12min, 15min, 20min, 30min, 1h, 2h, 3h, 4h, 6h, 8h, 12h, and 24h

• **Ref. time**

Set the time to be used as the reference. The reference time is set in the range of 0:00 to 23:00 at 1 hour steps.

• **Reset**

Set whether to reset the TLOG computation value at every interval [On] or [Off].

• **Action**

If set to [DataSave], the instantaneous values of all measurement/computation channels are written to the internal memory at every interval. Select [Off] to disable this function.

Selecting the Timer Number and Sum Scale of the TLOG Computation

- **First-CH/Last-CH**

You can assign channels numbers 31 to 60 as computation channels. Set a range of channel numbers within this range for setting the timer number and sum scale of the TLOG computation. The target channels also apply to [Tag], [Rolling average], and [Alarm delay] settings.

- **TLOG**

- **Timer No.**

Select the timer number from [1], [2], and [3].

- **Sum scale**

Select the sum scale for calculating the sum (TLOG.SUM) from [Off], [/s], [/min], and [/h]. The initial value is [Off] (simply compute the sum). You only have to set the channels that are set to sum computation (TLOG.SUM).

Note

- When storing the data to the external storage medium, the data is stored to the TLOG data file (.dtg extension).
 - If the timer is specified, the TLOG data is written to the internal memory at the interval specified by the timer. This operation is executed independent of the setting in the [Action] box.
-

10.5 Setting the Rolling Average

This section explains how to set the computed value to the rolling average of the computed results.

Procedure

Opening the Operation Display

Press the keys in the following sequence:

MENU key (switch to setting mode(control)) > **MENU key** (switch to Set mode) > **#8 soft key** (select [Math set2(Tag,TLOG,Rolling average,Alarm delay)])

The following display appears.

The screenshot shows a control panel interface. At the top, it displays 'CONTROL GROUP1', 'Sep. 19. 2001 17:07:18', a 'STOP' button, 'DISP', a '1hour' timer, a download icon, and a red alarm icon. Below this is a green header bar with the text 'Math set2(Tag,TLOG,Rolling average,Alarm delay)'. The main display area is divided into several sections: 'First-CH' and 'Last-CH' both set to '31'; 'Tag' set to '31'; 'Alarm delay' set to '10 s'; 'TLOG' with 'Timer No.' set to '1' and 'Sum scale' set to '/s'; and 'Rolling average' with 'On/Off' set to 'On', 'Interval' set to '10s', and 'Number of samples' set to '1'. At the bottom, there is a navigation bar with buttons for '31', '32', '33', '34', '35', '36', and 'Next 1/5'.

Operations on the Display

1. Use the **arrow keys** to move the cursor (blue) to the [First-CH] and [Last-CH] boxes.
2. Press the **soft key** corresponding to the start and end channel numbers for setting the [Rolling Average].
3. Use the **arrow keys** to move the cursor (blue) to the entry boxes under [Rolling average].
4. Press the **DISP/ENTER key**.

Setup Items

Setting the Rolling Average

- **Off/On**

To take the rolling average of the measured results, select [On] (initial value is [Off]).

- **Interval**

Select the sampling interval when taking the rolling average from the following:

1s, 2s, 3s, 4s, 5s, 6s, 10s, 12s, 15s, 20s, 30s, 1min, 2min, 3min, 4min, 5min, 6min, 10min, 12min, 15min, 20min, 30min, and 1h.

However, if the scan interval is set to [2s], the sampling interval cannot be set to [1s]. In addition, if the scan interval is set to [2s] and the sampling interval is set to an odd-numbered sampling interval [1s], [3s], [5s], or [15s], the actual sampling interval is set to [2s], [4s], [6s], or [16s], respectively.

- **Number of samples**

Set the average count when taking the rolling average using an integer between [1] and [64].

10.5 Setting the Rolling Average

Note

- If the number of data points to be averaged has not reached the specified number of samples immediately after computation is started, the average of the available data is calculated.
 - Computation error data is excluded from the rolling average computation.
 - If the computed data exceeds the upper or lower limit, the data is clipped at the upper or lower limit, and the rolling average is computed. The upper and lower limit is “±100000000” excluding the decimal point. The decimal point position is the same as that of the span lower limit.
-

10.6 Creating Reports

This section explains how to set the report type, report creation channels, report creation time, and other items.

Measurement channels cannot be assigned to report channels on 0 measurement channel models.

Procedure

Opening the Operation Display

Press the keys in the following sequence:

MENU key (switch to Set mode) > **Hold down the FUNC key for 3 seconds** (switch to basic setting mode) > **#6 soft key** (select [Option])

The following display appears.

The screenshot shows the 'Option' menu with three main sections: Remote, Report, and Timer (TLOG). At the bottom, there are six soft key options: Off, Hour, Day, Hour+Day, Day+Week, and Day+Month.

Remote	
No.	Action
1	None
2	None
3	None
4	None
5	None
6	None
7	None
8	None

Report	
Report set	Hour
Date	1
Time(hour)	0
Report CH	R01
On/Off	On
Channel	01
Sum scale	/s

Timer(TLOG)					
No.	Mode	Interval	Ref.time	Reset	Action
1	Absolute	1h	0:00	Off	Off
2	Relative	01:00		Off	Off
3	Off				

Operations on the Display

1. Use the **arrow keys** to move the cursor (blue) to the item box you wish to change. A soft key menu is displayed at the bottom of the display.
2. Press the **soft key** corresponding to the value you wish to select. The box for the item you changed turns yellow, and the cursor moves to the next item.
3. Repeat steps 1 and 2 to change the value of all the items you wish to change.
4. Press the **DISP/ENTER key** to confirm the changes. The boxes for the items you changed turn from yellow to white, and the cursor returns to the first item box.

Saving the Settings in Basic Setting Mode

1. Press the **ESC key**. The display returns to basic setting menu.
2. Press the **[End] soft key**. A confirmation dialog box appears.
3. Select [Yes] and press the **DISP/ENTER key**. The operation screen is displayed.

Setup Items

Setting the Report Function

- Report set
Select the type of report to be created from the following.
Hour: Create hourly reports.
Day: Create daily reports.
Hour+Day: Create hourly and daily reports.
Day+Week: Create daily and weekly reports.
Day+Month: Create daily and monthly reports.
- Date/Day of the week
Set the date or day of the week on which the report is to be created.
If [Report set] is set to [Day+Month], [Date] is displayed. If [Day+Week] is specified, [Day of the week] is displayed. If [Hour], [Day], or [Hour+Day] is specified, [Date] is displayed. However, this setting is void.
- Date (for monthly reports)
Enter the date [01] to [28]. You cannot specify 29, 30, or 31.
- Day of the week (for weekly reports)
Select the day of the week.
- Time(hour)
Set the time when the report is to be created. The reference time is set in the range of 0:00 to 23:00 at 1 hour steps.
- Report CH
Select the report channel [R01] to [R30] to which measurement/computation channels are assigned. The data of measurement/computation channels are output in order according to this number.
- Off/On
Select whether to use the report channel [On] or [Off].
- Channel
Set the measurement or computation channel to assign to the report channel. All measurement and computation channels can be specified. However, reports are not created for channels that are set to [Skip] or those that have the computation turned [Off].
- Sum scale
Select the sum scale from the following.
Off: $\Sigma(\text{measured/computed data every scan interval})$
/s: $\Sigma(\text{measured/computed data every scan interval}) \times \text{scan interval}$
/min: $\Sigma(\text{measured/computed data every scan interval}) \times \text{scan interval}/60$
/h: $\Sigma(\text{measured/computed data every scan interval}) \times \text{scan interval}/3600$
/day: $\Sigma(\text{measured/computed data every scan interval}) \times \text{scan interval}/86400$

10.7 Starting/Stopping the Report Function

This section explains how to start/stop the report function.

Procedure

The start/stop operation of the creation of reports is synchronized to the start/stop operation of the data acquisition to the internal memory.

Starting the Report Function

Press the **START** key.

The report function starts. When the time to create the report arrives, the report data is written to the internal memory.

As shown in the following figure, the memory operation indicator icon changes from stop indication to run indication. The computation icon is also displayed.

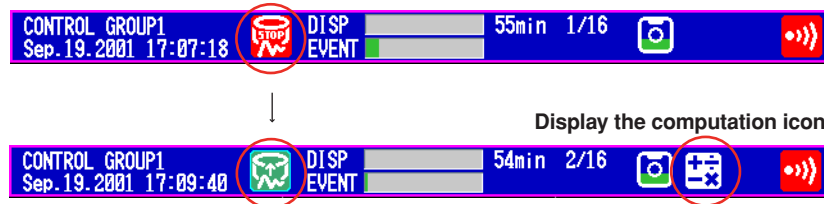

Stopping the Report Function

1. Press the **STOP** key.

The following dialog box appears for confirmation.



2. Select [Mem+Math] or [Memory] using the **left and right arrow keys**.
3. Press the **DISP/ENTER** key.

When data acquisition to the internal memory/computation (report function) stops, the memory operation indicator icon changes from run indication to stop indication.

Note

- If you clear the data in the internal memory (see section 9.7), report data is cleared along with other data (display data).
- Report data is stored to the external storage medium at the same time as when the data is written to the internal memory. For the procedure in setting the storage method, see section 9.1.
- If you stop the report function, the report file on the external storage medium is closed. If you start the report function again, the data is saved to a new file.

11.1 USER Key Assignment and Operation

This section explains how to assign an action to the USER key and how to use the USER key after the action has been assigned.

Procedure

Opening the Action Assignment Setting Display for the User Key

Press the keys in the following sequence:

MENU key (switch to setting mode(control)) > **MENU key** (switch to Set mode) > **#3 soft key** (select [Trend/Save interval,Message,File,User key,DST])

The following display appears.

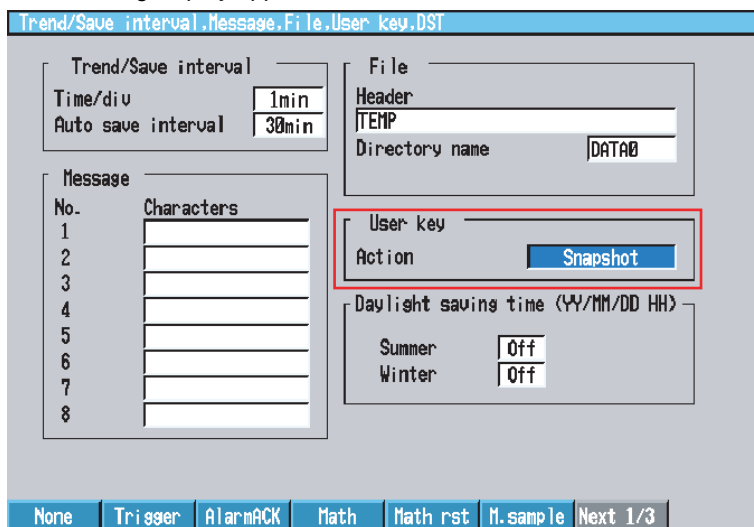

Setting a Action to the USER Key

1. Use the **arrow keys** to move the cursor (blue) to the [Action] box under [User key].
2. Press the **soft key** corresponding to the action you wish to select.
3. Press the **DISP/ENTER key**.

USER Key Operation

Press the USER key once to perform the assigned action in operation mode or Set mode. It does not operate in basic setting mode except the [Snapshot] action, which operates in all modes.

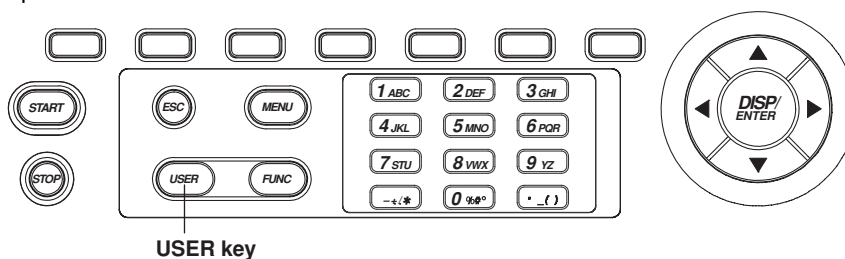

11.1 USER Key Assignment and Operation

Setup Items

Assigning a Function to the USER Key

Select one of the following actions. The initial value is [AlarmACK].

Name of Action	Reference	Action
None	–	No operation.
Trigger	9.1	Supplies a trigger used to start acquiring event data to the internal memory (valid only when event data is specified to be acquired to the internal memory and the trigger used to start the acquisition is set to key trigger).
AlarmACK	4.7, 7.2	Clears the alarm indication/relay output (valid only when the operation of the alarm indication or output relay is set to "Hold").
MathStart/Stop	10.2	Starts/stops computation (only for models with the computation function option (/M1))
MathReset	10.2	Resets the computed data (resets to 0, only on models with the computation function option (/M1) while the computation is stopped).
ManualSample	9.2	Writes the instantaneous values of all channels to the internal memory once.
Message1 to 8	8.9	Displays the message (1 to 8) on the trend display and write it to the internal memory.
Snapshot	9.6	Saves the current screen image data to the external storage medium.

11.2 Key Lock

This section explains how to disable/enable the key operation (including Zip disk ejection and data save operation in manual save mode).

Procedure

Opening the Setting Display

Press the keys in the following sequence:

MENU key (switch to Set mode) > **Hold down the FUNC key for 3 seconds** (switch to basic setting mode) > **#3 soft key** (select [Keylock])

The following display appears.

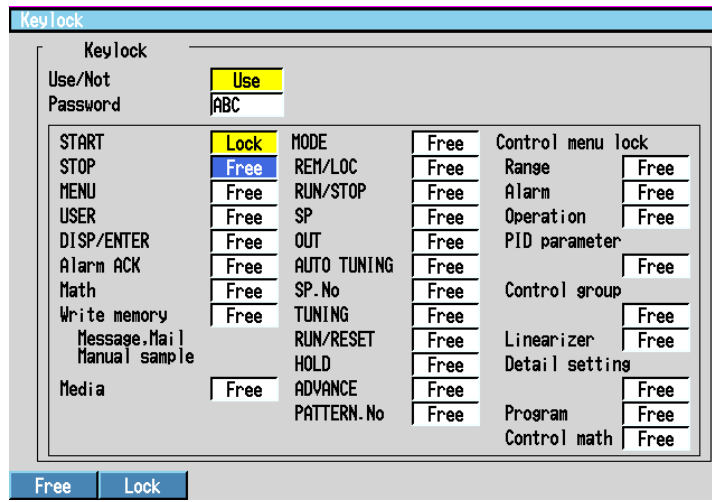

Setup Procedure

1. Use the **arrow keys** to move the cursor (blue) to the item box you wish to change. A soft key menu is displayed at the bottom of the display.
2. Press the **soft key** corresponding to the value you wish to select. The box for the item you changed turns yellow, and the cursor moves to the next item.
3. Repeat steps 1 and 2 to change the value of all the items you wish to change.
4. Press the **DISP/ENTER key** to confirm the changes. The boxes for the items you changed turn from yellow to white, and the cursor returns to the first item box.

Saving the Settings in Basic Setting Mode

1. Press the **ESC key**. The display returns to basic setting menu.
2. Press the **[End] soft key**. A confirmation dialog box appears.
3. Select [Yes] and press the **DISP/ENTER key**. The operation screen is displayed.

Keylock

1. In operation mode, press the **FUNC key**. The soft key menu is displayed. The [Keylock] soft key does not appear if the Keylock Use/Not setting is [Not].

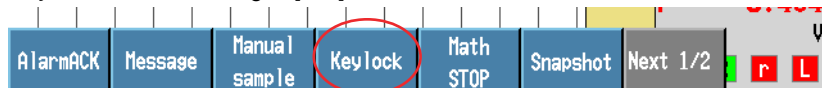

2. Press the **[Keylock] soft key**.
3. Press the **DISP/ENTER key**.

Note

While the keylock function is enabled, a keylock icon (see *section 1.16*) appears in the status indication section. If you press a locked key while the keylock function is enabled, a message “This key is locked” appears.

Releasing the Keylock

1. In operation mode, press the **FUNC key**.
The soft key menu is displayed.



2. Press the **[Keylock] soft key**.
The password entry window appears.
3. Enter the password using the **soft keys** and **character/number input keys**.

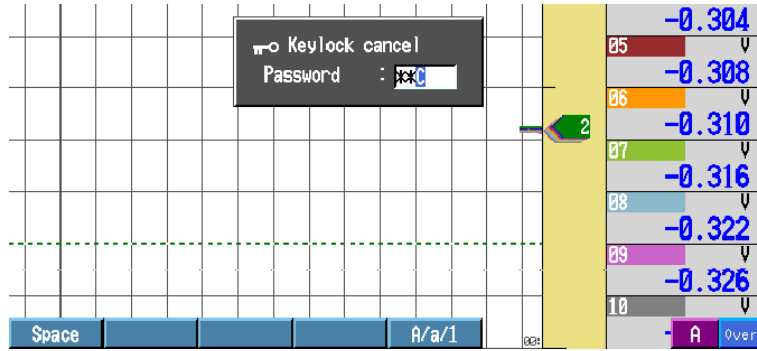

4. Press the **DISP/ENTER key**.

Setup Items

Setting the Keylock

- **Use/Not**
To enable the keylock function select [Use].
- **Password**
Enter the password for releasing the keylock. Set the password using up to 6 characters.
- **Keylock Items**
Select [Lock] to apply the keylock function to the key; select [Free] otherwise.

Keylock Items

- Operation keys other than the FUNC key, arrow keys, and character/number input keys.
- [AlarmACK] soft key.
- [MathSTART], [MathSTOP], and [MathReset] soft keys.
- Soft keys related to memory writing including [Message], [Manual sample], [Trigger], [Save Display], and [Save Event] soft keys.
- E-mail related soft keys including [E-Mail START], [E-Mail STOP], and [E-Mail test] soft keys.
- Prohibit data storage when an external storage medium is inserted during manual save mode and prohibit Zip disk ejection.
- Prohibit Zip disk ejection during auto save mode.

11.3 Key Operation Login/Logout

This section explains how to set the CX2000 so that only certain users can operate the instrument, and how to log in and log out after the function is enabled.

Procedure

Opening the Setting Display

Press the keys in the following sequence:

MENU key (switch to Set mode) > **Hold down the FUNC key for 3 seconds** (switch to basic setting mode) > **#4 soft key** (select [Key login])

The following display appears.

Key login	
Use/Not	Use
Auto logout	Off
UserID Use/Not	Use
Number 1	
On/Off	On
User name	user1
User ID	1
Password	ABC
Enter setup	Enable

Setup Procedure

1. Use the **arrow keys** to move the cursor (blue) to the item boxes.
2. Press the **soft key** to set the values.
3. Press the **DISP/ENTER key**.

Saving the Settings in Basic Setting Mode

1. Press the **ESC key**.
The display returns to basic setting menu.
2. Press the **[End] soft key**.
A confirmation dialog box appears
3. Select [Yes] and press the **DISP/ENTER key**.
The operation screen is displayed.

Login Operation

1. Press the **FUNC key**.
A user name list window and a soft key menu appears.

User name list	
User1 :	user1
User2 :	
User3 :	
User4 :	
User5 :	
User6 :	
User7 :	

Enter setup
Enable

User1

2. Press the **soft key** corresponding to the user to be logged in.

11.3 Key Operation Login/Logout

3. If "UserID Use/Not" is set to "Use" in the key login settings, a User ID entry window appears. Enter the **User ID** and press the **DISP/ENTER key**.

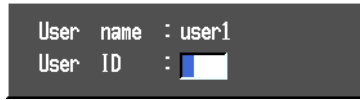

4. A password entry window appears. Enter the **Password** and press the **DISP/ENTER key**.

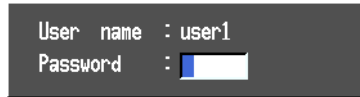

If the password is correct, the user is logged in, and the user name appears in the status indication section as shown below.



Note

When starting/stopping the acquisition of the display data/event data to the internal memory, the user name is written to the respective files. The user name when writing messages is also written to the internal memory.

Logout Operation

- Manual Logout
 1. Press the **FUNC key**.

The soft key menu is displayed.
 2. Press the **[Logout] soft key**.

The user name in the status indication section disappears.
- Auto logout

If the auto logout function is enabled, users are automatically logged out when there is no key operation for 10 minutes in operation mode.

Note

If the CX2000 is switched from basic setting mode to operation mode, the CX2000 is in a logged out condition.

Setup Items

Setting Key Login

- **Use/Not**

To enable the key login function select [Use].
- **Auto logout**

On: Automatically logs the user out if there is no key operation for ten minutes.
Off: The user stays logged on until the user manually logs out.
- **UserID Use/Not**

Set whether to use the User ID when logging in ([Use/Not]). If [Use] is selected, the [User ID] entry box appears.
- **Number**

Select the user registration number from [1] to [7].
- **Off/On**

Select whether to enable [On] or disable [Off] the key login function of the user corresponding to the registration number.

- **User name**
Enter the user name using up to 16 alphanumeric characters. You cannot specify “quit” as a user name. In addition, the user name cannot be set to all spaces. If the user name already exists, a message “This username is already registered.” appears. In this case, change the user name to a unique name.
- **User ID (only when UserID Use/Not is set to [Use])**
Enter the user ID using up to 4 alphanumeric characters.
- **Password**
Set the password using up to 6 characters.
- **Enter setup**
Select whether to allow the user that has logged in to enter basic setting mode ([Enable/Disable]).

Note

You cannot set all users to [Disable]. If you attempt to do so, the user with the smallest registration number is automatically changed to [Enable] at the time the setup data is saved.

11.4 Displaying Logs (Checking Operations) and System Information Display (Checking the System Specifications)

Open the log display when checking the following operation information. Error message, login/logout log, communication command log, FTP file transfer log, E-mail transmission log, and Web browser operation log. To check the specifications of the CX2000 (number of inputs, internal memory size, options, MAC address, and firmware version number), open the system information display. This section explains how to display the above information.

Procedure

Opening the Log Display and System Information Display

1. In operation mode, press the **FUNC** key.
2. Press the **[Next 1/2]** soft key.

A soft key menu including the [Log] soft key appears.



3. Press the **[Log]** soft key.

The following soft key menu is displayed. [Login] and [Web] soft keys appear only when those functions are being used.

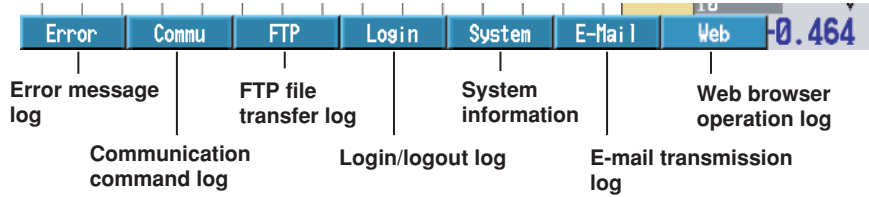

4. Press the **soft key** corresponding to the display you wish to show.

Explanation

Error Message Log

(030/050)	Time	No.	Message
Sep.19.2001	15:18:51	210	Media has not been inserted.
Sep.19.2001	15:11:18	601	Measured data have been initialized.

↑ Date/time when the error occurred ↑ Error code ↑ Error message

For details on error messages, see *chapter 12, "Troubleshooting."*

Login/logout Log

Number of the log displayed at the bottom line/total number of logs

(015/015)	Time	I/O	No.	User Name
Sep.19.2001	17:22:07	In	01	user1
Sep.16.2001	12:45:46	In	01	user1
Sep.15.2001	21:17:54	In	01	user1
Sep.15.2001	18:22:23	In	01	user1
Sep.15.2001	16:59:15	In	01	user1
Sep.15.2001	12:05:16	In	01	user1

↑ In: Key login ↑ User name of the operation
 ↓ Out: Logout

↑ Date/time of key login/logout

Communication Command Log

Number of the log displayed at the bottom line/total number of logs

Connection status indication of the Ethernet interface
 Illuminated (green): Connected electrically
 Not illuminated: Not connected electrically

<007/007>	Time	ID	User Name	I/O	Message	Link
Jan.12.2000	18:52:23	1	user	<	(Logout)	
Jan.12.2000	18:52:23	1	user	>	CC 0	
Jan.12.2000	18:51:48	1	user	<	(259)	
Jan.12.2000	18:51:48	1	user	>	FD 0,001,010	
Jan.12.2000	18:51:41	1	user	<	E0	
Jan.12.2000	18:51:41	1	user	>	B0 0	
Jan.12.2000	18:51:37	1	user	<	(Login)	

Message (up to 20 characters)
 Input/output signal (>: input, <: output)
 Name of the user who accessed the CX2000
 Number identifying the connected user
 Date/time the CX2000 was accessed

FTP File Transfer Log

Number of the log displayed at the bottom line/total number of logs

<005/005>	Time	No.	Code	Flag	File Name
Jan.01.2000	01:50:22	282	HOSTNAME	S	10101500.DDS
Jan.01.2000	01:50:22	282	UNREACH	P	10101500.DDS
Jan.01.2000	01:49:32			P	10101490.DDS
Jan.01.2000	01:48:51			P	10101480.DDS
Jan.01.2000	01:48:27			P	DX_FTPC.TXT

File name (8 characters)
 FTP connection destination (P: primary, S: secondary)
 Error code
 Date/time when file was transferred

Web Browser Operation Log

<004/004>	Time	Request	No.	Parameter
Jan.07.2001	01:19:12	Message	155	2:stop
Jan.07.2001	01:18:29	Message		1:start
Jan.07.2001	01:18:15	Key		UP
Jan.07.2001	01:17:58	Screen		DIGITAL GROUP=1

Operation information
 Error code (See chapter 12.)
 Operation type
 Date/time when the operation was carried out on the Web screen.

11.4 Displaying Logs (Checking Operations) and System Information Display (Checking the System Specifications)

E-mail Transmission Log

(YY/MM) Time	Type	No.	Recipient / Error
Jan. 07. 2001 01:00:24	Full	264	1+2 Some recipients' addresses are in..
Jan. 07. 2001 01:00:01	Time		1 H.S
Jan. 07. 2001 01:00:00	Report		1 H.S
Jan. 07. 2001 00:59:53	Report		1 H.S
Jan. 06. 2001 01:02:21	Alarm		1 H.S

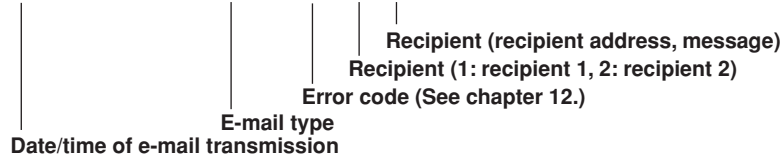

System Information Display

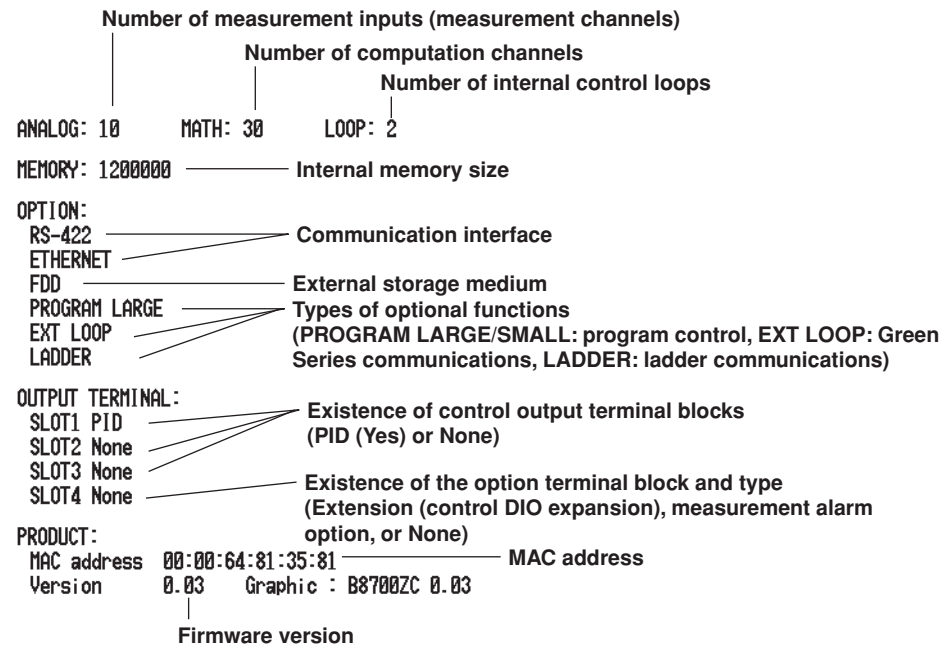

Note

- If the information is displayed using red characters on the system information display, there is a possibility that the CX2000 has malfunctioned. In such case, contact your nearest YOKOGAWA dealer.
- Even if the transmitter power supply output terminal block (/TPS4 option) is installed, [None] is displayed at [SLOT4] under [OUTPUT TERMINAL].

11.5 Setting the Measurement Remote Input (/A6R option or /A4FR option)

This section explains how to assign a particular action to the remote input terminal [REMOTE] of the measurement alarm option terminal block.

Procedure

Opening the Operation Display

Press the keys in the following sequence:

MENU key (switch to Set mode) > **Hold down the FUNC key for 3 seconds** (switch to basic setting mode) > **#6 soft key** (select [Option])

The following display appears.

The screenshot shows the 'Option' menu with three main sections: Remote, Report, and Timer (TLOG). The Remote section is highlighted with a red box and contains a table with 8 rows. The Report section contains four settings. The Timer (TLOG) section contains a table with 3 rows. At the bottom, there is a row of soft keys: None, StartStop, Trigger, AlarmACK, Time adj, Math, and Next 1/4.

Remote	
No.	Action
1	MemoryStart/Stop
2	Trigger
3	AlarmACK
4	TimeAdjust
5	MathStart/Stop
6	MathReset
7	MemoryStart/Stop
8	Trigger

Report	
Report set	Off
Report CH	R01
On/Off	On
Channel	01
Sum scale	/s

Timer (TLOG)					
No.	Mode	Interval	Ref. time	Reset	Action
1	Absolute	1h	0:00	Off	Off
2	Off				
3	Off				

None StartStop Trigger AlarmACK Time adj Math Next 1/4

Operations on the Display

1. Use the **arrow keys** to move the cursor (blue) to the item box you wish to change. A soft key menu is displayed at the bottom of the display.
2. Press the **soft key** corresponding to the value you wish to select. The box for the item you changed turns yellow, and the cursor moves to the next item.
3. Repeat steps 1 and 2 to change the value of all the items you wish to change.
4. Press the **DISP/ENTER key** to confirm the changes. The boxes for the items you changed turn from yellow to white, and the cursor returns to the first item box.

Saving the Settings in Basic Setting Mode

1. Press the **ESC key**. The display returns to basic setting menu.
2. Press the **[End] soft key**. A confirmation dialog box appears.
3. Select [Yes] and press the **DISP/ENTER key**. The operation screen is displayed.

Setup Items

Measurement Remote

• **Action**

Select the action to be assigned from the following. Select [None] if you are not assigning any action.

MemoryStart/Stop

- Remote input signal: Rising edge signifies start; falling edge signifies stop
- Start
Starts the acquisition of the display data/event data to the internal memory and the report function (computation function option).
- Stop
Stops the acquisition of the display data/event data to the internal memory and the report function (computation function option).
- If the data acquisition is started, applying a rising signal produces no effect. If the data acquisition is stopped, applying a falling signal produces no effect.

Trigger

- Remote input signal: Trigger, 250 ms or more.
- This input is used as an external trigger for starting the acquisition of the event data to the internal memory.
This is valid only when acquiring the event data to the internal memory using the trigger or rotate mode, when the acquisition start trigger is set to external trigger, and when the CX2000 is in the trigger wait state. For all other cases, applying the remote signal produces no effect.

AlarmACK

- Remote input signal: Trigger, 250 ms or more.
- Releases the alarm indication and relay output (option). This is the same function as when the [AlarmACK] soft key is pressed.

TimeAdjust

- Remote input signal: Trigger, 250 ms or more.
- Adjusts the internal clock of the CX2000 to the nearest hour depending on the time when the remote signal is applied.

Time When Signal Is Input	Modified Time
00 min 00 s to 01 min 59 s	Truncates the minutes and seconds. Example: 10 hours 01 min 50 s becomes 10 hours 00 min 00 s.
02 min 00 s to 57 min 59 s	The time is not changed.
58 min 00 s to 59 min 59 s	Rounds up the minutes and seconds. Example: 10 hours 59 min 50 s becomes 11 hours 00 min 00 s.

MathStart/Stop

- Remote input signal: Rising edge signifies start; falling edge signifies stop.
- Starts/stops the computation. This is valid only on models with the computation function option.
- If the computation is started, applying a rising signal produces no effect. If the computation is stopped, applying a falling signal produces no effect.

MathReset

- Remote input signal: Trigger, 250 ms or more.
- Resets the data on all computation channels. This is valid only on models with the computation function option and while the computation is stopped. For all other cases, applying the remote input signal produces no effect.

Manual sample

- Remote input signal: Trigger, 250 ms or more.
- Write the instantaneous values of all channels to the internal memory once. This excludes measurement channels set to skip and computation channels set to Off.

Panel1Load to Panel3Load

- Remote input signal: Trigger, 250 ms or more.
- Loads the setup data file named "LOAD1.PCL", "LOAD2.PCL", or "LOAD3.PCL" stored on the external storage medium and activates the settings. Setup data files named "LOAD1.PCL", "LOAD2.PCL", or "LOAD3.PCL" must be created and saved to the external storage medium beforehand.

Message1 to Message8

- Remote input signal: Trigger, 250 ms or more.
- Displays a message at the position corresponding to the time when the signal was applied on the trend display. The displayed message is also written to the internal memory.

When data acquisition to the internal memory is stopped, messages cannot be displayed or written. Applying a remote input signal produces no effect.

Snapshot

- Remote input signal: Trigger, 250 ms or more.
- Saves the current screen image data to the external storage medium. The snapshot function operates in all modes (operation mode, setting mode, and basic setting mode). Error messages, even if they are displayed, are not saved.

11.6 Setting Whether or Not to Use the Batch Header (/BT1 option)

Procedure

This section explains how to be available batch header .

Opening the Operation Display

Press the keys in the following sequence:

MENU key (switch to Set mode) > **Hold down the FUNC key for 3 seconds** (switch to basic setting mode) > **#9 soft key** (select [Option])

The following display appears.

AUX, Time zone	
AUX	
Tag/Channel	Tag
Memory alarm	1h
Language	English
Partial	Not
Batch	Use
Time zone	
Difference from GMT	0
Use	Not

Operations on the Display

1. Use the **arrow keys** to move the cursor (blue) to [Batch].
[Use] and [Not] soft keys are displayed at the bottom of the display.
2. Press the **soft key** corresponding to the value you wish to select.
The box for the item you changed turns yellow, and the cursor moves to the next item.
3. Press the **DISP/ENTER key** to confirm the changes.
The boxes for the items you changed turn from yellow to white, and the cursor returns to the first item box.

Saving the Settings in Basic Setting Mode

1. Press the **ESC key**.
The display returns to basic setting menu.
2. Press the **[End] soft key**.
A confirmation dialog box appears
3. Select [Yes] and press the **DISP/ENTER key**.
The operation screen is displayed.

11.7 Setting the Batch Information (/BT1 option)

This section explains how to set the items that are attached to the data acquired in the internal memory.

In addition you can set whether or not to use the following functions:

- Automatically increment the lot number at the end of the batch.
- Display the batch number and lot number for each file in place of the date and time the data acquisition ended, on the memory summary screen.

Procedure

Opening the Operation Display

Press the keys in the following sequence:

MENU key (switch to Set mode) > > **MENU key** (switch to Set mode) > **#9 soft key** (select [Batch set])

The following display appears.

Batch set	
Batch	
Application name	TEST2000
Supervisor name	YOKOGAWA
Manager name	CK2000
Batch number	A100
Lot number	2
Auto increment	On
Disp information	Time

Input Clear Copy

Operations on the Display

1. Use the **arrow keys** to move the cursor (blue) to [Batch].
[Use] and [Not] soft keys are displayed at the bottom of the display.
2. Press the **soft key** corresponding to the value you wish to select.
The box for the item you changed turns yellow, and the cursor moves to the next item.
3. Press the **DISP/ENTER key** to confirm the changes.
The boxes for the items you changed turn from yellow to white, and the cursor returns to the first item box.

Saving the Settings in Basic Setting Mode

1. Press the **ESC key**.
The display returns to basic setting menu.
2. Press the **[End] soft key**.
A confirmation dialog box appears
3. Select [Yes] and press the **DISP/ENTER key**.
The operation screen is displayed.

11.7 Setting the Batch Information (BT1 option)

Setup Items

Application name

Enter the application name (up to 16 characters).

Supervisor name

Enter the supervisor name (up to 16 characters).

Manager name

Enter the manager name (up to 16 characters).

Batch number

Enter the batch number (up to 16 characters).

Lot number

Enter the lot number (0-9999).

Auto increment (Automatic increment of the lot number)

Set whether or not to automatically increment the lot number (to the next lot number) when the data acquisition to the internal memory is complete.

[On]: Automatically increment the lot number when the data acquisition is complete.

[Off]: Do not change the lot number.

Note

The lot number after 9999 is 0.

Disp information (Displayed information of the stored data)

Set whether to display the batch number and lot number or the date and time of file creation on the memory summary, display data load, and event data load screens.

[Batch]: Display the batch number and lot number.

[Time]: Display the date and time of file creation.

11.8 Setting the Batch Information (/BT1 option)

This section explains how to set the items that are attached to the data acquired in the internal memory.

In addition you can set whether or not to use the following functions:

- Automatically increment the lot number at the end of the batch.
- Display the batch number and lot number for each file in place of the date and time the data acquisition ended, on the memory summary screen.

Procedure

1. Press the FUNC key to display the soft key menu.
2. Press the [Batch] soft key to display the Batch setting display.

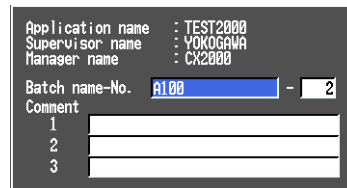

```
Application name : TEST2000
Supervisor name : YOKOGAWA
Manager name    : CX2000

Batch name-No.  R100 - 2
Comment
1
2
3
```

3. Use the **arrow keys** to move the cursor (blue) to the item box you wish to change. A soft key menu is displayed at the bottom of the display.
4. Enter the [Batch name-No.] and [Comments] using the **character/number input key**.
5. Press the **DISP/ENTER key**.

Setup Items

Batch number

Enter the batch number (up to 16 characters).

Lot number

Enter the lot number (0-9999).

Comment

The comment, the name of the user that entered the comment (only when the key login function is enabled), and the date and time when the comment was entered are written to the internal memory along with the measured/computed data. The comment is cleared when the data acquisition to the internal memory is stopped.

You can set three comments.

12.1 Messages

Error messages for communication commands are output in English.

Errors Related to Parameter Settings

• Setting Errors

Code	Message	Explanation/Countermeasures/Ref. section
1	System error.	Contact your nearest YOKOGAWA dealer.
2	Incorrect date or time setting.	See section 3.3.
3	A disabled channel is selected.	See the Communication Interface User's Manual.
4	Incorrect function parameter.	See the Communication Interface User's Manual.
5	The input numerical value exceeds the set range.	Enter a proper value.
6	Incorrect input character string.	Enter a proper character string.
7	Too many characters.	Enter the correct number of characters.
8	Incorrect input mode.	See the Communication Interface User's Manual.
9	Incorrect input range code.	See the Communication Interface User's Manual.
10	A disabled loop number is selected.	See the Communication Interface User's Manual.
11	A disabled module number is selected.	See the Communication Interface User's Manual.
12	A disabled input kind is selected.	See the Communication Interface User's Manual.
13	A disabled pid number is selected.	See the Communication Interface User's Manual.
14	A disabled segment number is selected.	See the Communication Interface User's Manual.
21	Cannot set an alarm for a skipped channel.	See the Communication Interface User's Manual.
22	The upper and lower span limits are equal.	See sections 4.6 and 7.1.
23	The upper and lower scale limits are equal.	See sections 4.6 and 7.1.
30	The partial boundary value exceeds the range of the span.	See section 8.14.
31	Partial-expansion display is set ON for a SKIPPED channel.	See the Communication Interface User's Manual.
35	The upper and lower limits of the display band are equal.	See section 8.12.
36	The lower limit of the display band is greater than the upper limit.	See section 8.12.
37	The display band is narrower than 4% of the entire display.	See section 8.12.
40	Incorrect group set character string.	See sections 6.1 and 8.3.
41	There is no specified input channel.	See the Communication Interface User's Manual.
42	Exceeded the number of channels which can be set.	See the Communication Interface User's Manual.
43	A channel number cannot repeat in a group.	See section 8.3.
45	There is no character string saved in the clipboard.	Copy a character string to the clipboard.
46	The character string saved in the clipboard is too long.	Paste a character string with the specified number of characters.
61	There is no channel specified by the MATH expression.	See section 10.1.
62	MATH expression grammar is incorrect.	See section 10.1.
63	MATH expression sequence is incorrect.	See section 10.1.
64	MATH upper and lower span values are equal.	See section 10.1.
70	The range of the MATH constant is exceeded.	See section 10.1.
71	Set range of the MATH constant is exceeded.	See section 10.1.
81	All space or 'quit' string cannot be specified.	See section 11.3.
85	The login password is incorrect.	See section 11.3.
86	The key-lock release password is incorrect.	See section 11.2.
87	This key is locked.	See section 11.2.
88	This function is locked.	See section 11.2.
89	Press [FUNC] key to login.	See section 11.3.
90	No permission to enter to the SETUP mode.	See section 11.3.
91	Password is incorrect.	See sections 11.2 and 11.3.

12.1 Messages

Code	Message	Explanation/Countermeasures/Ref. section
92	Press [ESC] key to change to operation mode.	Press the ESC key.
93	String including space or all space cannot be specified.	Spaces are not allowed in the Web browser user name and password.
94	More than one address cannot be specified.	Only a single sender is allowed.
100	IP address doesn't belong to class A, B, or C.	See the Communication Interface User's Manual.
101	The result of the masked IP address is all 0s or 1s.	See the Communication Interface User's Manual.
102	SUBNET mask is incorrect.	See the Communication Interface User's Manual.
103	The net part of default gateway is not equal to that of IP address.	See the Communication Interface User's Manual.
104	FTP client failed because the memory mode is 'manual'.	See the Communication Interface User's Manual.
120	The start segment number is greater than the end segment number.	See section 5.6.
121	The On-time is greater than the Off-time.	See section 5.5.
122	Exceeded the number of events which can be set.	See section 5.5.
130	The lower span limit is greater than the upper span limit.	See section 4.6.
131	The range of the span is wider than 30000.	See section 4.6.
132	The lower scale limit is greater than the upper scale limit.	See section 4.6.
133	The range of the scale is wider than 30000.	See section 4.6.
134	The lower and upper span limits of the PV range are equal.	See section 4.6.
135	The lower span limit of the PV range is greater than the upper span limit.	See section 4.6.
136	The range of the PV range is wider than 30000.	See section 4.6.
137	The lower span limit of the PV switching exceeds the PV range.	See section 4.6.
138	The upper span limit of the PV switching exceeds the PV range.	See section 4.6.
139	The lower and upper span limits of the PV switching are equal.	See section 4.6.
140	The lower span limit of the PV switching is greater than the upper span limit.	See section 4.6.
141	The lower and upper limits of the output are equal.	See section 4.9.
142	The lower limit of the output is greater than the upper limit.	See section 4.9.
143	The lower and upper limits of the target setpoint are equal.	See section 4.12.
144	The lower limit of the target setpoint is greater than the upper limit.	See section 4.12.
145	The setting of the reference point is incorrect.(n.RP > n+1.RP)	See section 4.8.
146	Incorrect input I/O data. (Set point number < 2)	See section 4.11.
147	Incorrect input I/O data. (Output(n-1) > Output(n))	See section 4.11.
148	Incorrect input I/O data. Input+Output exceeds the range.	See section 4.11.
149	Incorrect input I/O data. (Input+Output(n-1) > Input+Output(n))	See section 4.11.

• Execution Errors

Code	Message	Explanation/Countermeasures/Ref. section
150	This action is not possible because sampling is in progress.	See section 9.1.
151	This action is not possible during sampling, calculating or controlling.	See section 9.1.
152	This action is not possible because saving is in progress.	Wait until the saving ends.
153	This action is not possible because formatting is in progress.	Wait until the formatting ends.
155	The message is not written while sampling is stopped.	See sections 8.9 and 9.1.
160	Cannot load the specified data. Change the memory setting.	See section 9.3.
165	Auto setting is not possible because the target is not support.	Use manual setting instead of auto setting. See the Communication Interface User's Manual.
166	This action is not possible because communication protocol is not "Modbus-M".	Set the communication setting to "Master." (See the Communication Interface User's Manual.)

Operation Errors

• Errors Related to the External Storage Medium

Code	Message	Explanation/Countermeasures/Ref. section
200	Operation aborted because an error was found in media.	See the Communication Interface User's Manual.
201	Not enough free space on media.	Use another storage medium.
202	Media is read-only.	Release the write protection.
210	Media has not been inserted.	Insert a storage medium into the drive.
211	Media is damaged or not formatted.	Use another storage medium or carry out formatting.
212	Format error.	Try formatting again or use another storage medium.
213	The file is read-only.	Access another file or write-enable the file.
214	There is no file or directory.	See the Communication Interface User's Manual.
215	Exceeded the allowable number of files.	Use another storage medium. Delete unneeded files.
216	The file or directory name is incorrect.	See sections 9.1 and 9.3.
217	Unknown file type.	Specify another file.
218	Directory exists. Delete the directory or change directory name.	See section 9.1.
219	Invalid file or directory operation.	Tried to delete multiple directory levels.
220	The file is already in use. Try again later.	Wait until the file is accessible.

• Errors Related to the Historical Trend

Code	Message	Explanation/Countermeasures/Ref. section
230	There is no setting file.	Specify another file.
231	Abnormal setting exists in file.	Specify another file.
232	There is no available data.	Appears when displaying historical trends. Specify another file.
233	The specified historical data do not exist.	Appears when switching to historical trend from information display. See section 8.1.
234	The specified channel is not assigned to the display group.	Appears when switching to trend or bar graph from overview. See section 8.6.

12.1 Messages

• Errors Related to E-mail and Web Server

Code	Message	Explanation/Countermeasures/Ref. section
260	IP address is not set or ethernet function is not available.	The IP address is not specified. Check the IP address.
261	SMTP server is not found.	Occurs when the SMTP server is specified by name. <ul style="list-style-type: none">• Check the DNS setting.• Check the SMTP server name.
262	Cannot initiate E-mail transmission.	<ul style="list-style-type: none">• The host name of the DAQSTATION is not correct. Check the host name.• The port number of the SMTP server is not correct. Check the port number.
263	Sender's address rejected by the server.	Check the sender's address.
264	Some recipients' addresses are invalid.	Check the recipient's address.
265	SMTP protocol error.	May occur if a network failure (cable problems, duplicate addresses, network device failure, and so on) occurs in the middle of the e-mail transmission.
266	Ethernet cable is not connected.	Check the cable connection.
267	Could not connect to SMTP server	<ul style="list-style-type: none">• Check to see that the SMTP server is connected to the network.• If the SMTP server name is specified using an IP address, check to see that the IP address is correct.
268	E-mail transmission request failed.	Contact your nearest YOKOGAWA dealer.
269	E-mail transfer error.	May occur if a network failure (cable problems, duplicate addresses, network device failure, and so on) occurs in the middle of the e-mail transmission.
275	The current image cannot be output to the Web.	The setting display cannot be shown on the Web browser. This message is displayed on the Web browser.
276	Image data currently being created. Unable to perform key operation.	Try again a little later. This message is displayed on the Web browser.
277	Could not output screen to Web.	Failed to create the image. This message is displayed on the Web browser.

• Errors Related to FTP Client

For information regarding the FTP client function of the CX2000, see the *DAQSTATION CX1000/CX2000 Communication Interface User's Manual (IM 04L31A01-17E)*. The detail code does not appear in the error message on the screen. You can view the code on the FTP log display of the CX2000 or using the FTP log output via communications.

Code	Message
280	<p>IP address is not set or FTP function is not available. Further details are provided by the character string that appears after error code 280.</p> <hr/> <p>Character String and Details</p> <hr/> <p>HOSTADDR The IP address of the CX2000 has not been specified. Check the IP address.*¹</p> <p>DORMANT Internal processing error.*²</p> <p>LINK Data link is disconnected. Check the cable connection.</p>
281	<p>FTP mail box operation error. Further details are provided by the character string that appears after error code 281.</p> <hr/> <p>Character String and Details</p> <hr/> <p>MAIL Internal processing error.*²</p> <p>STATUS Internal processing error.*²</p> <p>TIMEOUT Internal processing error.*²</p> <p>PRIORITY Internal processing error.*²</p> <p>NVRAM Internal processing error.*²</p>
282	<p>FTP control connection error. Further details are provided by the character string that appears after error code 282.</p> <hr/> <p>Character String and Details</p> <hr/> <p>HOSTNAME Failed the DNS lookup (search the IP address corresponding to the host name). Check the DNS setting and the destination host name.*¹</p> <p>TCP/IP Internal processing error.*²</p> <p>UNREACH Failed to connect to a control connection server. Check the address setting and that the server is running.</p> <p>OOBINLINE Internal processing error.*²</p> <p>NAME Internal processing error.*²</p> <p>CTRL The control connection does not exist. Check that the server does not drop the connection and that it responds within the proper time period.</p> <p>IAC Failed to respond in the TELNET sequence. Check that the server does not drop the connection and that it responds within the proper time period.</p> <p>ECHO Failed to transmit data on the control connection. Check that the server does not drop the connection and that it responds within the proper time period.</p> <p>REPLY Failed to receive data on the control connection. Check that the server does not drop the connection and that it responds within the proper time period.</p> <p>SERVER The server is not in a condition to provide the service. Check that the server is in a condition in which service can be provided.</p>

12.1 Messages

Code	Message
------	---------

283	FTP command was not accepted. Further details are provided by the character string that appears after error code 283.
-----	--

Character String and Details

USER

Failed user name verification.
Check the user name setting.^{*1}

PASS

Failed password verification
Check the password setting.^{*1}

ACCT

Failed account verification.
Check the account setting.^{*1}

TYPE

Failed to change the transfer type.
Check that the server supports the binary transfer mode.

CWD

Failed to change the directory.
Check the initial path setting.^{*1}

PORT

Failed to set the transfer connection.
Check that the security function is disabled.

PASV

Failed to set the transfer connection.
Check that the server supports PASV commands.

SCAN

Failed to read the transfer connection settings.
Check that proper response to the PASV command is received from the server.

284	FTP transfer setting error. Further details are provided by the character string that appears after error code 284.
-----	--

Character String and Details

MODE

Internal processing error.^{*2}

LOCAL

Internal processing error.^{*2}

REMOTE

The destination file name is not correct.
Check that you have the authority to create or overwrite files.

ABORT

File transfer abort was requested by the server.
Check the server for the reason for the abort request.

285	FTP data connection error. Further details are provided by the character string that appears after error code 285.
-----	---

Character String and Details

SOCKET

Failed to create a socket for the transfer connection.^{*3}

BIND

Failed the transfer connection command.^{*3}

CONNECT

Failed the transfer connection.^{*3}

LISTEN

Failed the transfer connection reception.^{*3}

ACCEPT

Failed to accept the transfer connection.^{*3}

SOCKNAME

Internal processing error.^{*2}

RECV

Failed to receive data over the transfer connection.^{*3}

SEND

Failed to send data over the transfer connection.^{*3}

286	FTP file transfer error.
-----	--------------------------

^{*1} See the *DAQSTATION CX1000/CX2000 Communication Interface User's Manual (IM 04L31A01-17E)*.

^{*2} Contact your nearest YOKOGAWA dealer.

^{*3} These errors may occur if the network experiences trouble during the data transmission (bad cable connection, duplicate addresses, network equipment failure).

Note

- The FTP client function on the CX2000 has a timer function that drops the connection if there is no data transfer for two minutes. If the server does not respond within this time period, the transfer fails.
- If the FTP client function on the CX2000 detects a file with the same name at the destination, the file is transferred with the last character (8th character) of the file name changed.
- For information regarding the FTP client function of the CX2000, see the *DAQSTATION CX1000/CX2000 Communication Interface User's Manual (IM 04L31A01-17E)*.

Communication Errors

For information regarding the communication function of the CX2000, see the *DAQSTATION CX1000/CX2000 Communication Interface User's Manual (IM 04L31A01-17E)*.

- **Errors during Setting and Basic Setting Modes, Output Communication Command Execution, and Setup Data Loading**

Code	Message
300	Command is too long.
301	Too many number of commands delimited with ','.
302	This command has not been defined.
303	Data request command can not be enumerated with sub-delimiter.
350	Command is not permitted to the current user level.
351	This command cannot be specified in the current mode.
352	The option is not installed.
353	This command cannot be specified in the current setting.
354	This command is not available during sampling, calculating or controlling.
357	The setup output command cannot be executed in this conditions.

- **Memory Access Errors during Setting and Basic Setting Modes and Output Communication Command Execution**

An English error message is returned via the communication interface. It is not displayed on the screen.

Code	Message
360	Output interface must be chosen from Ethernet or RS by using 'XO' command.
361	The memory data is not saved for the communication output.
362	There are no data to send 'NEXT' or 'RESEND'.
363	All data have already been transferred.
370	Command is not permitted to the current model.

- **Maintenance and Test Communication Command Errors**

An English error message is returned via the communication interface. It is not displayed on the screen.

Code	Message
390	Command error.
391	Delimiter error.
392	Parameter error.
393	No permission.
394	No such connection.
395	Use 'quit' to close this connection.
396	Failed to disconnect.
397	No TCP control block.

12.1 Messages

• Other Communication Errors

An English error message is returned via the communication interface. It is not displayed on the screen.

Code	Message
400	Input username.
401	Input password.
402	Select username from 'admin' or 'user'.
403	Login incorrect, try again!
404	No more login at the specified level is acceptable.
410	Login successful. (The special user level)
411	Login successful. (The general user level)
420	Connection has been lost.
421	The number of simultaneous connection has been exceeded.
422	Communication has timed-out.

Note

For information regarding the communication function of the CX2000, see the *DAQSTATION CX1000/CX2000 Communication Interface User's Manual (IM 04L31A01-17E)*.

Status Messages

Code	Message
500	Execution is complete.
501	Please wait a moment...
503	Data are being saved to media...
504	File is being loaded from media...
505	Formatting...
506	Memory save to media was interrupted.
507	Exchange media to continue the saving operation.
508	There is no file or directory.
510	Range cannot be changed during sampling or calculating.
511	MATH expression cannot changed during sampling, calculating or controlling.
512	Because memory save is 'manual' mode, FTP is not available.
520	Connecting to the line...
521	The data file is being transferred.
530	Setting data cannot be saved during output of setting data.
551	FTP test is being executed...
560	Range cannot be changed during sampling, calculating or controlling.
561	The Output calibration value is being writing...
562	Control function cannot be changed during sampling, calculating or controlling.
563	Hysteresis cannot be changed during sampling, calculating or controlling.
564	Program parameter cannot be changed during FE4 executing.
565	Grayed Items cannot be changed during program pattern operation.
566	The specified data cannot be loaded during FE4 executing.
567	When segment or setting method is changed data in the setting is initialized.
568	The specified data cannot be loaded during program operation.

Warning Messages

Code	Message	Reference
600	Measured data and Settings have been initialized.	–
601	Measured data have been initialized.	–
610	This username is already registered.	See section 11.3.

Code	Message	Reference
611	There is no user who can enter to the SETUP mode.	See section 11.3.
620	You must exit setup mode in order for the communications settings to take effect.	

Control Operation Error Messages

Code	Message	Explanation/Countermeasures/Ref. section
700	Specified loop number cannot be selected	Contact input error (section 4.2), communication error (see the Communication Interface User's Manual)
701	Manual mode cannot be selected.	Contact input error (section 4.2), communication error (see the Communication Interface User's Manual)
702	Cascade mode cannot be selected.	Operation error (section 6.1), Contact input error (section 4.2), communication error (see the Communication Interface User's Manual)
703	Stop mode cannot be selected.	Contact input error (section 4.2), communication error (see the Communication Interface User's Manual)
704	Run mode cannot be selected.	Contact input error (section 4.2), communication error (see the Communication Interface User's Manual)
705	Remote mode cannot be selected.	Contact input error (section 4.2), communication error (see the Communication Interface User's Manual)
706	There is no specified target setpoint number.	Contact input error (section 4.2), communication error (see the Communication Interface User's Manual)
710	Auto-tuning cannot be activated.	Operation error (section 6.1), Contact input error (section 4.2), communication error (see the Communication Interface User's Manual)
711	Auto-tuning is activated already.	Operation error (section 6.1), Contact input error (section 4.2), communication error (see the Communication Interface User's Manual)
712	Incorrect PID group number.	Contact input error (section 4.2), communication error (see the Communication Interface User's Manual)
714	Program mode cannot be selected.	Contact input error (section 4.2), communication error (see the Communication Interface User's Manual)
715	There is no specified pattern number.	Contact input error (section 4.2), communication error (see the Communication Interface User's Manual)
716	Pattern number cannot be changed when program operation is activated.	Contact input error (section 4.2), communication error (see the Communication Interface User's Manual)
717	There are no loops with program operation.	Contact input error (section 4.2), communication error (see the Communication Interface User's Manual)
718	Program operation has started already.	Contact input error (section 4.2), communication error (see the Communication Interface User's Manual)
719	Program operation cannot be started.	Contact input error (section 4.2), communication error (see the Communication Interface User's Manual)
720	A disabled start segment number is selected.	Contact input error (section 4.2), communication error (see the Communication Interface User's Manual)
721	Program operation cannot be started when auto-tuning is activated.	Contact input error (section 4.2), communication error (see the Communication Interface User's Manual)
722	Program operation cannot be started with PV.	Contact input error (section 4.2), communication error (see the Communication Interface User's Manual)
723	Program operation is not activated.	Contact input error (section 4.2), communication error (see the Communication Interface User's Manual)
724	Can not operate in the present situation.	Operation error (section 6.1), Contact input error (section 4.2), communication error (see the Communication Interface User's Manual)
725	Modbus Communication Error.	See the Communication Interface User's Manual.
726	The specified target is not assigned to the control group.	Specify another loop.
729	Can not operation before the starting time of program pattern.	

12.1 Messages

System Errors

Servicing is required when a system error occurs. Contact your nearest YOKOGAWA dealer for repairs.

Code	Message
901	ROM failure.
902	RAM failure.
910	A/D memory failure for all input channels.
911	Channel 1 A/D memory failure.
912	Channel 2 A/D memory failure.
913	Channel 3 A/D memory failure.
914	Channel 4 A/D memory failure.
921	Channel 1 A/D calibration value error.
922	Channel 2 A/D calibration value error.
923	Channel 3 A/D calibration value error.
924	Channel 4 A/D calibration value error.
930	Memory acquisition failure.
940	The Ethernet module is down.
950	First module-channel1 output calibration value can not write.
951	First module-channel2 output calibration value can not write.
952	Second module-channel1 output calibration value can not write.
953	Second module-channel 2 output calibration value can not write.
954	Third module-channel 1 output calibration value can not write.
955	Third module-channel 2 output calibration value can not write.
990	Control AD calibration error.
991	Analog output calibration error.
992	PID module error.

12.2 Troubleshooting Flow Chart

When Nothing Operates (Nothing Is Displayed)

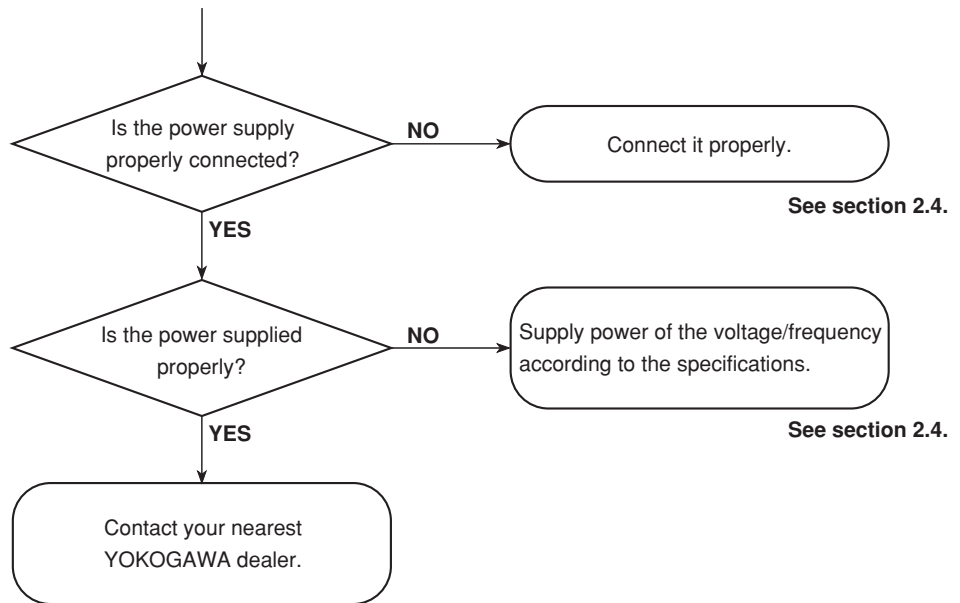

When Problems Exist on the Display or Other Functions

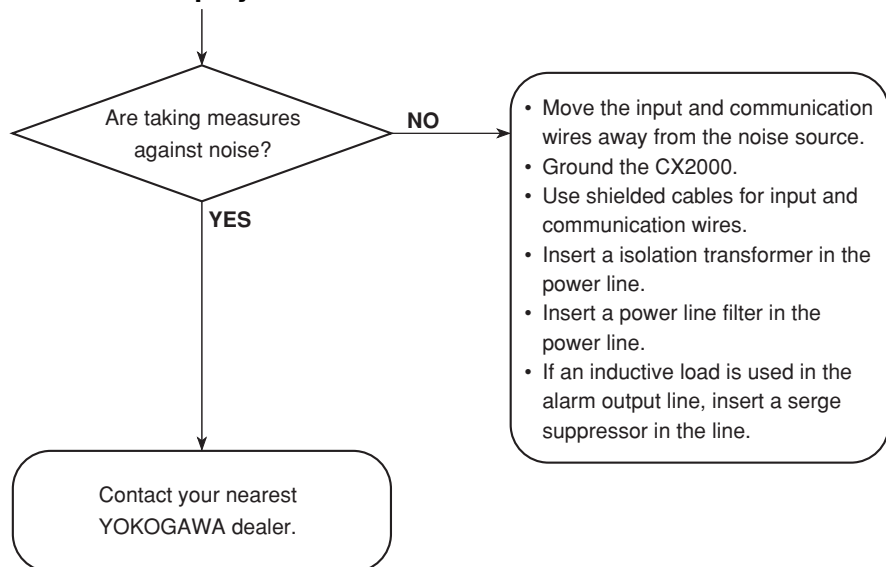

When the Control Output Is Generated

When checking the control output, set the preset output first (see section 4.9). Then, use single loop control with the operation stopped.

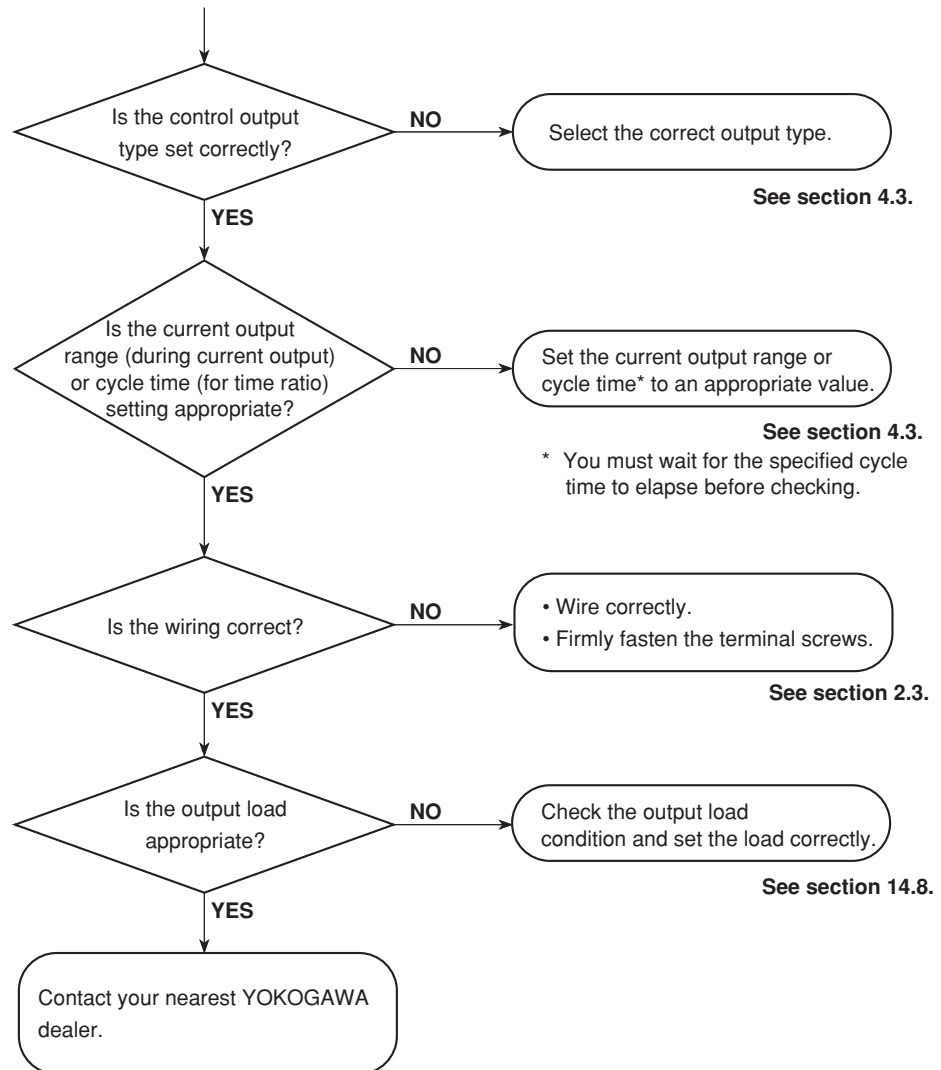

Measurement-Related Problems

In the following cases:

- The reading error is large.
- The trend or digital value fluctuates.
- The trend is off the scale on either the 0% or 100% side.

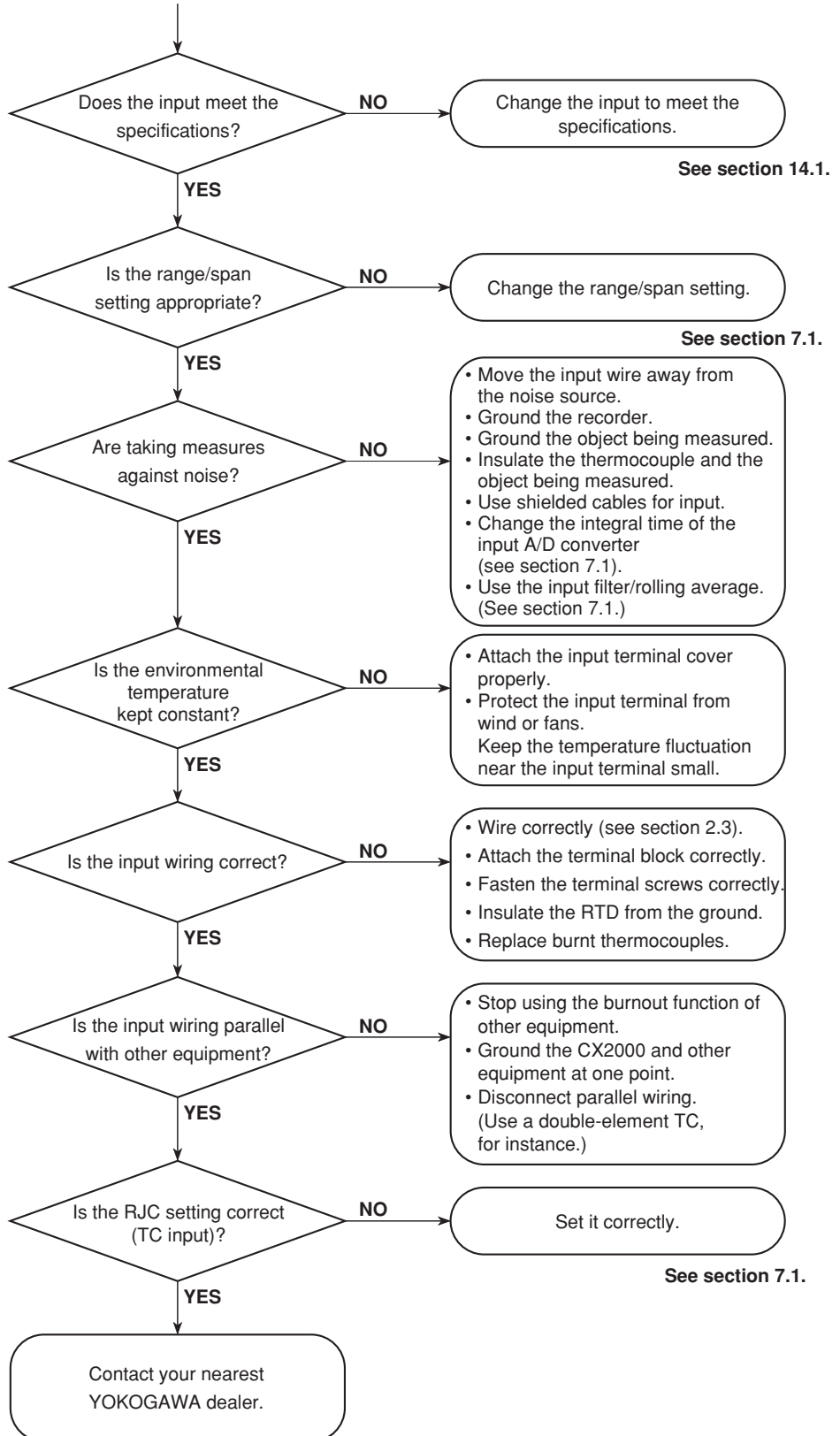

13.1 Periodic Inspection

Check the operation of the CX2000 periodically to keep it in good working order. Conduct the following inspections, and replace worn parts as necessary.

- Is the display and storage functioning properly?
In the event of problems, see *section 12.2, "Troubleshooting Flow Chart."*
- Has the brightness of the LCD backlight deteriorated?
If replacement is necessary, see *section 13.3, "Replacement of Parts."*

13.2 Calibration

It is recommended that the CX2000 be calibrated once a year to assure its measurement accuracy. For details regarding calibration, contact your nearest YOKOGAWA dealer for details.

Required Instruments

A calibration instrument with an appropriate resolution is required for calibrating the CX2000.

Recommended Instrument

- DC voltage standard: YOKOGAWA Model 2552 or equivalent
Main specifications
Accuracy for the range of 20 mV to 20 V: $\pm 0.005\%$
- Decade resistance box: Yokogawa M&C Model 2793-01 or equivalent
Main specifications
Accuracy for the output range of 0.1 to 500 Ω : ($\pm 0.001\% + 2 \text{ m}\Omega$)
Resolution: 0.001 Ω

For information on purchasing the calibration instruments, contact your nearest YOKOGAWA dealer.

Calibration Procedure

1. Wire the CX2000 and the calibration instrument as shown in the following figure, and adequately warm up the instruments (the warm-up time of the CX2000 is at least 30 minutes).
2. Check that the operating environment such as ambient temperature and humidity is within the standard operating conditions (see *chapter 14*).
3. Apply appropriate input signals corresponding to 0, 50, and 100% of the input range and calculate the errors from the readings.
If the error does not fall within the accuracy range of the specifications, contact your nearest YOKOGAWA dealer.

Note

For thermocouple inputs, you must measure the temperature of the input terminal and apply a voltage taking into account the reference junction temperature.

DC Voltage Measurement

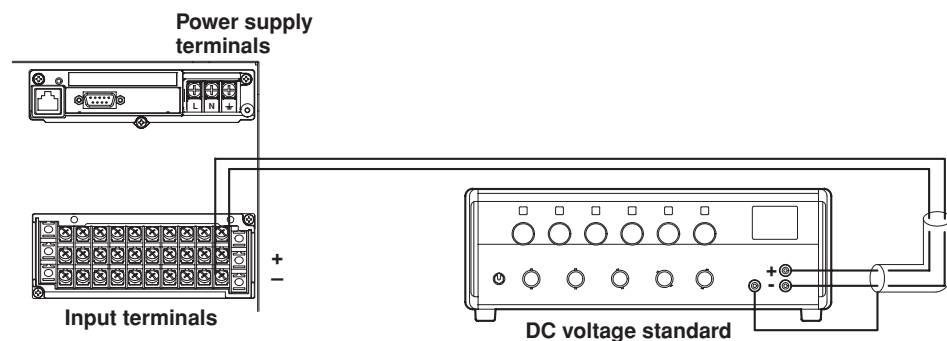

Temperature Measurement When Using an RTD

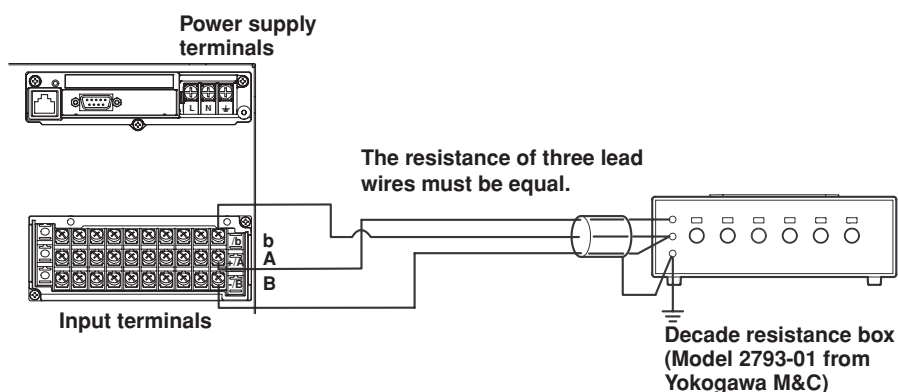

Temperature Measurement When Using a thermocouple

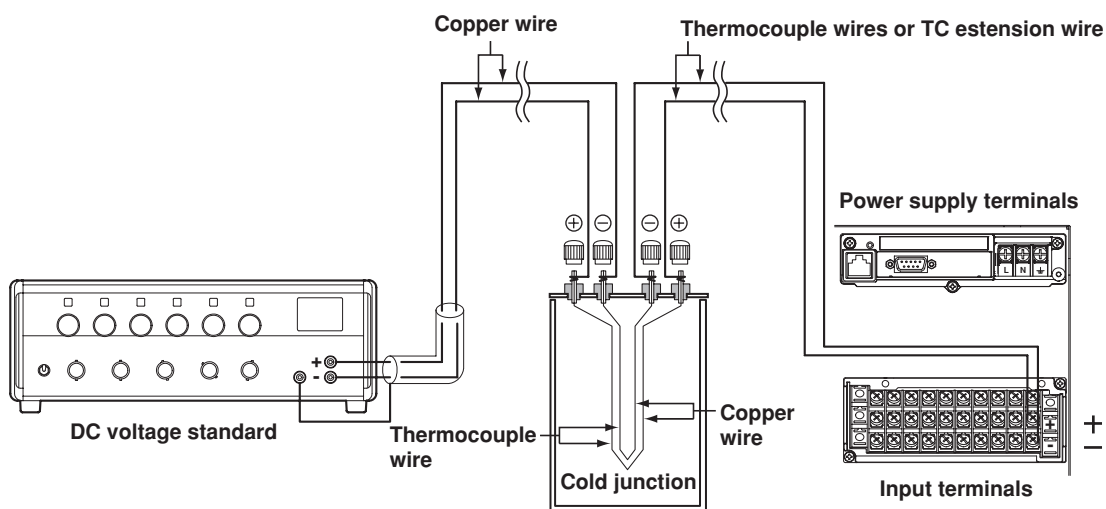

(0°C standard temperature device: Model ZC-114/ZA-10 from Coper Electronics Co., Ltd.)

Reference Junction Compensation of Thermocouple Input

As the measurement terminal of the CX2000 is generally at room temperature, the actual output of the thermocouple is different from the values given on the thermoelectromotive force table based on 0°C. The CX2000 performs compensation by measuring the temperature at the input terminal and adding the corresponding thermoelectromotive force to the actual output of the thermocouple. Therefore, when the measurement terminal is shorted (equivalent the detector tip being 0°C), the measured value indicates the temperature of the input terminal.

When calibrating the CX2000, this compensation voltage (thermoelectromotive force of 0 °C reference corresponding to the input terminal temperature) must be subtracted from the output of the standard generator before application. As shown in the figure, by using the 0 °C standard temperature device to compensate the reference junction at 0°C, you can input the thermoelectromotive force of 0°C reference from the DC voltage standard and perform the calibration.

13.3 Replacement of Parts

Recommended Replacement Period

To preserve the reliability of the CX2000 and to use the CX2000 in a good condition for an extended time, it is recommended that periodic replacements be made on parts. The replacement parts may change to accommodate preventive maintenance over extended time. Be sure to check with your nearest YOKOGAWA dealer.

The following table shows the recommended replacement period for expendable parts. The replacement period shown here applies when the CX2000 is used under standard operating conditions. For the actual replacement period, consider the actual conditions of use.

Replacements will be carried out by a YOKOGAWA engineer or an engineer certified by YOKOGAWA. When replacement is required, contact your nearest YOKOGAWA dealer.

Item	Replacement Period	Name	Specifications	Quantity Used
LCD	5 years	Backlight module		1
Battery	10 years	Lithium battery		1
Rubber strip	5 years	Dust and water proof rubber strip	Panel attachment section Operation cover	1 of each
Floppy disk drive	5 years			1
Zip drive	5 years			1
Relay	100,000 times	Control relay* ¹		2 per control output terminal block (for 2 loops)
PWB assembly	5 years	Power supply ASSY* ²		1
	5 years	Sub power supply ASSY* ²		1
	5 years	AD ASSY* ²		Depends on the specifications made at the time of purchase

*¹ Life time under rated load of relay contact. The replacement period varies depending on the load conditions and frequency of use.

*² Replacement Period at the Upper Limit of the Normal Operating Temperature (50°C)
The replacement period varies depending on the temperature in which the instrument is operated, and the instrument's specifications. If the instrument is used in a 30°C environment, it may be operational for 10 years or more.

Note

- The LCD replacement period indicates the half life of the brightness when the brightness is set to the factory default setting. The half life is shortened as the brightness is set higher. The deterioration of brightness varies depending on the condition of use, and its determination is subjective. Consider these facts for determining the actual replacement period.
- The color of the LCD may become yellowish as time elapses. The discoloration tends to progress faster as the brightness is set higher.

Replacement of the Terminal Block

Replacements of the terminal block will be carried out by a YOKOGAWA engineer or an engineer certified by YOKOGAWA. When replacement is required, contact your nearest YOKOGAWA dealer.

14.1 Input Section Specifications

Common to Control and Measurement

Thermocouple burnout:	Detection ON/OFF switchable (on each channel) Burnout up scale/down scale switchable
A/D integral time:	Select from 20 ms (50 Hz), 16.7 ms (60 Hz), 100 ms (50/60 Hz), and AUTO (automatically switches between 20 ms and 16.7 ms from the power supply frequency)

Control Input

Number of inputs:	Up to 10 inputs (depends on the model and control mode)
Period:	250, 500, 1000 ms (synchronized with the control period, 1000 ms when the A/D integral time is set to 100 ms)
Input type:	DCV (DC voltage), TC (thermocouple), RTD (resistance temperature detector), DCA (DC current, by adding an external shunt resistor)
Linear scaling:	Input ranges capable of scaling: TC, RTD, DCA
Available range of scaling:	–30000 to 30000 and the span within 30000
Decimal point position:	Can be set arbitrarily
Unit:	Can be set arbitrarily using up to 6 characters
Standard signal burnout:	For control input, burnout detection is possible not only on thermocouples but also standard signals.
PV input computation:	Input processing, square root computation (low cut 0.0 to 5.0%), ten-segment linearizer approximation, ten-segment linearizer bias, bias addition (in the measurement span of –100.0 to 100.0%), first-order lag computation (time constant from 1 to 120 s, off)
Auxiliary input computation:	Input processing, square root computation (low cut 0.0 to 5.0%), bias addition (in the measurement span of –100.0 to 100.0%), ratio computation (0.001 to 9.999), first-order lag computation (time constant from 1 to 120 s, off)
Input Range and Measurable Range:	

Input	Range	Measurable Range
DCV Only linear scaling allowed	20mV	–20.00 to 20.00mV
	60mV	–60.00 to 60.00mV
	200mV	–200.0 to 200.0mV
	2V	–2.000 to 2.000V
	6V	–6.000 to 6.000V
	20V	–20.00 to 20.00V
	50V	–50.00 to 50.00V
TC	R ¹	0.0 to 1760.0°C
	S ¹	0.0 to 1760.0°C
	B ¹	0.0 to 1820.0°C
	K ¹	–200.0 to 1370.0°C
	E ¹	–200.0 to 800.0°C
	J ¹	–200.0 to 1100.0°C
	T ¹	–200.0 to 400.0°C
	N ¹	0.0 to 1300.0°C
	W ²	0.0 to 2315.0°C
	L ³	–200.0 to 900.0°C
	U ³	–200.0 to 400.0°C
	PLATINEL	0.0 to 1400.0°C
	PR40-20	0.0 to 1900.0°C
	W3Re/W25Re	0.0 to 2400.0°C
	RTD ⁵	Pt100 ⁴
JPt100 ⁴		–200.0 to 550.0°C
Standard signal	1 to 5V	1.000 to 5.000V

¹: R, S, B, K, E, J, T, N: IEC584-1(1995), DIN IEC584, JIS C1602-1995

²: W: W-5% Re/W-26% Re(Hoskins Mfg. Co.), ASTM E988

³: L: Fe-CuNi, DIN43710, U: Cu-CuNi, DIN43710

⁴: Pt100: JIS C1604-1997, IEC751-1995, DIN IEC751-1996

JPt100: JIS C1604-1989, JIS C1606-1989

⁵: Measuring current: i = 1mA

14.1 Input Section Specifications

Measurement Input

Number of inputs: 10, 20 channels
 Scan interval: 1, 2 s (2 s when the A/D integral time is set to 100 ms)
 Input type: DCV (DC voltage), TC (thermocouple), RTD (resistance temperature detector), DI (operation log), DCA (DC current, by adding an external shunt resistor)

Input range and measurable range:

Input	Range	Measurable Range
DCV	20mV	-20.00 to 20.00mV
	60mV	-60.00 to 60.00mV
	200mV	-200.0 to 200.0mV
	2V	-2.000 to 2.000V
	6V	-6.000 to 6.000V
	20V	-20.00 to 20.00V
	50V	-50.00 to 50.00V
TC	R ^{*1}	0.0 to 1760.0°C
	S ^{*1}	0.0 to 1760.0°C
	B ^{*1}	0.0 to 1820.0°C
	K ^{*1}	-200.0 to 1370.0°C
	E ^{*1}	-200.0 to 800.0°C
	J ^{*1}	-200.0 to 1100.0°C
	T ^{*1}	-200.0 to 400.0°C
	N ^{*1}	0.0 to 1300.0°C
	W ^{*2}	0.0 to 2315.0°C
	L ^{*3}	-200.0 to 900.0°C
	U ^{*3}	-200.0 to 400.0°C
	PLATINEL	0.0 to 1400.0°C
	PR40-20	0.0 to 1900.0°C
W3Re/W25Re	0.0 to 2400.0°C	
RTD ^{*5}	Pt100 ^{*4}	-200.0 to 600.0°C
	JPt100 ^{*4}	-200.0 to 550.0°C
DI	DCV input	OFF: 2.4V or less ON: 2.4V or more
	Contact input	Contact ON/OFF

*1: R, S, B, K, E, J, T, N: IEC584-1(1995), DIN IEC584, JIS C1602-1995

*2: W: W-5% Re/W-26% Re(Hoskins Mfg. Co.), ASTM E988

*3: L: Fe-CuNi, DIN43710, U: Cu-CuNi, DIN43710

*4: Pt100: JIS C1604-1997, IEC751-1995, DIN IEC751-1996

JPt100: JIS C1604-1989, JIS C1606-1989

*5: Measuring current: i = 1mA

Filter function: Moving average ON/OFF switchable (selectable on each channel), set the moving average count from 2 to 16.

Computation: Difference computation: Computes the difference between two arbitrary channels

Computable range: DCV, TC, RTD

Linear scaling: Input ranges capable
 of scaling: DCV, TC, RTD
 Available range of scaling: -30000 to 30000
 Decimal place: Can be set arbitrarily
 Unit symbol: Can be set arbitrarily (up to 6 characters)

Square root scaling: Input ranges capable
 of scaling: DCV
 Available range of scaling: -30000 to 30000
 Decimal place: Can be set arbitrarily
 Unit symbol: Can be set arbitrarily (up to 6 characters)

14.2 Control Function

General Control Functions

Control Mode

Select from three controls for every two loops: single loop control, cascade control, and loop control with PV switching (however, only single loop control is possible on loops 5 and 6).

Control Computation Function

Continuous PID control, on/off control, time proportional PID control

PID control:

PID control mode	Operation mode	Operation Status	PID Control Method	Control Output Bump
Standard PID control mode	Fixed-point control operation	Local and not the secondary side of a cascade connection	PV derivative type PID	Yes
		Remote or secondary side of a cascade connection	Deviation derivative type PID	Yes
	Program control operation	Local and not the secondary side of a cascade connection or hold or soak	PV derivative type PID	Yes
		During program control (excluding hold and soak) or the secondary side of a cascade connection	Deviation derivative type PID	Yes
Fixed-point control mode	Fixed-point control operation	Local and not the secondary side of a cascade connection	PV derivative type PID	No
		Remote or secondary side of a cascade connection	PV derivative type PID	Yes
	Program control operation	Local and not the secondary side of a cascade connection or hold or soak	PV derivative type PID	No
		During program control (excluding hold and soak) or the secondary side of a cascade connection	PV derivative type PID	Yes

* The secondary side of a cascade connection refers to the secondary loop of which the cascade control mode is set to Cascade (of the Auto, Manual, and Cascade selections).

PID parameters: 8 sets/loop

Zone PID switch point: Up to 6

Super function (overshooting suppression): Available

Tracking function: SP tracking
PV tracking

Anti-reset windup (over-integration prevention)

Control period: 250, 500, 1000 ms

Operation Mode Switching

Remote, local, and program switching

Manual, auto, and cascade switching

Run/stop switching

Stop: Outputs the preset output

Auto tuning enable/disable switching

Principle: Limit cycle method

Selectable Range of Control Parameters

Proportional band: 0.1 to 999.9%

Integral time: 0 to 6,000 s

Derivative time: 0 to 6,000 s

On/Off control hysteresis width:

0.0 to 100.0% of the measurement span

Preset output: -5.0 to 105.0% of the control output (output when control computation is stopped, when PV input is burned out, and when measurement input is erroneous)

Selectable range of high/low limit of the output limiter:

-5.0 to 105.0% of measurement span

Shutdown function: Output up to 0 mA of control output during manual operation at 4 to 20 mA output (shutdown at less than or equal to -5.1%)

Output Velocity Limiter: Off or 0.1 to 100.0%/s

PV/SP Computation Function

Equations for each PV and SP can be set.

Computation type:	General purpose computation: Arithmetical operations (+, -, *, /), square root, absolute value, common logarithm, exponents, power, relational operations (<, ≤, >, ≥, =, ≠), and logical operators (AND, OR, NOT, XOR). Within group statistics: Average, max, (CLOG), min, integral values of data within groups Conditional expressions: [eq1?eq2: eq3]
Allowed data:	Measured data, measurement computation data, internal/external control data, communication input data, constants (W01-W36), control input channel data, control output module/expansion module DIO, measurement remote input, internal switches
Constants:	Up to 36 constants can be set
Error processing:	OVER: Use the upper limit value of the PV range for the PV and SP value. UNDER: Use the lower limit value of the PV range for the PV and SP value.

Logic Computation Function

Computation type:	Relational operations (<, ≤, >, ≥, =, ≠), and logical operators (AND, OR, NOT, XOR), and conditional expressions [eq1?eq2:eq3].
Allowed data:	Same as PV/SP computation function
Internal Switches	
Allowed number:	36 (SW001-SW36)
Fixed at “nonhold.”	

Analog Retransmission Function

Output format:	Current output (4-20 mA, 0-20 mA, 20-4 mA, 20-0A) Time proportional voltage pulse output, time proportional relay output
Display/recording:	Displayed as the OUT value, recorded to data file With loops set in analog retransmission, the PID computation is not performed.
Computation type:	Same as PV/SP computation function
Allowed data:	Same as PV/SP computation function

14.3 Alarm Function

Control Alarms

Control alarm types:	PV upper-limit, PV lower-limit, deviation high limit, deviation low limit, deviation high/low limit, deviation high and low limits, SP high limit, SP low limit, output high limit, and output low limit.
Other alarm types:	Self diagnosis alarm and FAIL alarm
Alarm stand-by action:	Turns off PV/SP alarms until operation becomes stable after starting control.
Alarm output:	6 outputs/2 loop (4 transistor outputs and 2 relay outputs)
Number of set alarms:	4 type/loop
Hysteresis:	Specifiable for each set alarm
Indication:	Status indication (alarm type) in the digital display section and common alarm indication when an alarm occurs. Hold/Non-hold switchable

Measurement Alarms

Alarm types:	High limit, low limit, difference high limit, difference low limit, high limit on rate-of-change, low limit on rate-of-change, delay high limit, and delay low limit (alarm delay)
Alarm delay time:	1 to 3600 s (1 hour)
Time interval for rate-of-change alarm:	Scan interval × 1 to 15
Alarm output:	6 outputs (option) * Can also be assigned to control output Energized/de-energized, hold/non-hold switchable
Number of settings:	Set up to 4 alarm on each channel
Hysteresis:	ON (0.5% of span)/OFF (all channels and levels common) switchable
Indication:	Status indication (alarm type) in the digital display section and common alarm indication when an alarm occurs. Hold/Non-hold switchable

14.4 Display Function

Displays

Displayed unit: 10.4-inch TFT color LCD (640 × 480 dots)
 Display color: Trend/bar graph display: Selectable from 12 colors
 Background: White or black selectable

Control group display: Number of displayed loops: Up to 6
 Number of displays: 8 displays (8 groups)
 Display styles: controller style, faceplate style, and hybrid style

Tuning display: Up to 21 types of parameters can be assigned

Trend display: Direction: Vertical or horizontal
 Number of displayed channels: Up to 10 channels per display (1 group)
 All channel trend display: Up to 116 channels
 Number of displays: 10 displays (10 groups)
 Thickness: Selectable from 1, 2, and 3 dots
 Update rate: Selectable from 1, 2, 5, 10, 20, 30 minutes, 1, 2, 4, 10 hours/division

Program operation status display:
 Displays the program operation status and the current PV simultaneously
 Number of displayed loops: Up to 6
 Number of displays: 1 display (1 group)
 Display update rate: Digital display section: 1 s
 Program display section: Follows the trend update rate.

Number of displayed channels:

Input type	Number of Control Loops (Maximum)	Display CH (Maximum)
Internal loop	6	18 (6 loops of PV, SP, and OUT)
Green series communications (option)	16	48 (16 loops of PV, SP, and OUT)
Measurement CH	–	10, 20
Computation channel (option)	–	30

Bar graph display: Direction: Vertical or horizontal
 Number of displayed channels: Up to 10 channels per display (1 group)
 Number of displays: 10 displays (10 groups)
 Scale: Selectable from 4 to 12
 Reference position: End or center
 Update rate: 1 s

Digital Display: Number of displayed channels: Up to 10 channels per display (1 group)
 Number of displays: 10 displays (10 groups)
 Update rate: 1 s

Overview display: Number of loops: Control: Up to 22 loops
 Number of channels: Measurement: Up to 50 CH (including computation CH)
 Measured values and alarm statuses of all channels

Information display:	Jumps to the trend display of the section specified by the cursor
	Alarm summary display: Log of alarms
	Event summary display: Summary of the program event status
	Control operation summary display: Summary of the control operation condition
	Message summary display: Time and content of the message
	Memory summary display: Files in the internal memory
Tag display:	Number of characters displayable: Up to 16 characters (measurement channels)
	Up to 8 characters (control loop tags)
	Up to 8 characters (control tag comments)
	Characters displayable: Alphanumeric characters
Other displayed information:	Memory status, scale value (0, 100%, display ON/OFF switchable), scale (up to 10 scales), grid (selectable from 4 to 12 divisions) as well as hour:min, time (year/month/day, hour:minute:second), trip line (thickness selectable from 1, 2, and 3 dots), message (up to 16 characters, up to 8 types), and alarm marks
Data browse function:	Displays data
	Display format: 2 divisions or full display
	Time axis operation: Reduce/expand and scroll the display
Automatic display switching function:	Interval: 5, 10, 20, 30 s, and 1 minute
LCD backlight saver function:	Time setting: 1, 2, 5, 10, 20, and 60 minutes

14.5 Storage Function

External storage medium: Select from the following when ordering

- 3.5-inch floppy disk (2HD)
- PCMCIA ATA flash memory card (4 to 440 MB)
- Zip disk (100 MB or 250 MB)

Storage Function

Stores internal control loop data (PV/SP/OUT of internal loops), external control loop data (PV/SP/OUT of externally connected controllers), measured data, and computed data

Internal control CH (PV/SP/OUT of each loop): 101 to 118 CH

External control CH (PV/SP/OUT of each loop): 201 to 248 CH

Stores 66 CH above, 20 measurement CH, and 30 computation CH as a data file

Storage data type:

Data Type	Recorded Items (CH, Loop, and System)	Data Content
Display data	Measurement, computation, internal control, external control	Min/Max in the timeup period
Event data	Measurement, computation, internal control, external control	Measured value per sampling interval
TLOG data	Measurement, computation	TLOG data value at TLOG timeup
Report data	Measurement, computation	CH value in units of hours/days/weeks/months
Manual sampled data	Measurement, computation, internal control, external control	ASCII format data at key/remote input
Alarm summary data	Measurement, computation, internal control, external control	Alarm occurrence/release information of the target CH
Event summary data	Event occurrence against the system	Time/PV event occurrence and release
Control mode summary data	System (program operation). For others, every internal loop/controller loop	Run/stop, local/remote, manual/auto/cascade switching Program hold/release, wait/release

Data save method: Manual save: Saves data when the external storage medium is inserted

Auto save: Saves data through key operation during continuous measurement

Save interval: 10 minutes to 31 days (during free trigger)
Saves at the end of sampling (when trigger is specified)

Sampling Interval:

Display data file: Synchronized to the waveform update rate

Event data file: Specify the sampling interval

Event data file sampling interval: Selectable from 1 and 2 s

Measurement data file:

Event data file: Saves the instantaneous values at the specified sampling interval

Display data file: Saves the maximum and minimum values within the display update rate

Combinations of files created

Event data file (trigger only) + display data file

Display data file only

Event data file only

Data format:

Binary format

Data per channel:

Display data:

Control data: 4 bytes/data point

Measurement data: 4 bytes/data point

Computation data: 8 bytes/data point

Event data:

Control data: 2 bytes/data point

Measurement data: 2 bytes/data point

Computation data: 4 bytes/data point

Sample length:

Per floppy disk during manual save

Display data file only:

When the number of control loops is 2; the number of measurement CH is 10; the number of computation CH is 8; and display update rate is 30 min./div (data save interval is 60 s)

Number of data points per CH = $1,200,000 \text{ bytes} / (6 \times 4 \text{ bytes} + 10 \times 4 \text{ bytes} + 8 \times 8 \text{ bytes}) = \text{Approx. } 9,375 \text{ data points}^*$

* Maximum number of data points is 100,000.

Sampling length per file = $9,375 \times 60 \text{ s} = 562,500 \text{ s} = \text{Approx. } 6 \text{ days}$

Event data file only:

When the number of control loops is 2; the number of measurement CH is 10; the number of computation CH is 8; and display update rate is 1 s

Number of data points per CH = $1,200,000 \text{ bytes} / (6 \times 2 \text{ bytes} + 10 \times 2 \text{ bytes} + 8 \times 4 \text{ bytes}) = \text{Approx. } 18,750 \text{ data points}^*$

* Maximum number of data points is 120,000.

Sampling length per file = $18,750 \times 1 \text{ s} = 18,750 \text{ s} = \text{Approx. } 5 \text{ hours}$

Display data file + event data file

Display data file size = 900,000 bytes

Up to 75,000 data points

Event data file size = 300,000 bytes

Up to 30,000 data points

When using a Zip drive or an ATA memory card, the file size varies depending on the storage capacity of the medium.

Sample length example:

Number of control loops: 6 loops, measurement channels: 10 channels
computation channel: 0 channels

Display data file only

Display update rate (min/div)	1 min	5 min	20 min	30 min	60 min	240 min
Save interval (s)	2 s	10 s	40 s	60 s	120 s	480 s
Sample length	Approx. 5 h	Approx. 28 h	Approx. 5 days	Approx. 7 days	Approx. 14 days	Approx. 56 days

Event data file only

Save interval	1 s	5 s	30 s	120 s
Sample length	Approx. 5 h	Approx. 29 h	Approx. 7 days	Approx. 29 days

Display data file + event data file

Display data file

Display update rate (min/div)	1 min	5 min	20 min	30 min	60 min	240 min
Save interval (s)	2 s	10 s	40 s	60 s	120 s	480 s
Sample length	Approx. 4 h	Approx. 21 h	Approx. 85 h	Approx. 5 days	Approx. 11 days	Approx. 42 days

Event data file only

Save interval	1 s	5 s	30 s	120 s
Sample length	Approx. 1 h	Approx. 7 h	Approx. 40 h	Approx. 7 days

14.5 Storage Function

Number of control loops: 10 loops, measurement channels: 10 channels
 computation channel: 0 channels

Display data file only

Display update rate (min/div)	1 min	5 min	20 min	30 min	60 min	240 min
Save interval (s)	2 s	10 s	40 s	60 s	120 s	480 s
Sample length	Approx. 4 h	Approx. 20 h	Approx. 3 days	Approx. 5 days	Approx. 10 days	Approx. 40 days

Event data file only

Save interval	1 s	5 s	30 s	120 s
Sample length	Approx. 4 h	Approx. 20 h	Approx. 5 days	Approx. 20 days

Display data file + event data file

Display data file

Display update rate (min/div)	1 min	5 min	20 min	30 min	60 min	240 min
Save interval (s)	2 s	10 s	40 s	60 s	120 s	480 s
Sample length	Approx. 3 h	Approx. 15 h	Approx. 2 days	Approx. 3 days	Approx. 7 days	Approx. 30 days

Event data file only

Save interval	1 s	5 s	30 s	120 s
Sample length	Approx. 1 h	Approx. 5 h	Approx. 29 h	Approx. 5 days

Manual sampled data: Trigger: Key operation, communication command, or remote input
 Data format: ASCII
 Maximum number of data sets that the internal memory can hold: 50

TLOG data (only on models with the computation function):

Trigger: Timeout of the timer

Data format: Binary

Maximum number of data sets that the internal memory can hold: 400 (or within 16 files)

Report data (only on models with the computation function):

Type: Hourly, daily, hourly + daily, daily + weekly, daily + monthly

Data format: ASCII

Maximum number of data sets that the internal memory can hold: 40

Trigger function:

Event data file: Select the mode from FREE, TRIG, and ROTATE

Display data file + event data file: Select the mode from TRIG and ROTATE

Display copy function:

Copy method: Key operation, communication command, or remote input

Data format: PNG

Destination: External storage medium or communication output

14.6 Communication Functions

Ethernet Communications

Connection:	Ethernet (10BASE-T)
Protocol:	TCP/IP
E-mail transmission function:	Recipient addresses: 2 address groups (multiple addresses can be specified using up to 150 characters for each group) Notification types: Notifies the following information through e-mail. Select notify or not notify for each address group. Alarm notification, appointed hour notification, and report notification
Web server function:	Displays screen images, alarm information, instantaneous values, and other information on a browser application (Microsoft Internet Explorer 5.0)
FTP client function:	Automatically transfers data files from the CX2000 to a server
FTP server function:	File transfer and directory operation and file deletion on the external storage medium from a request by a PC on the network
Real-time monitor function:	Real-time monitoring of CX2000 measured/computed data is possible using a dedicated protocol

Serial Communications

Used for ladder communications, Green series communications, and Modbus communications

Connection:	EIA RS-232(CX2 □ □ □ 0-□-1-□) EIA RS-422/485(CX2 □ □ □ 0-□-2-□)
Protocol:	Dedicated protocol or Modbus protocol
Synchronization:	Start-stop synchronization
Transmission mode (RS-422/485):	Four-wire half-duplex multi-drop connection (1:N (N = 1 to 31))
Data rate:	1200, 2400, 4800, 9600, 19200, 38400 bps
Data length:	7 or 8 bits
Stop bit:	1 bit
Parity:	ODD, EVEN, and NONE
Communication distance (RS-422/485):	1.2 km
Communication mode:	Input/output of control and settings: ASCII mode Measured data output: ASCII/binary mode
Modbus communications:	Operation mode: RTU MASTER or RTU SLAVE RTU MASTER: Used for Green series communications Up to 16 loops can be connected RTU SLAVE: Outputs measured/computed data, alarm status, etc.
Ladder communications:	Data input/output using BCD codes Ladder communication module of the FA-M3 programmable controller by YOKOGAWA, communication protocol with program controllers made by other manufacturers

14.6 Communication Functions

Green series communications:

Function for communicating with UT Series Controllers (UT3□0, UT4□0, UT5□0, and UT750) by Yokogawa M&C Corporation and other controllers (UT Green series controllers with single-loop heating/cooling control, UT750 and UP Series controllers with custom computation and controllers by other manufacturers).

14.7 Options

Program Setup Function (/PG1 and /PG2)

Program Setup Function

Number of program patterns:

4(/PG1) and 30(/PG2)

Number of segments per program pattern:

Up to 99

Number of program segments:

Up to 300 (total of all program patterns)

Number of program events:

Up to 800

Program repeat count: Up to 999 or unlimited

Segment time: 0 min 1 s to 99 h 59 min 50 s

Program pattern start/stop:

Start, stop, hold, and advance the program pattern through contact input or instrument operation

Program pattern switching:

Switch using contact input or instrument operation

Wait function:

Wait time: Off, 0 min 1 s to 99 min 59 s

Wait zone: 0 to 100% of the measurement input span

PID Parameter Switching

Segment PID switching: Can specify the PID parameter number to be used for each segment.

Zone PID switching: PID parameter switchable through the PV input value

Time Events

Output the progress status of the program pattern using contact output

Number of setpoints: Up to 16 points per segment

Output: After a given time elapses after switching segments

Elapsed time: 0 to 99 h 59 min 59 s

PV Events

PV and deviation alarm function within the program pattern

Number of setpoints: Up to 16 points.

Type:

PV high limit, PV low limit, deviation high limit, deviation low limit, deviation high/low limit, deviation high and low limits, SP high limit, SP low limit, output high limit, and output low limit.

Control Mode Switching

Program RESET/Program RUN switching

Run/stop status of the program operation

HOLD/HOLD release:

HOLD/release HOLD the progress of the program operation when program is running

Measurement alarm (/A6, /A6R, /A4F, /A4FR)

- Number of outputs: 6 outputs (/A6, /A6R, /A4F, /A4FR)
- Number of inputs: 8 inputs (/A6R, A4FR)
- Relay contact capacity: 250 VDC/0.1 A (resistive load)
250 VAC (50/60 Hz)/3A
- Output type: NO-C-NC (energized/de-energized, AND/OR, and hold and non-hold switchable)
- Remote control: (/A6R, A4FR)
 - The following control is possible using contact inputs (up to 8 points can be specified)
 - Memory start/stop (level)
 - Event data file using external trigger input (trigger, 250 ms or more)
 - Time adjustment (adjust the time to on the hour using contact input, trigger, 250 ms or more)
 - Computation start/stop (level)
 - Computed data reset (trigger, 250 ms or more)
 - Manual sample (trigger, 250 ms or more)
 - Message write operation (set up to 8 points, trigger, 250 ms or more)
 - Load settings (up to 3 points, trigger, 250 ms or more)
 - Alarm ACK (trigger, 250 ms or more)
 - Snapshot (trigger, 250 ms or more)

- FAIL/memory end output (/A4F option or /A4FR option)
 - Outputs relay contact signals when system errors occur, at the specified time before overwriting of the internal memory is to start, and based on the remaining free space on the external storage medium.
 - Manual save mode:
 - Outputs relay contact signals the specified time before overwriting starts (select from 1, 2, 5, 10, 20, 50, and 100 hours)
 - Auto save mode:
 - Outputs relay contact signals when the remaining free space on the external storage medium falls to 10%.

Control DIO expansion (/CST1)

- I/O Specifications
- Contact input
 - Number of inputs: 12
 - Input signal: Non-voltage contact or open collector (TTL or transistor)
 - Input condition: ON voltage: 0.5 V or less (30 mADC)
Leakage current when turned OFF: 0.25 mA or less
 - Input format: Photocoupler isolation (4 points common)
 - Withstand voltage: 500 VDC for 1 minute (between the input terminal and earth)
- Contact output
 - Transistor output: 12 outputs
 - Transistor contact rating: 24 VDC, 50 mA

VGA Output (/D5)

- Connection to an external display monitor possible
- Resolution: 640 × 480 dots (VGA specifications)
- Connector: D-SUB mini 15 pins

Computation Function (/M1)

Can perform the following computations, display the trend or numerical values of the computed data, and store computed data.

Number of computation channels: 30 channels

Computation types: General arithmetic operations: Four arithmetic operations, square root, absolute, common logarithm, exponential, power, relational operations (<, ≤, >, ≥, =, ≠), logical operations (AND, OR, NOT, XOR)

 Statistical computation: Average, maximum, minimum, and sum of time series data

 Rolling average: Performs rolling average on the computed results

Constant: Set up to 30 constants

Digital input via communications: Can be used in equations other than statistical computation.

 Number of values: 30

Remote input: Use remote input status (0/1) equations

 Number of inputs: 8

Control contact input: Use contact input status (0/1) equations

 Number of inputs: 6 (DI001 to DI006), 6 (DI101 to DI106), 6 (DI201 to DI206), 12 (RI001 to RI012)

Report function: Report type: Hourly, daily, hourly + daily, daily + weekly, daily + monthly

 Computation type: Average, maximum, minimum, and sum

 Data format: ASCII format

3 terminal isolated RTD Input (/N2)

A, B, and b terminals of the RTD are of isolated input type (for measurement inputs).

24 VDC/AC power supply driven (/P1)

Rated supply voltage: 24 VDC/AC

Supply voltage range used: 21.6 to 26.4 VDC

Withstand voltage: Between the power terminal and earth: 500 VAC

Power consumption:

Supply Voltage	LCD Saver Mode	Normal	Max.
24 VDC	Approx. 25 VA	Approx. 26 VA	41 VA
24 VAC (50/60 Hz)	Approx. 39 VA	Approx. 40 VA	60 VA

24 VDC power supply for transmitter (/TPS4 option)

Output voltage: 22.8 to 25.2 VDC (under rated load current)

Rated output current: 4 to 20 mADC

Maximum output current: 25 mADC (overcurrent suppression operation current: approx. 68 mADC)

Allowable cable resistance: $RL \leq (17.8 - \text{minimum operation voltage of transmitter})/0.02 \text{ A}$ (load shut resistor 250 Ω and not including the drop voltage)

Maximum length of cable: 2 km (when using the CEV cable)

Insulation resistance: Between output and earth: 20 M Ω (500 VDC)

Withstand voltage: Between output and earth: 500 VAC (50/60 Hz, $i = 10\text{mA}$) for one minute

Between output terminals: 500 VAC (50/60 Hz, $I = 10\text{mA}$) for one minute

Batch Header (/BT1):

- Information added to the measured/control/computed data:
 - Serial number of the CX, Application name, Supervisor name, Manager name, Batch number, Lot number, Comment information
- Displaying information: Displays the application name, supervisor name, manager name, batch name, and comment when data acquisition to the internal memory is stopped.
- Identifying operators (users) by using the key login function:
 - User names that are already registered cannot be specified
 - the combinations of user IDs and passwords that are identical to those that have been registered by any user in the past cannot be specified.
- Messages: Messages 1 through 3 can be changed in the operation mode.
- Confirming the stored data:
 - Batch information can be shown on the memory information display.

14.8 General Specifications

Construction

Mounting angle:	Up to 30° of backward tilt angle allowed, no tilt to the left or right
Mounting panel thickness:	2 to 26 mm
Material:	Case: Steel plate Bezel: Polycarbonate
Color:	Case: Pale cobalt blue (DIC16-102 or equivalent) Bezel: Charcoal gray light (Munsell 10B3.6/0.3 or equivalent)
Front panel:	Water and dust-proof (based on IEC529-IP65, and NEMA No.250 TYPE 4 (except external icing test))
External dimensions:	288(W) × 288(H) × 220(D) mm
Weight (approx.):	CX2010: 6.6 kg, CX2020: 7.0 kg, CX2210: 6.9 kg, CX2220: 7.2 kg, CX2410: 7.1 kg, CX2420: 7.5 kg, CX2610: 7.4 kg, CX2620: 7.7 kg

I/O Specifications

Control Output

Current output:	Number of outputs: 2 outputs/2 loops Output signal: 4 to 20 mADC or 0 to 20 mADC Load resistance: 600 Ω or less Output accuracy: ±0.1% of span (1 mA or more) Temperature drift: ±200 ppm/° C (output section)
Voltage pulse output:	Number of outputs: 2 outputs/2 loops Output signal: ON voltage = 12 VDC Load resistance: 600 Ω or more Resolution: 0.1%
Relay contact output:	Number of outputs: 2 outputs/2 loops Output signal: NC, NO, COM Contact rating: 250 VAC, 3 A or 30 VDC, 3 A (resistive load)

Contact Input

Number of inputs:	6 inputs/2 loops
Input signal:	Non-voltage contact or open collector (TTL or transistor)
Input condition:	ON voltage: 0.5 V or less (30 mADC) Leakage current when turned OFF: 0.25 mA or less
Input format:	Photocoupler isolation (2 points common)

Contact output

Relay output:	2 outputs/2 loops
Relay contact rating:	250 VAC, 1 A or 30 VDC, 1 A (resistive load)
Transistor output:	4 outputs/2 loops Transistor contact rating: 24 VDC, 50 mA

Analog Input Section

Control PV input:	Up to 10 inputs (isolated) (the number of inputs varies depending on the model and control mode) Period: 250, 500, 1000 ms
Measurement input:	10 or 20 inputs (DCV, TC, and ID are isolated) Period: 1 s or 2 s

Standard Installation Environment

Standard operating conditions:

- Ambient temperature: 0 to 50 °C (5 to 40 °C when floppy disk or Zip disk is in operation)
- Ambient humidity: 20 to 80% RH (at 5 to 40 °C)
- Vibration: 10 to 60 Hz 0.2 m/s²
- Shock: Not allowed
- Magnetic field: 400 A/m or less (DC and 50/60 Hz)
- External noise: Normal mode (50/60 Hz)
 - Volt: The peak value including the signal must be less than 1.2 times the measuring range.
 - TC: The peak value including the signal must be less than 1.2 times the measuring thermal electromotive force.
 - RTD: 50 mV or less
- Common mode noise (50/60 Hz): 250 Vrms AC or less for all ranges
- Maximum noise voltage between channels (50/60 Hz): 250 Vrms AC or less
- Mounting position: Up to 30° of backward tilt angle allowed, no tilt to the left or right
- Warm-up time: At least 30 minutes after power-up
- Altitude: 2000 m or less

Transport and storage conditions:

- Ambient temperature: -25 to 60 °C
- Humidity: 5 to 95%RH (no condensation)
- Vibration: 10 to 60 Hz 4.9 m/s²
- Shock: 392 m/s² or less (packaged condition)

Safety and EMC Standards

- CSA: Certified by CSA22.2 No. 1010.1, Installation category (Overvoltage category) II^{*1}, Pollution degree 2^{*2}
- UL: Gertified by UL61010B-B (CSA NRTL/C)
- CE: EMC: Complies with EN61326-1
 - Complies with EN61000-3-2
 - Complies with EN61000-3-3
- Low voltage: Complies with EN61010-1, Measurement category II^{*3}

^{*1} "Installation category (Overvoltage category)" describes a number which defines a transient overvoltage condition. It implies the regulation for impulse withstand voltage. "II" applies to electrical equipment which is supplied from the fixed installation like distribution board.

^{*2} "Pollution degree" describes the degree to which a solid, liquid, or gas which deteriorates dielectric strength or surface resistivity is adhering. "2" applies to normal indoor atmosphere. Normally, only non-conductive pollution occurs.

^{*3} Applies to measuring circuits connected to low voltage installation, and electrical instruments supplied with power from fixed equipment such as electric switchboards.

EMC standards: Complies with EN61326-1.

Power Supply

- Supply voltage: 100 to 110 VAC±10%, 200 to 220 VAC±10%
- Power frequency: 50 Hz ± 2%, 60 Hz ± 2%

Power consumption:

Supply Voltage	LCD Saver Mode	Normal	Max.
100 VAC	Approx. 43 VA	Approx. 45 VA	75 VA
240 VAC	Approx. 62 VA	Approx. 65 VA	106 VA

* For the power supply specifications when the CX1000 is driven by the 24-V power supply, see "24 VDC/AC power supply driven (/P1)" in section 14.7, "Options."

Isolation

Insulation resistance: Between each terminal and earth: 20 MΩ or more (at 500 VDC)
 Withstand voltage: Between the power terminal and earth:
 1500 VAC at 50/60 Hz for one minute
 Between the contact output terminal and earth:
 1500 VAC at 50/60 Hz for one minute
 Between the measurement input terminal and earth:
 1500 VAC at 50/60 Hz for one minute
 Mutually between measurement input terminals:
 1000 VAC at 50/60 Hz for one minute
 Between the contact input terminal and earth:
 500 VDC for one minute
 Between the current output terminal and earth:
 500 VAC at 50/60 Hz for one minute
 Between the voltage pulse output terminal and earth:
 500 VAC at 50/60 Hz for one minute
 Between the transistor contact output and earth:
 500 VDC for one minute
 Grounding resistance: 100 Ω or less

Standard Performance

Measurement accuracy: The following specifications apply to operation of the CX2000 under standard operation conditions:
 Temperature: 23 ± 2 °C
 Humidity: 55% ± 10% RH
 Supply voltage: 90 to 132 or 180 to 250 VAC
 Power frequency: 50/60 Hz ± 1% Warm-up time: At least 30 minutes.
 Other ambient conditions such as vibration should not adversely affect the operation of the CX2000.

Input Type	Range	Measurement Accuracy (Digital Display)	Max. Resolution of Digital Display
DCV	20 mV	±(0.1% of rdg + 2digits)	10 μV
	60 mV		10 μV
	200 mV		100 μV
	2 V		1mV
	6 V		1mV
	20 V		10mV
	50 V		±(0.1% of rdg + 3digits)
TC (Excluding the reference junction compensation accuracy)	R	±(0.15% of rdg + 1°C) Except R, S: 0 to 100°C: ±3.7°C, 100.0 to 300°C: ±1.5B: 400 to 600°C: ±2°C, Accuracy at less than 400°C is not warranted.	0.1°C
	S		
	B		
	K	±(0.15% of rdg + 0.7°C) Except ±(0.15% of rdg + 1°C) at -200 to -100°C	
	E	±(0.15% of rdg + 0.5°C)	
	J	±(0.15% of rdg + 0.5°C)	
	T	Except ±(0.15% of rdg + 0.7°C) at -200 to -100°C	
	N	±(0.15% of rdg + 0.7°C)	
	W	±(0.15% of rdg + 1°C)	
	L	±(0.15% of rdg + 0.5°C)	
	U	Except ±(0.15% of rdg + 0.7°C at -200 to 100°C)	
	PLATINEL	±(0.25% of rdg ± 2.3°C)	
PR40-20	0 to 450°C	Accuracy not guaranteed	
	450 to 750°C	±(0.9% of rdg + 16.0°C)	
	750 to 1100°C	±(0.9% of rdg + 6.0°C)	
W3Re/W25Re	1100 to 1900°C ±(0.9% of rdg + 2.0°C)		
RTD	Pt100	±(0.15% of rdg + 0.3°C)	
	JPt100		

Measurement accuracy during scaling:

$$\text{Accuracy during scaling (digits)} = \text{measurement accuracy (digits)} \times \text{multiplier} + 2 \text{ digits (rounded up)}$$

* Fractions rounded up

Reference junction compensation:

INT (internal) and EXT (external) switchable (common to all channels)

14.8 General Specifications

Reference junction compensation accuracy:	Type R, S, B, W, PR40-20, W3Re/W25Re: ± 1.0 °C Type K, J, E, T, N, L, U PLATINEL: ± 0.5 °C (only when measuring 0 °C or above)
Maximum input voltage:	Voltage range less than or equal to 2 VDC and thermocouples: ± 10 VDC (continuous) 6 V and higher voltage ranges: ± 60 VDC (continuous)
Input resistance:	Voltage range less than or equal to 2 VDC and thermocouples: 10 M Ω or more 6 V and higher voltage ranges: Approx. 1 M Ω
Input source resistance:	Volt, TC: 2 k Ω or less RTD input: 10 Ω or less per wire (the resistance of all three wires must be equal).
Input bias current:	10 nA or less
Common mode rejection ratio:	120 dB (50/60 Hz $\pm 0.1\%$, 500 Ω unbalanced, between the minus terminal and ground)
Normal mode rejection ratio:	40 dB (50/60 Hz $\pm 0.1\%$)

Effects of Operating Conditions

Ambient temperature:	With temperature variation of 10° C: $\pm(0.1\%$ of rdg + 1 digit) or less for Volt and TC ranges * Excluding the error of reference junction compensation $\pm(0.1\%$ of rdg + 2 digits) or less for RTD ranges
Power supply fluctuation:	With variation within 90 to 132 V and 180 to 250 VAC (50/60 Hz): 1 digit or less With variation of ± 2 Hz from rated power frequency (at 100 VAC): $\pm(0.1\%$ of rdg + 1 digit) or less
Magnetic field:	AC (50/60 Hz) and DC 400 A/m fields: $\pm(0.1\%$ of rdg + 10 digits) or less
Input source resistance:	With variation of +1 k Ω : (1) Volt range Ranges of 2 VDC or less: Within ± 10 μ V Ranges of 6 VDC or greater: $\pm 0.1\%$ of rdg or less (2) TC range Within ± 10 μ V (± 100 μ V when burnout is specified) (3) RTD range (Pt100) With variation of 10 Ω per wire (when the resistance of all three wires are equal): $\pm(0.1\%$ of rdg + 1 digit) With maximum difference of 40 m Ω between wires: Approx. 0.1 ° C

Other Specifications

Clock:	With a calendar function
Daylight savings:	Can be enabled The time can be adjusted by a remote contact.
Accuracy of clock:	± 100 ppm, excluding the delay that occurs at power-up (1 s or less)
Keylock function:	Can be turned ON/OFF. Password can be specified.
Login function:	Log in by entering a user name, user ID, and password.

14.9 Dimensional Drawings

Unit: mm

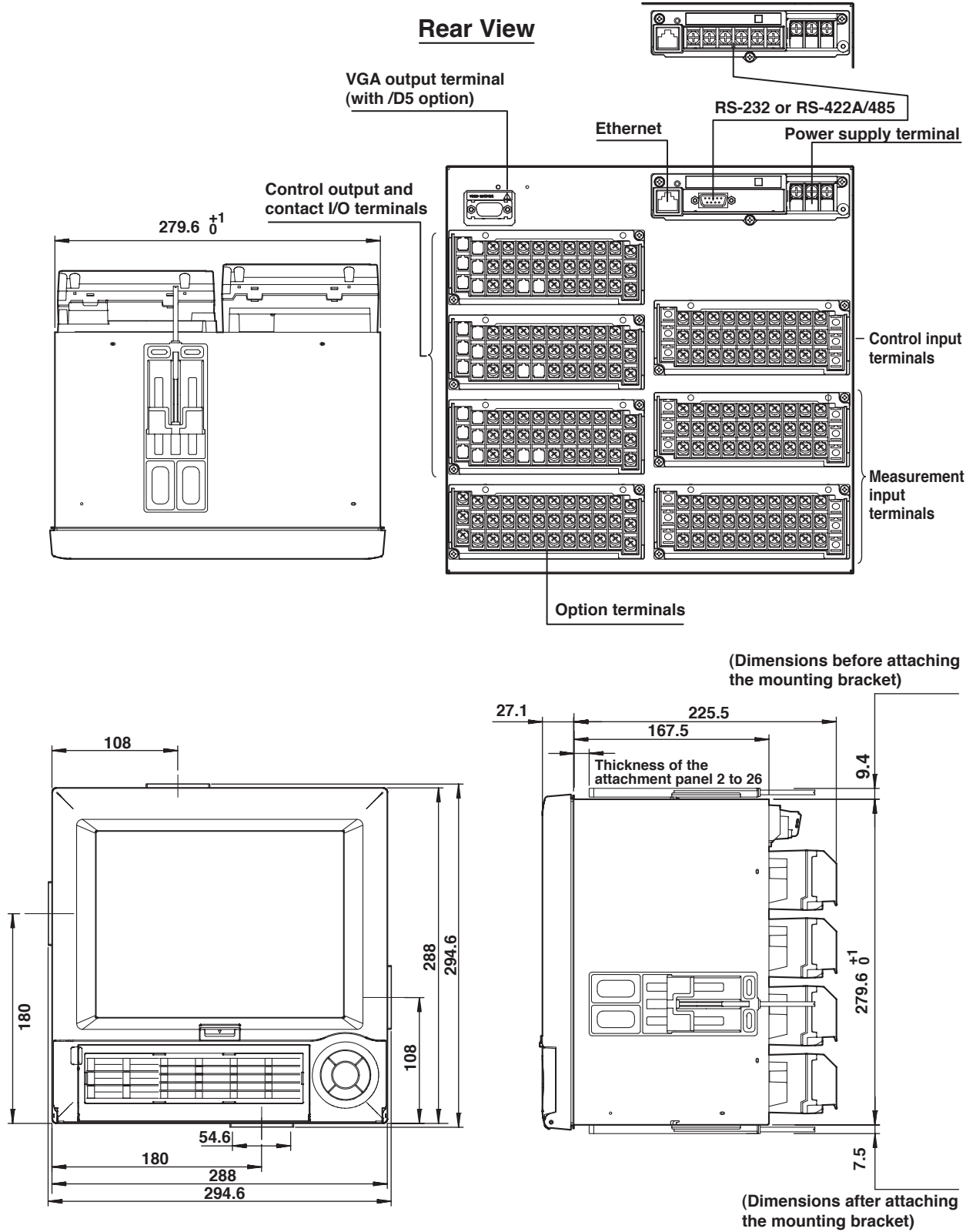

If not specified, the tolerance is $\pm 3\%$. However, in cases of less than 10 mm, the tolerance is ± 0.3 mm.

Appendix 1 Supplementary Explanation of the Acquisition of Display Data/Event Data to the Internal Memory

This section explains in detail the function of the acquisition of display data/event data to the internal memory. It is a supplement to the information covered in “Data Acquisition to the Internal Memory” in section 1.17, “Data Storage Function.”

Acquisition Mode of Event Data

Mode	Description
Free	Press the [START] key to start acquiring data to the internal memory; press the [STOP] key to stop the acquisition. Data is overwritten when the event data acquisition area is full or when the number of event data files* exceeds 16. * Number of event data files In manual save mode, a file is created for each data write operation (start and stop operations). In auto save mode, a file is created every specified time (data length) and at every specified date/time.

Trigger
When the acquisition area of the internal memory is not divided:
 A single event data file is created in the internal memory. When the [START] key is pressed, the CX2000 enters a trigger-wait state. After the trigger condition is met, a specified time (data length) of data is acquired, and acquisition is stopped. Beyond this point, no more data is acquired even if the trigger condition is met.

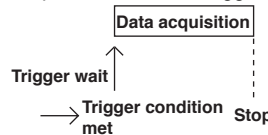

When the acquisition area of the internal memory is divided:
 A single event data file is created in each divided area (block). When the [START] key is pressed, the CX2000 enters a trigger-wait state. After the trigger condition is met, a specified time of data is acquired in a single block, and acquisition is stopped. The CX2000 enters the trigger-wait state. If the trigger condition is met again, data is acquired to the next block. When data is acquired to all blocks, no more data is acquired even if the trigger condition is met.

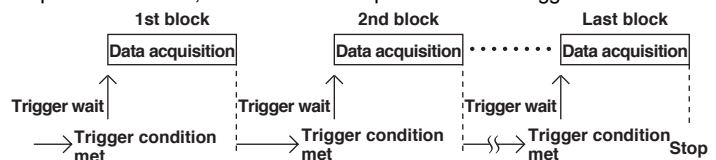

Rotate
When the acquisition area of the internal memory is not divided:
 A single event data file is created in the internal memory. When [START] is pressed, the CX2000 enters a trigger-wait state. After the trigger condition is met, a specified time data length of data is acquired, and acquisition is stopped. The CX2000 enters the trigger-wait state. If the trigger condition is met again, the data is overwritten. Overwriting of the data is repeated each time the trigger condition is met while the CX2000 is in the trigger-wait state. To stop the acquisition of the event data, press the [STOP] key.

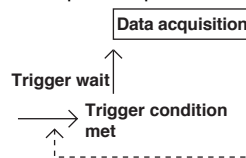

When the acquisition area of the internal memory is divided:
 A single event data file is created in each divided area (block). When the [START] key is pressed, the CX2000 enters a trigger-wait state. After the trigger condition is met, a specified time of data is acquired in a single block, and acquisition is stopped. The CX2000 enters the trigger-wait state. If the trigger condition is met again, data is acquired to the next block. If the trigger condition is met after data has been acquired to all blocks, the first block is overwritten.

Appendix 1 Supplementary Explanation of the Acquisition of Display Data/Event Data to the Internal Memory

Overwriting of the data to the next block is repeated each time the trigger condition is met while the CX2000 is in the trigger-wait state. To stop the acquisition of the event data, press the [STOP] key.

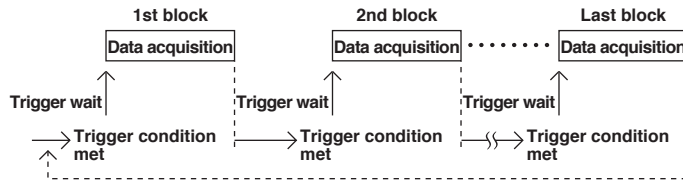

Note

- You can check the event data information in the internal memory using the memory summary.
- If a power failure occurs, the event data in the internal memory is closed as a single file.

Pre-trigger of Event Data

You can set the pre-trigger when the acquisition mode of event data is set to [Trigger] or [Rotate].

It is a function used to save the data before the point where the trigger condition is met as event data. This function is convenient when you wish to view the data before the occurrence of a certain event such as when an alarm occurs.

Specify the pre-trigger as a percentage (0, 5, 25, 50, 75, 95, or 100%) of the acquisition time of the event data. If set to 0%, the entire data is the data existing after the trigger condition is met. The initial value is 0%.

Trigger Type of Event Data

You can set the type when the acquisition mode of event data is set to [Trigger] or [Rotate]. You can select the type of trigger used to start the acquisition of the event data from the following. If you specify multiple trigger types, OR logic is applied to the triggers. Thus, if any of the trigger conditions are met, event data acquisition is started.

Type	Description
Key trigger	The trigger condition is satisfied when the FUNC > [Trigger] soft key or the USER key (only when the "trigger" function is assigned to the USER key) is pressed.
External trigger	If [Trigger] is assigned to the remote control terminal, the trigger condition is satisfied with a remote input.
Alarm trigger	The trigger condition is satisfied when any of the alarms occur.

Number of Data Points That Can Be Acquired to the Internal Memory and Sampling Length

This section describes the number of display data and event data points that can be acquired to the internal memory and the sampling length. The information can be used to estimate the time until the internal memory becomes full or used to determine the number of channels and sampling interval for saving the data.

For the auto save interval of display data and sampling length of event data, a selectable range of values are assigned to the soft keys and displayed based on the information described here.

Number of Bytes per Channel

Display data consists of minimum and maximum values for each sampling interval.

Event data consists of instantaneous values.

The number of data bytes per channel is shown in the following table.

Data Type	Measurement Channel	Computation Channel
Display data	4 bytes/channel	8 bytes/channel
Event data	2 bytes/channel	4 bytes/channel

Appendix 1 Supplementary Explanation of the Acquisition of Display Data/Event Data to the Internal Memory

Example: Data size when acquiring the data of channels 1 to 4 (measurement channels) and channel 31 (computation channel) to the internal memory.

Display data

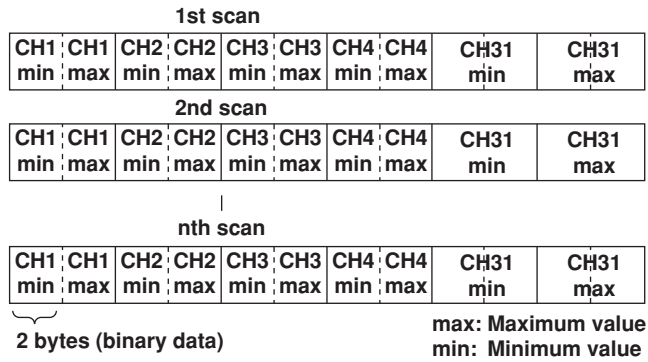

Event data

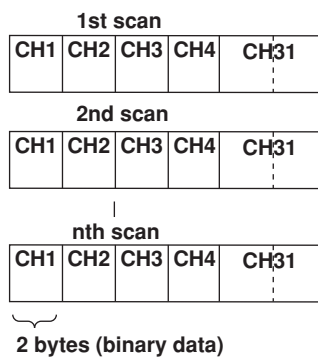

Internal Memory Size

The size of the internal memory used for data acquisition is 1.2 MB. Depending on the type of data to be acquired, the internal memory is allocated as follows.

Data Type	Internal Memory Size
Display data only	1.2 MB
Display data and event data	Display data: 0.9 MB Event data: 0.3 MB
Event data only	1.2 MB

Appendix 1 Supplementary Explanation of the Acquisition of Display Data/Event Data to the Internal Memory

Maximum Number of Data Points per Channel

When the type of data, the number of measurement channels, the number of computation channels, number of internal control channels, and the number of external control channels that are to be acquired to the internal memory are determined, the maximum number of times data can be acquired can be derived from the internal memory size. This number is referred to as the maximum number of data points per channel.

The maximum number of data points can be derived from the equations in the following table.

Data to Be Saved	Maximum Number of Data Points
Display data only	1,200,000 bytes/(number of measurement CH × 4 + number of computation CH × 8 + number of internal control CH × 4 + number of external control CH × 4) * The maximum number is 100,000.
Display data and event data	<ul style="list-style-type: none"> • Display data 900,000 bytes/(number of measurement CH × 4 + number of computation CH × 8 + number of internal control CH × 4 + number of external control CH × 4) * The maximum number is 75,000. • Event data 300,000 bytes/(number of measurement CH × 2 + number of computation CH × 4 + number of internal control CH × 4 + number of external control CH × 4) * The maximum number is 30,000.
Event data only	1,200,000 bytes/(number of measurement channels × 2 + number of computation channels × 4) * The maximum number is 120,000.

Maximum Sampling Length

The maximum sampling length can be determined from the time it takes to acquire the maximum number of data to the internal memory using the following equation.

Maximum sampling length = maximum number of data points × sampling interval

Calculation Example of Maximum Number of Data Points and Maximum Sampling Length

• Display Data Only

Measurement channel: 2, computation channel: none, internal control channel: none, external control channel: none.

Data	Maximum Number of Data Points and Maximum Sampling Length
Display data	Maximum number of data points = $1,200,000 / (2\text{CH} \times 4 \text{ bytes} + 0 \times 8 \text{ bytes} + 0 \times 4 \text{ bytes} + 0 \times 4 \text{ bytes}) = 150,000$ However, the maximum is limited to 100,000 data points. Therefore, the maximum number of data points = 100,000 . When the display update rate is 30 min/div (60-s sampling interval) Maximum sampling length = 100,000 data points × 60 s = 6,000,000 s (approx. 69 days)

Measurement channel: 3, computation channel: 6, internal control channel: 6, external control channel: 3.

Data	Maximum Number of Data Points and Maximum Sampling Length
Display data	Maximum number of data points = $1,200,000 / (3\text{CH} \times 4 \text{ bytes} + 6 \times 8 \text{ bytes} + 6 \times 4 \text{ bytes} + 3 \times 4 \text{ bytes}) = 12,500$ When the display update rate is 30 min/div (60-s sampling interval) Maximum sampling length = 12,500 data points × 60 s = 750,000 s (approx. 8 days)

• Event Data Only

Measurement channel: 4, computation channel: none, internal control channel: none, external control channel: none.

Data	Maximum Number of Data Points and Maximum Sampling Length
Event data	Maximum number of data points = $1,200,000 / (4\text{CH} \times 2 \text{ bytes} + 0 \times 4 \text{ bytes} + 0 \times 2 \text{ bytes}) = 150,000$ However, the maximum is limited to 120,000 data points. Therefore, the maximum number of data points = 120,000 . When the sampling interval of event data is 1 s Maximum sampling length = 120,000 data points × 1 s = 120,000 s (approx. 33 hours)

Appendix 1 Supplementary Explanation of the Acquisition of Display Data/Event Data to the Internal Memory

Measurement channel: 3, computation channel: 6, internal control channel: 6, external control channel: 3.

Data	Maximum Number of Data Points and Maximum Sampling Length
Event data	Maximum number of data points = $1,200,000 / (3CH \times 2 \text{ bytes} + 6 \times 4 \text{ bytes} + 6 \times 2 \text{ bytes} + 3 \times 2 \text{ bytes}) = 25,000$ When the sampling interval of event data is 1 s Maximum sampling length = $25,000 \text{ data points} \times 1 \text{ s} = 25,000 \text{ s}$ (approx. 7 hours)

- **Display Data and Event Data**

Measurement channel: 2, computation channel: none, internal control channel: none, external control channel: none.

Data	Maximum Number of Data Points and Maximum Sampling Length
Display data	Maximum number of data points = $900,000 / (2CH \times 4 \text{ bytes} + 0 \times 8 \text{ bytes} + 0 \times 2 \text{ bytes} + 0 \times 2 \text{ bytes}) = 112,500$ However, the maximum is limited to 75,000 data points. Therefore, the maximum number of data points = 75,000 . When the display update rate is 30 min/div (60-s sampling interval) Maximum sampling length = $75,000 \text{ data points} \times 60 \text{ s} = 4,500,000 \text{ s}$ (approx. 52 days)
Event data	Maximum number of data points = $300,000 / (2CH \times 2 \text{ bytes} + 0 \times 4 \text{ bytes} + 0 \times 2 \text{ bytes} + 0 \times 2 \text{ bytes}) = 75,000$ However, the maximum is limited to 30,000 data points. Therefore, the maximum number of data points = 30,000 . When the sampling interval of event data is 1 s Maximum sampling length = $30,000 \text{ data points} \times 1 \text{ s} = 30,000 \text{ s}$ (approx. 8 hours)

Measurement channel: 3, computation channel: 6, internal control channel: 6, external control channel: 3.

Data	Maximum Number of Data Points and Maximum Sampling Length
Display data	Maximum number of data points = $900,000 / (3CH \times 4 \text{ bytes} + 6 \times 8 \text{ bytes} + 6 \times 4 \text{ bytes} + 3 \times 4 \text{ bytes}) = 9,375$ When the display update rate is 30 min/div (60-s sampling interval) Maximum sampling length = $9,375 \text{ data points} \times 60 \text{ s} = 562,500 \text{ s}$ (approx. 6.5 days)
Event data	Maximum number of data points = $300,000 / (3CH \times 2 \text{ bytes} + 6 \times 4 \text{ bytes} + 6 \times 2 \text{ bytes} + 3 \times 2 \text{ bytes}) = 6,250$ When the sampling interval of event data is 1 s Maximum sampling length = $6,250 \text{ data points} \times 1 \text{ s} = 6,250 \text{ s}$ (approx. 1.7 hours)

Appendix 2 Supplementary Explanation of the Computation Function

This section explains in detail the computation function. It is a supplement to the information covered in “*Computation Function*” in section 1.18, “Computation and Report Functions (Option).” For a description on how to create equations, see *appendix 3, “Meaning and Syntax of Equations.”*

Channel Number to Which the Computation Results Can Be Assigned

The computed results can be assigned to channel numbers [31] to [60]. By selecting these channel numbers on the trend display, you can check the computed results by viewing the trend.

Types of Computations

In the table below, *y* represents the computed result. *X* and *n* represent the measured data of a measurement channel and a constant. For details, see “Data That Can Be Used in Equations.”

Type	Syntax in the Equation	Description
Four arithmetic operation	+, −, *, /	Determines addition, subtraction, multiplication, and division.
Power	**	Determines the power. $y = X^n$
Square root	SQR()	Determines the square root.
Absolute value	ABS()	Determines the absolute value.
Common logarithm	LOG()	Determines the common logarithm. $y = \log_{10}x$
Exponent	EXP()	Determines the exponent. $y = e^x$
Relational computation	.LT., .LE., .GT., .GE., .EQ., .NE.	Determines <, ≤, >, ≥, =, or ≠ of two elements and outputs “0” or “1.”
Logical computation	AND, OR, XOR, NOT	Determines the AND (logical product), OR (logical sum), XOR (exclusive logical sum) of two elements, NOT (negation) of an element and outputs “0” or “1.”
Statistical Computation	TLOG.SUM(), TLOG.MAX(), TLOG.MIN(), TLOG.AVE(), TLOG.P-P(),	Determines the sum (SUM), maximum (MAX), minimum (MIN), average (AVE), and maximum – minimum (P-P) at specified time intervals. There are three timers for setting the interval.
Statistical computation (control)	CLOG.MAX(), CLOG.MIN() CLOG.AVE(). CLOG.P-P()	Determines the maximum (MAX), minimum (MIN), average (AVE), and the difference in the max and min values (P-P) of data measured at the same time.
Conditional expression (control)	[eq1?eq2: eq3]	If the result of eq1 is not 0, eq2 is computed, or if the result of eq1 is 0, equation 3 is computed. If eq1’s computation results in an error, a computation error occurs.

Computation Types That Can Be Used by the Computation Function

Computation type	Measurement computation	PV/SP computation	Analog retransmission	Logic computation
Four rithmetical operations	Yes	Yes	Yes	No
Power	Yes	Yes	Yes	No
Exponent	Yes	Yes	Yes	No
Square root	Yes	Yes	Yes	No
Absolute value	Yes	Yes	Yes	No
Common logarithm	Yes	Yes	Yes	No
Relational operation	Yes	Yes	Yes	No
Logical operation	Yes	Yes	Yes	No
Statistical computation (TLOG)	Yes	No	No	No
Statistical computation (CLOG)	No	Yes	Yes	No
Conditional expressions	Yes	Yes	Yes	Yes

Data That Can Be Used in Equations

For TLOG computation, only measured and computed data can be used. For CLOG computation, only control measured data and measured data can be used. For all other computations, all types of data can be used.

Measured Data

Specify the measured data using channel numbers. If scaling is used, the scaled values are used in the computation.

Computed Data

Specify the computed data using channel numbers.

Internal/External Control Data

Specify internal control channels and external control channels using channel numbers.

Constants (measurement computation: K01 to K30, control compuration: W01 to W36)

The values assigned to K01 to K30 or W01 to W36 can be used as constants. Enter the values as K01 to K30 or W01 to W36 in the equations. Range of Constants (maximum significant digits is 5):

–9.9999E+29 to –1.0000E–30, 0, 1.0000E–30 to 9.9999E+29

Communication Input Data (C01 to C30)

You can use values that are set through communications. Enter the data as C01 to C30 in the equations. For a description on how to set the data, see the *DAQSTATION CX1000/CX2000 Communication Interface User's Manual (IM 04L31A01-17E)*.

Range of values through communication input (maximum significant digits is 5):

–9.9999E+29 to –1.0000E–30, 0, 1.0000E–30 to 9.9999E+29

Status of the Remote Input of the Measurement Alarm Option Terminal Block and the Contact Input of the Control Output Terminal Block/Control DIO Expansion Terminal Block (DI001 to DI006, DI101 to DI106, DI201 to DI206, RI001 to RI012, D01 to D08)

The status of the contact input or remote input signal can be assigned to “1” and “0,” and used in the equations. Enter the data as D01 to D08 (the number following the letter D is the remote input number) in the equations.

The correlation between the status of the remote input signal and the value “1” and “0” are shown below.

Types of Input Signal	Status	Correlation with “1” and “0”
Contact	Closed	1
	Open	0
Open collector	Terminal voltage level is Lo	1
	Terminal voltage level is Hi	0

Status of Control Output Terminal Block/Control DIO Expansion Terminal Block's Contact Output (DO001-DO006, DO101-DO106, DO201-DO206, RO001-RO012)

You can set each contact output status to 1 or 0 and use them for computation.

Internal Switches (SW01-SE36)

You can set each internal switch status to 1 or 0 and use them for computation.

Data Types That Can Be Used in the Computation Function

Computation type	Measurement computation	PV/SP computation	Analog retransmission	Logic computation
Measurement data	Yes	Yes	Yes	Yes
Measurement computed data	Yes	Yes	Yes	Yes
Control measurement data*	No	Yes	Yes	Yes
Internal/external control data	Yes	Yes	Yes	Yes
Constants for measurement computation	Yes	No	No	No
Constants for control computation	No	Yes	Yes	Yes
Communication input data	Yes	Yes	Yes	Yes
Measurement remote input	Yes	Yes	Yes	Yes
Control contact input	Yes	Yes	Yes	Yes
Control expansion contact input	Yes	Yes	Yes	Yes
Control contact output	No	Yes	Yes	Yes
Control expansion contact output	No	Yes	Yes	Yes
Internal switches	No	Yes	Yes	Yes

* When PV/SP computation is OFF.

Handing of the Unit in Computations

The unit corresponding to the measured/computed data in the equation is not compensated

In computations, measured and computed data are handled as values without units. For example, if the measured data from channel 01 is 20 mV and the measured data from channel 02 is 20 V, the computed result of 01 + 02 is 40.

Order of Operations in Equations

The order of operators in equations is as follows. Operators are listed in a decreasing order of precedence.

Type	Operator
	(high order of precedence)
Functions	ABS(), SQR(), LOG(), EXP(), TLOG.MAX(), TLOG.MIN(), TLOG.P-P(), TLOG.SUM(), TLOG.AVE(), CLOG.MAX(), CLOG.MIN(), CLOG.P-P(), CLOG.AVE()
Conditional expression	[eq1?eq2:eq3]
Power	**
Logical negation	NOT
Multiplication and division	*, /
Addition and subtraction	+, -
Greater than and less than	.GT., .LT., GE., LE.
Equal and not equal	.EQ., .NE.
Logical product	AND
Logical sum and exclusive logical sum	OR, XOR
	(low order of precedence)

Displaying the Computed Data

The computed data of computation channels can be displayed in each operation display.

Displaying Waveforms and Bar Graphs

The data are displayed in the range defined by the upper and lower limits of the span. For the procedure in assigning measured data to measurement channels, see *section 10.1, "Assigning Computation Channels and Setting Computing Equations, Constants and Tags."* For the procedure in setting other items related to the display, see *chapter 8, "Operations for Changing the Displayed Contents."*

Numerical Display

The range of displayed values of computed data is from –999999999 to 999999999 excluding the decimal point. The decimal point position corresponds to the position of the decimal point of the upper and lower limit span of the computation channel. On the numerical display, values are displayed if the computed data is within the above range regardless of the upper and lower limits of span.

However, special displays are used for cases given in the table below.

Computed Data Status	Computation Status	Display
When the computed result exceeds 999999999	Positive display overrange	+ *****
When the computed result is less than –999999999	Negative display overrange	– *****
When the value in the middle of the computation exceeds approx. 3.4×10^{38} or below approx. -3.4×10^{38} .	Computation overflow	+ ***** or – *****
During a computation error Computation error occurs when perform the following computation. • X/0 • SQR(–X) • LOG(–X) • If a channel number set to skip is entered in the equation	Error	+ *****
When the stack of the equation (see section 11.2) is greater than or equal to 17	Error	+ *****
When the stack of the control equation is greater than or equal to 35	Error	+ *****

Rolling Average

The rolling average of the computed result of the equation specified for the computation channel is determined, and the result is displayed as computed data for that channel. The sampling interval and the number of samples can be specified for each channel. The maximum sampling interval is 1 hour, and the maximum number of samples is 64. The initial setting is [Off] (do not perform rolling average).

Alarm

Up to 4 alarms can be set to each computation channel. The alarm types are high limit alarm (H), low limit alarm (L), delay high limit alarm (T), and delay low limit alarm (t). The hysteresis is fixed to 0.

Acquisition of Computed Data to the Internal Memory

Display Data and Event Data

Similar to measurement channels, the computed data of computation channels can be acquired to the internal memory as display data/event data.

Manual Sample Data

The instantaneous values of computation channels are acquired to the internal memory through manual sample operation. However, this excludes the measurement channels that are turned [Off].

TLOG Data

The instantaneous values of all channels (excluding measurement channels set to skip and computation channels set to Off) can be saved at intervals specified by a timer.

Note

TLOG computed data and TLOG data are not the same. TLOG computed data refers to the result of the TLOG computation. TLOG data refers to the instantaneous data of specified channels acquired at specified intervals.

No. of Characters in Equations

Measurement computation: 40 characters or less
Control computation: 120 characters or less

Appendix 3 Meaning and Syntax of Equations

This section explains in detail the meaning and syntax of equations. It is a supplement to the information covered in “*Computation Function*” in section 1.18, “*Computation and Report Functions (Option)*” and section 1.19, “*Equation for Control Computation.*”

Four Arithmetic Operations

The data that can be used in equations is as follows: measurement data, computation data, control data, constants (K01-K30), communication input data (C01-C30), remote input status of measurement alarm option terminal block (DO1-DO8), contact input/output status of control output terminal block (DI001-DI006, DI101-DI106, DI201-DI206, DO001-DO006, DO101-DO106, DO201-DO206), contact input/output status of control DIO expansion terminal block (RI001-RI012, RO001-RO012), control measured data (CI01-CI10), constants control computation (W01-W36), and status of internal switches (SW01-SW36). See page App-8 for the data that can be used with control computation and measurement computation.

Equation Examples

- Addition 01+02
(Determines the sum of the measured values of channel 1 and channel 2.)
- Subtraction 01-02
(Determines the difference of the measured values of channel 1 and channel 2.)
- Multiplication 01*K03
(Multiplies constant K03 to the measured value of channel 1.)
- Division 01/K02
(Divides the measured value of channel 1 by constant K02.)

Note

By setting an equation similar to the one shown below, you can determine the accumulation of a specified channel (in this case channel 01) and make the result the computed value of computation channel 31. The computing equation of computation channel 31: 31+01

Power and Other Computations

The data that can be used in equations is as follows: measurement data, computation data, control data, constants (K01-K30), communication input data (C01-C30), remote input status of measurement alarm option terminal block (DO1-DO8), contact input/output status of control output terminal block (DI001-DI006, DI101-DI106, DI201-DI206, DO001-DO006, DO101-DO106, DO201-DO206), contact input/output status of control DIO expansion terminal block (RI001-RI012, RO001-RO012), control measured data (CI01-CI10), constants control computation (W01-W36), and status of internal switches (SW01-SW36). See page App-8 for the data that can be used with control computation and measurement computation. You can also add the computation elements within the parentheses ().

Equation Examples

- Power 01**02
(Determines the measured value of channel 1 to the power of the measured value of channel 2.)
- Square root SQR(02)
(Determines the square root of the measured value of channel 2.)
- Absolute value ABS(02)
(Determines the absolute value of the measured value of channel 2.)
- Common logarithm LOG(01)
(Determines the common logarithm (\log_{10}) of the measured value of channel 1.)

- Exponent EXP(01)
(Determines e to the power of the measured value of channel 1.)

Note

You can determine the natural logarithm by setting an equation like the following.
From $\log_b X = \log^a X / \log_a b$, we obtain $\log_e X = \log_{10} X / \log_{10} e$
Hence, to determine the natural logarithm of channel 1, we set
 $K01 = 0.43429(\log_{10} e)$
and set the equation to $\text{LOG}(01)/K01$.

Relational Computation

The data that can be used in equations is as follows: measurement data, computation data, control data, constants (K01-K30), communication input data (C01-C30), remote input status of measurement alarm option terminal block (DO1-DO8), contact input/output status of control output terminal block (DI001-DI006, DI101-DI106, DI201-DI206, DO001-DO006, DO101-DO106, DO201-DO206), contact input/output status of control DIO expansion terminal block (RI001-RI012, RO001-RO012), control measured data (CI01-CI10), constants control computation (W01-W36), and status of internal switches (SW01-SW36). See page App-8 for the data that can be used with control computation and measurement computation. You can specify a computing equation that performs relational computation on a computing element. (Example: 01.LT.ABS(02))

Equation Examples

02.LT.03

If the measured value of channel 2 is less than the measured value of channel 3, the computed result is "1." Otherwise, the result is "0."

02.GT.03

If the measured value of channel 2 is greater than the measured value of channel 3, the computed result is "1." Otherwise, the result is "0."

02.EQ.03

If the measured value of channel 2 is equal to the measured value of channel 3, the computed result is "1." Otherwise, the result is "0."

02.NE.03

If the measured value of channel 2 is not equal to the measured value of channel 3, the computed result is "1." Otherwise, the result is "0."

02.GE.03

If the measured value of channel 2 is greater than or equal to the measured value of channel 3, the computed result is "1." Otherwise, the result is "0."

02.LE.03

If the measured value of channel 2 is less than or equal to the measured value of channel 3, the computed result is "1." Otherwise, the result is "0."

Logical Computation

Checks whether the two data values, e1 and e2 (e1 only for NOT), are zeroes or non-zeroes, and computes according to the conditions. The data that can be used in equations is as follows: measurement data, computation data, control data, constants (K01-K30), communication input data (C01-C30), remote input status of measurement alarm option terminal block (DO1-DO8), contact input/output status of control output terminal block (DI001-DI006, DI101-DI106, DI201-DI206, DO001-DO006, DO101-DO106, DO201-DO206), contact input/output status of control DIO expansion terminal block (RI001-RI012, RO001-RO012), control measured data (CI01-CI10), constants control computation (W01-W36), and status of internal switches (SW01-SW36). See page App-8 for the data that can be used with control computation and measurement computation. You can specify an equation that performs logical computation on a computing element.

AND

Logical Product

(Syntax) $e1ANDe2$

(Condition) If the two data values $e1$ and $e2$ are both non-zeroes, the computed result is "1." Otherwise, it is "0."

(Explanation)

$e1 = 0$	$e2 = 0$	\rightarrow	$e1ANDe2 = 0$
$e1 \neq 0$	$e2 = 0$	\rightarrow	$e1ANDe2 = 0$
$e1 = 0$	$e2 \neq 0$	\rightarrow	$e1ANDe2 = 0$
$e1 \neq 0$	$e2 \neq 0$	\rightarrow	$e1ANDe2 = 1$

OR

Logical Sum

(Syntax) $e1ORe2$

(Condition) If the two data values $e1$ and $e2$ are both zeroes, the computed result is "0." Otherwise, it is "1."

(Explanation)

$e1 = 0$	$e2 = 0$	\rightarrow	$e1ORe2 = 0$
$e1 \neq 0$	$e2 = 0$	\rightarrow	$e1ORe2 = 1$
$e1 = 0$	$e2 \neq 0$	\rightarrow	$e1ORe2 = 1$
$e1 \neq 0$	$e2 \neq 0$	\rightarrow	$e1ORe2 = 1$

XOR

Exclusive OR

(Syntax) $e1XORe2$

(Condition) If the two data values $e1$ and $e2$ are zero and non-zero or non-zero and zero, the computed result is "1." Otherwise, it is "0."

(Explanation)

$e1 = 0$	$e2 = 0$	\rightarrow	$e1XORe2 = 0$
$e1 \neq 0$	$e2 = 0$	\rightarrow	$e1XORe2 = 1$
$e1 = 0$	$e2 \neq 0$	\rightarrow	$e1XORe2 = 1$
$e1 \neq 0$	$e2 \neq 0$	\rightarrow	$e1XORe2 = 0$

NOT

Logical Negation

(Syntax) $NOTe1$

(Condition) The result is the inverse of the status of data $e1$ (zero or non-zero).

(Explanation)

$e1 = 0$	\rightarrow	$NOTe1 = 1$
$e1 \neq 0$	\rightarrow	$NOTe1 = 0$

Equation Examples**01-02OR03.GT.04**

Determines the OR of the computed results of “01-02” and “03.GT.04”.

TLOG Computation

The data that can be used in TLOG computation is only measured data, computed data, or control data. In the explanation below, e1 is used to represent a measurement or computation channel. You cannot specify an equation that contains a computing element inside e1. In addition, only one TLOG computation can be specified in a single computing equation.

TLOG.MAX()

Maximum Value

(Syntax) TLOG.MAX(e1)

(Condition) Determines the maximum value of channel e1.

TLOG.MIN()

Minimum Value

(Syntax) TLOG.MIN(e1)

(Condition) Determines the minimum value of channel e1.

TLOG.AVE()

Average Value

(Syntax) TLOG.AVE(e1)

(Condition) Determines the average value of channel e1.

TLOG.SUM()

Sum Value

(Syntax) TLOG.SUM(e1)

(Condition) Determines the sum of channel e1.

TLOG.P-P()

Maximum - Minimum Value

(Syntax) TLOG.P-P(e1)

(Condition) Determines the maximum - minimum value of channel e1.

Equation Examples

TLOG.MAX(01)+K01*SQR(02)

Examples of Equations That Are Not Allowed

TLOG.AVE(01)+TLOG.AVE(02)

Reason: TLOG appears twice in one equation.

TLOG.AVE(ABS(01))

Reason: A computing element is used inside the parentheses.

CLOG Computation (Control Computation)

Only measurement data and control measurement data can be used for CLOG computations. In the following explanation, e1 is measurement data or control measurement data. You cannot write an equation that includes computation elements within e1. Also, you cannot add 2 or more CLOG computations in one equation. However, in the following conditional expressions, multiple CLOG computations can be used. Up to 10 computation data items can be used.

CLOG.MAX()

Max. value

(Syntax) CLOG.MAX(e1.e2.e4-e6)

(Conditions) Calculates the maximum value from channels e1, e2, e4, e5, and e6 that were measured at the same time.

CLOG.MIN()

Min. value

(Syntax) CLOG.MIN(e1.e2.e5.e7)

(Conditions) Calculates the minimum value from channels e1, e2, e5, and e7 that were measured at the same time.

CLOG.AVE()

Average

(Syntax) CLOG.AVE(e1-e6)

(Conditions) Calculates the average value from channels e1 through e6 that were measured at the same time.

CLOG.P-P()

Max. value-min. value

(Syntax) CLOG.P-P(e1.e2.e5.e7)

(Conditions) Calculates the minimum-maximum value from channels e1, e2, e5, and e7 that were measured at the same time.

Sample Equation

CLOG.MAX(01.02.CI04-CI06)+K01*SQR(02)

Example of Equation That Cannot Be Used

CLOG.AVE(01.03.05)+CLOG.AVE(02.04.06)

Reason: 2 CLOGs cannot be used in a single equation.

CLOG.AVE(01.ABS(01))

Reason: Computation elements used inside the parentheses.

If Computation Data is Abnormal

You can select the method for processing CLOG computed results if the computation data is abnormal data (burnout error, AD error).

SKIP: Skip any abnormal computation data and complete the computation. Failure diagnostics are output.

ERROR: CLOG computed results in an error.

Conditional Expression (Control Computation)

[eq1?eq2: eq3]

(Syntax) [CI01.GT.W01?CI02:CI03]

(Conditions) If control measurement data 1 is greater than constant W01, control measurement data 2 become the computed results, and if control measurement data 1 is not greater than W01, control measurement data 3 becomes the computed result.

Example of Equation That Cannot Be Used

[CI01.GT.W01?CI02:CI03]: *W02

Reason: Combined with other operators.

Nesting Conditional Expressions

You can substitute conditional expressions for the eq1, eq2, and eq3 in the expression [eq1?eq2:eq3]. For example, you can set a conditional expressions such as [eq1?[eq2-1?eq2-2:eq2-3]:[eq3-1?eq3-2:eq3-3]].

You can nest indefinitely, as long as the total number of characters in the equation does not exceed 120.

Rules for Writing Equations (Common Items)

Follow the rules below when writing computing equations.

- Measurement equation can be entered using up to 40 characters.
- Control equation can be entered using up to 120 characters.
- The precedence of computing terms can be specified using parentheses.
- Specify the channels in the equation using channel numbers.
- One-digit numbers of channels, constants (K), communication input data (C), statuses of remote inputs of the measurement alarm option terminal block (D), statuses of contact inputs of the control output terminal block (DI), and statuses of contact inputs of the control DIO expansion terminal block (RI) used in equations can be expressed as "01" or "1".

Examples: 01, 1, K01, K1, C01, C1, D01, D1

- The data value for the channel used in the equation, and for all channels greater in number than that channel, are substituted with data from the previous scan.
- Do not use more than 16 stacks (channels, K01 to K30, W01 to W30, C01 to C30, D01 to D08) in one equation. Otherwise, a computation error may occur. The computed result displays "+*****" in this case.
Example: The number of stacks in the equation $01+K01*(03+04*K02)$ is five.
- Control measurement data used in PV/SP equations is the data prior to 1 skip.

Note

With control computation, you can compute using a value from the previous iteration of the same computation. For example, given a PV for loop 1 of $PV=101*W01$, the previous value for channel 101(PV of loop 1) can be used. On the other hand, a previous value cannot exist in cases such as immediately after the power is turned ON. If no previous value exists, the above computation result is treated as invalid data, and this invalid status continues in an infinite loop. When computing using a value from the previous iteration of the computation, be sure to use conditions and internal switches that do not result in infinite loops. When computing using a value from the previous iteration of the computation for analog retransmission, if a previous value does not exist, set the computed result to revert to the range lower limit value.

Appendix 4 Additional Explanation of the Report Function

This section is a supplement to the information covered in "Report Function" in section 1.18, "Computation and Report Functions (Option)." For a description on the data format, see the next section, appendix 5, "Data Formats of ASCII Files."

Types of Reports and Their Details

Types of Reports

- **Hourly Report**

Every hour on the hour, the average, maximum, minimum, and sum values of the specified channels are determined from an hour of data up to the current hour and written to the internal memory.

- **Daily Report**

At the specified time every day, the average, maximum, minimum, and sum values of the specified channels are determined from a day of data up to the specified time and written to the internal memory.

- **Weekly Report**

At the specified time of the specified day every week, the average, maximum, minimum, and sum values of the specified channels are determined from a week of data up to the specified time and written to the internal memory.

- **Monthly Report**

At the specified time of the specified date every month, the average, maximum, minimum, and sum values of the specified channels are determined from a month of data up to the specified time and written to the internal memory.

Report Data Output Example (Hourly Report)

Number of the report data being displayed

Number of report data in the internal memory Date/time of the newest report

Type of report Start date/time

Index: 7/13	Kind: Hourly	Start: Aus.07.2001 08:44:28	Timeup: Aus.07.2001 10:39:58
Channel	Unit	Sts	Ave Max Min Sum
TI-001	°C	-0P-	105.0 99999 54.0 2.505371E+05
TI-002	°C	-0P-	33.3 99999 -38.9 7.878073E+04
FI-001	l/min	-0P-	107.50 99999 42.51 2.540787E+05
FI-002	m ³ /h	-0P-	271.4 99999 85.7 6.415446E+05
LI-001	%	-0P-	55.00 99999 11.86 1.229520E+05
FI-003	L/H	-0P-	168.0 99999 12.0 3.970853E+05
CH07	V	-0P-	0.120 99999 -0.320 2.832089E+02

Channel No. or Unit Report data status Average, maximum, minimum, and sum tag name

Combinations of Reports That Can Be Created

The reports created by the CX2000 can be set to "hourly only," "daily only," "hourly and daily," "daily and weekly," or "daily and monthly."

Number of Measurement and Computation Channels That Can Be Assigned to the Report

Up to 30 channels can be assigned to one report.

The report data is not created for channels that are set to [Skip] or those that have the computation turned [Off].

Unit of Sum Computation

In the sum computation, data are summed over the scan interval. However, for flow values that have units /s, /min, /h, or /day a simple summation results in the actual value not matching the computed result, because the scan interval and the unit of the input values are different. In these cases, the unit of the data measured over the scan interval is converted to match the unit of the input values, and the computation is performed. For example, if the scan interval is 2 s, and the input value is 100 m³/min, a simple summation would add 100 every 2 s resulting in 3000 after one minute. However, if the sum unit is set to /min, then 2 s/60 s is multiplied every scan interval before the value is added giving a result that has an m³/min unit.

The following converting equations are used to compute the sum. The scan interval unit is in seconds.

- Off: $\Sigma(\text{measured/computed data every scan interval})$
- /s: $\Sigma(\text{measured/computed data every scan interval}) \times \text{scan interval}$
- /min: $\Sigma(\text{measured/computed data every scan interval}) \times \text{scan interval}/60$
- /h: $\Sigma(\text{measured/computed data every scan interval}) \times \text{scan interval}/3600$
- /day: $\Sigma(\text{measured/computed data every scan interval}) \times \text{scan interval}/86400$

Operation during Power Failures

If a power failure occurs while the report function is in progress, the operation after the power recovers is as follows.

The report function resumes when the power recovers. The exact operation will vary depending on whether the power is restored before or after the scheduled time to create a report.

Time of Recovery	Port Operation
After the time to create the report	Report data is created immediately after power is restored. The measured/computed data up to the time of the power disruption is used. For the next scheduled report, data after the power recovery are used.
Before the time to create the report	After power is restored, report data are created at the time of the next normally scheduled report. The measured/computed data excluding the power disruption period is used.

Handling of Abnormal Data

Handling of the measured/computed data containing abnormal values is as follows.

Type of Abnormal Data	Report Data		
	Average Value	Maximum/Minimum value	Sum
Positive over*	Not used	Used	Not used
Negative over*	Not used	Used	Not used
Error	Not used	Not used	Not used

* "Over range" for measurement channels or "computation overflow" for computation channels.

Displaying the Report

Display

You can display the report by selecting [INFORMATION] > [MEMORY SUMMARY] on the display selection menu in operation mode.

Status Display

If the data of a measurement or a computation channel enters any of the conditions listed below within the relevant time period (one hour for hourly reports and one day for daily reports, for example), status is output to the report.

Data Condition	Status
Common to measurement and computation channels	
Measurement error or computation error	E
For measurement channels	
Positive overrange	O
Negative overrange	O
When the input type is voltage, over range occurs when the measured value exceeds the measurable range of $\pm 5\%$. Suppose the measurement range is 2 V, and the measurable range is -2.000 to 2.000 V. If the measured value exceeds 2.200 V, positive over range results; if the measured value falls below -2.200 V, negative over range results. If the input type is TC (thermocouple) or RTD (resistance temperature detector), over range occurs when the measured value exceeds approximately $\pm 10^\circ\text{C}$ of the measurable range. Suppose the measurement range is R, and the measurable range is 0.0 to 1760.0 $^\circ\text{C}$. If the measured value exceeds 1770.0 $^\circ\text{C}$, positive over range results; if the measured value falls below -10.0 $^\circ\text{C}$, negative over range results.	
For computation channels	
Positive (+) computation overflow (when the value exceeds $3.4\text{E} + 38$)	O
Negative (-) computation overflow (when the value falls below $-3.4\text{E} + 38$)	O
Power Failure/Time Change	Status
When a power failure occurs	P
When the time is changed	C

Appendix 4 Additional Explanation of the Report Function

Numerical Display

The range of displayed values of report data is from –9999999 to 99999999 excluding the decimal point. The decimal point position corresponds to the position of the decimal point of the upper and lower limit span or upper and lower limit scale (for scaling).

However, special displays are used for cases given in the table below.

• Measurement channel

Item	Data Condition of Measurement Channels	Displayed Output
Average value	When all of the data are measurement errors or over range	(Blank)
Maximum and minimum values	<ul style="list-style-type: none">• When all of the data are measurement errors• Positive (+) over range• Negative (-) over range	(Blank) 99999 –99999
Sum value	<ul style="list-style-type: none">• When all of the data are measurement errors or over range• When the sum value exceeds approx. $3.4E + 38$• When the sum value is below approx. $-3.4E + 38$	(Blank) 9.999999E+99 –9.999999E+99

• Computation channel

Item	Data Condition of Computation Channels	Displayed Output
Average value	When all of the data are computation errors or computation overflow	(Blank)
Maximum and minimum values	<ul style="list-style-type: none">• When all of the data are computation errors• When the maximum value exceeds 99999999• When the minimum value is –99999999 <p>The decimal position that was specified when the span for the channel was specified applies to the maximum and minimum values. For example, if the span setting of the channel is “200.0,” then “99999999” is output when the value exceeds “99999999.9” and “–99999999” is output when the value is below “–999999.9.”</p>	(Blank) 99999999 –99999999
Sum value	<ul style="list-style-type: none">• When all of the data are computation errors or computation overflow• When the sum value exceeds approx. $3.4E + 38$• When the sum value is below approx. $-3.4E + 38$	(Blank) 9.999999E+99 –9.999999E+99

Acquiring Report Data to the Internal Memory and Saving Data to the External Storage Medium

Report data is stored to the internal memory at the time reports are created. Up to 40 report data files can be acquired in the internal memory. For the data storage function, see *section 1.17, “Data Storage Function”*.

Appendix 5 Data Format of ASCII Files

This section explains the format of ASCII files. The ASCII files that the CX2000 generates are manual sample files, report files, and setting change log files.

Manual Sample File Format

- The manual sampled data is output using numerical values and strings in ASCII format delimited by commas.
- Channel/tags, units, and manual sample values of channels whose input range is set to [Skip] or computation channels that are turned [Off] are not output.
- The data is appended to the file each time manual sample operation is performed.

Format

```
"MANUAL SAMPLE DATA" CRLF
"Model Serial No.:", "IIIIIIIIIIIIIIIIIIII" CRLF
"File Header:", "HHHHHHHHHHHHHHHHHHHHHHHHHHHHHH" CRLF
"CH/TAG", "cccccccccccccccc", "cccccccccccccccc", ... , "cccccccccccccccc" CRLF
"UNIT", "uuuuuu", "uuuuuu", ... , "uuuuuu" CRLF
yyyy/mo/dd hh:mi:ss, nnn..., nnn..., ... , nnn... CRLF
```

III...I	Serial number of the CX2000 (16 characters)
HHH...H	File header (32 characters)
ccc...c	Channel number or tag name (16 characters)
uuuuuu	Unit (6 characters)
yyyy/mo/dd	Year, month, and date the setup file was created due to setting changes
hh:mi:ss	Time the setup file was created due to setting changes
nnn...n	Measured/computed value (measured value: 8 digits, computed value: 10 digits)

File Output Example

Below is a manual sample example of channels 1, 2, 3, and 4.

```
"MANUAL SAMPLE DATA"
"Model Serial No.:", "12A338617"
"File Header:", "Process1-Lot2"
"CH/TAG", "CH01", "CH02", "CH03", "CH04"
"UNIT", "V", "V", "V", "mV"
2000/01/01 01:08:43, 0.000, 0.000, 0.000, -1.400
2000/01/01 01:08:48, 0.000, 0.000, 0.000, -1.400
2000/01/01 01:09:15, 0.000, 0.000, 0.000, -1.400
"CH/TAG", "CH01", "CH02", "CH03", "CH04"
"UNIT", "V", "V", "V", "V"
2000/01/01 01:15:30, 0.000, 0.000, 0.000, -0.014
2000/01/01 01:18:12, 0.000, 0.000, 0.000, -0.014
```

Note

- Output when error data, overrange data, or computation overflow data is detected

Measurement/Computation Channels	Data	Output
Measurement channel	Error	(Blank)
	Positive overrange	99999
	Negative overrange	-99999
Computation channel	Error	999999999
	Positive (+) computation overflow (when the value exceeds $3.4E + 38$)	999999999
	Negative (-) computation overflow (when the value falls below $-3.4E + 38$)	-999999999

- New line of [CH/TAG], [UNIT] line

In the following cases, a new line is created and the CH/TAG, UNIT line is rewritten.

- A measurement channel is changed to [Skip] from a range other than [Skip].
- A measurement channel is changed to a range other than [Skip] from [Skip].
- A measurement channel is changed from [On] to [Off] or [Off] to [On].
- The unit is changed.

The last four lines of the previous output example is an example when the unit of channel 4 is changed from mV to V.

Report File Format

- The hourly, daily, weekly, and month reports are output using numerical values and strings in ASCII format delimited by commas.
- Channel/tags, units, average values, maximum values, minimum values, and sum values of channels whose input range is set to [Skip] or computation channels that are turned [Off] are not output.
- The data is appended to this file every time a report is created.

Format

```
"TTT..T REPORT", "START TIME", YYYY/MO/DD HH:MI CRLF
"Model Serial No.:", "IIIIIIIIIIIIIIIIII" CRLF
"File Header:", "HHHHHHHHHHHHHHHHHHHHHHHHHHHHHHHH" CRLF
"CH/TAG", "cccccccccccccccc", "cccccccccccccccc", ... , "cccccccccccccccc" CRLF
"UNIT", "uuuuuu", "uuuuuu", ... , "uuuuuu" CRLF
yyyy/mo/dd hh:mi, eeeeeeee, eeeeeeee, ... , eeeeeeee CRLF
"AVE", nnnnnnnnnnnnn, nnnnnnnnnnnnn, ... , nnnnnnnnnnnnn CRLF
"MAX", nnnnnnnnnnnnn, nnnnnnnnnnnnn, ... , nnnnnnnnnnnnn CRLF
"MIN", nnnnnnnnnnnnn, nnnnnnnnnnnnn, ... , nnnnnnnnnnnnn CRLF
"SUM", nnnnnnnnnnnnn, nnnnnnnnnnnnn, ... , nnnnnnnnnnnnn CRLF
```

TTT...T	Title (HOURLY, DAILY, WEEKLY, MONTHLY)
YYYY/MO/DD	Year, month, day the report function was started
HH:MI	Time the report function was started.
III...I	Serial number of the CX2000 (16 characters)
HHH...H	File header (32 characters)
ccc...c	Channel number or tag name (16 characters)
uuuuuu	Unit (6 characters)
eeeeeeee	Status
	E Error (error detection)
	O Over (overrange/computation overflow detection)
	P Power failure (power failure occurrence)
	C Change (time change present)
yyyy/mo/dd	Year, month, day of report
hh:mi	Time of report
nnn...n	Average, maximum, minimum, and sum (13 digits)

File Output Example

Below is an example of a daily report of 4 channels.

```
"DAILY REPORT", "START TIME", 2000/01/31 20:00
"Model Serial No.:", "12A338617"
"File Header:", "Process1-Lot2"
"CH/TAG", "CH01", "CH02", "CH03", "CH04"
"UNIT", "V", "V", "V", "V"
2000/01/01 00:00, "C", "C", "C", "C"
"AVE", 0.00, 0.10, 0.20, 0.30
"MAX", 0.00, 1.00, 2.00, 3.00
"MIN", 0.00, -1.00, -2.00, -3.00
"SUM", 0.000000E-01, 1.000000E+04, 2.000000E+04, 3.000000E+04
```

Note

- If the status of the data of measurement/computation channels is as shown in the following table, status “E” and “O” are output in the report.

Data Condition	Status
Common to measurement and computation channels Measurement error or computation error	E
For measurement channels	
Positive overrange	O
Negative overrange	O
For computation channels	
Positive (+) computation overflow (when the value exceeds 3.4E + 38)	O
Negative (–) computation overflow (when the value falls below –3.4E + 38)	O

- The data of computation/measurement channels that resulted in measurement/computation errors when determining MAX or MIN are not applicable.
- The data of computation/measurement channels that resulted in measurement/computation errors, overrange, or computation overflow when determining AVE or SUM are not applicable.
- The report output values of AVE, MAX, MIN, and SUM are as shown in the following table depending on the data condition of the measurement/computation channels.

Item	Data Condition of Measurement Channels	Report Output Value
AVE (Average value)	When all of the data is measurement errors or over range	(Blank)
MAX, MIN (Maximum, minimum)	<ul style="list-style-type: none"> • When all of the data are measurement errors • Positive (+) over range • Negative (–) over range 	(Blank) 99999 –99999
SUM (Sum value)	<ul style="list-style-type: none"> • When all of the data is measurement errors or over range • When the sum value exceeds approx. 3.4E + 38 • When the sum value is below approx. –3.4E + 38 	(Blank) 9.999999E+99 –9.999999E+99

Item	Data Condition of Computation Channels	Report Output Value
AVE (Average value)	When all of the data are computation errors or computation overflow	(Blank)
MAX, MIN (Maximum, minimum)	<ul style="list-style-type: none"> • When all of the data are computation errors • When the maximum value exceeds 99999999 • When the minimum value is –9999999 	(Blank) 99999999 –9999999
The decimal position that was specified when the span for the channel was specified applies to the maximum and minimum values. For example, if the span setting of the channel is “200.0,” then “99999999” is output when the value exceeds “9999999.9” and “–99999999” is output when the value is below “–999999.9.”		
SUM (Sum value)	<ul style="list-style-type: none"> • When all of the data are computation errors or computation overflow • When the sum value exceeds approx. 3.4E + 38 • When the sum value is below approx. –3.4E + 38 	(Blank) 9.999999E+99 –9.999999E+99

Appendix 6 Initial Values

Basic Setting Mode

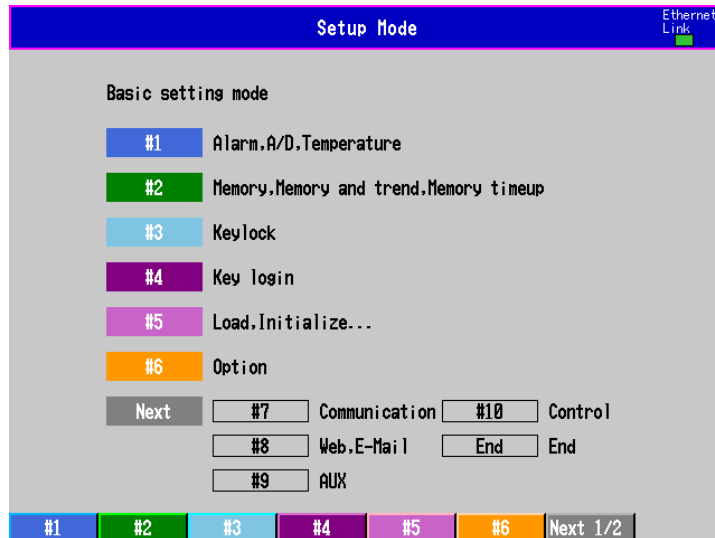

#1 Alarm, A/D, Temperature

Parameter	Initial Value
Alarm > Reflash	Off
Alarm > Relay > AND	None
Alarm > Action	Energize
Alarm > Behavior	Nonhold
Alarm > Indicator	Nonhold
Alarm > Rate of change > Increase/Decrease	1
Alarm > Hysteresis	On
A/D Integrate > Integrate	Auto
A/D > Scan interval	1 s
A/D > First-CH	01
A/D > Last-CH	01
A/D > Burnout set	Off
A/D > RJC	Internal
Temperature > Unit	C

#2 Memory, Memory and trend, Memory timeup

Parameter	Initial Value
Memory > Save	Auto
Memory > Data	Display
Memory and trend > Meas/Math/Loop CH	Meas CH
Memory and trend > First-CH	01
Memory and trend > Last-CH	01
Memory and trend > On/Off	On
Memory timeup > Timeup type	Off

#3 Keylock

Parameter	Initial Value
Keylock > Use/Not	Not

#4 Key login

Parameter	Initial Value
Key login > Use/Not	Not

#5 Load,Initialize

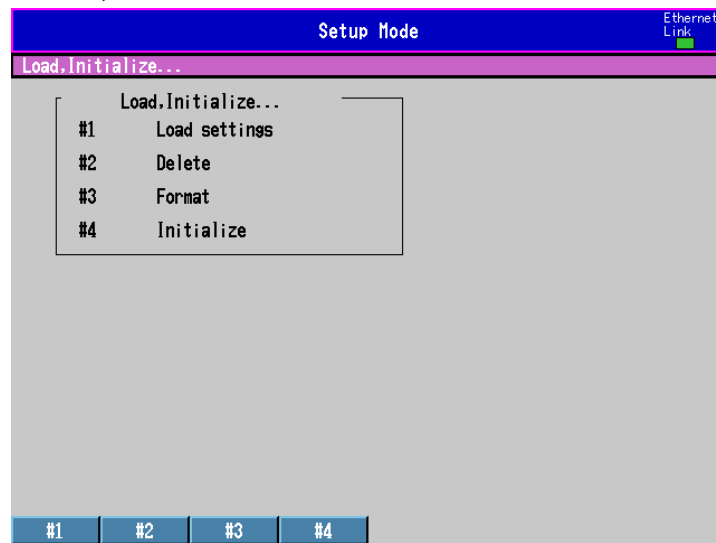

Parameter	Initial Value
Load,Initialize > Load settings	-
Load,Initialize > Delete	-
Load,Initialize > Format	-
Load,Initialize > Initialize	-

#6 Option

Parameter	Initial Value
Remote > Action No. 1 to No. 8	None
Timer(TLOG) NO. 1 > Mode	Absolute
Timer(TLOG) NO. 1> Interval	1 h
Timer(TLOG) NO. 1> Ref.time	0:00
Timer(TLOG) NO. 1> Reset	Off
Timer(TLOG) NO. 1> Action	Off
Timer(TLOG) NO. 2, NO.3 > Mode	Off
Report > Report set	Off
Report > Report CH	R01
Report > Off/On	On
Report > Channel	01
Report > Sum scale	/s

#7 Communication

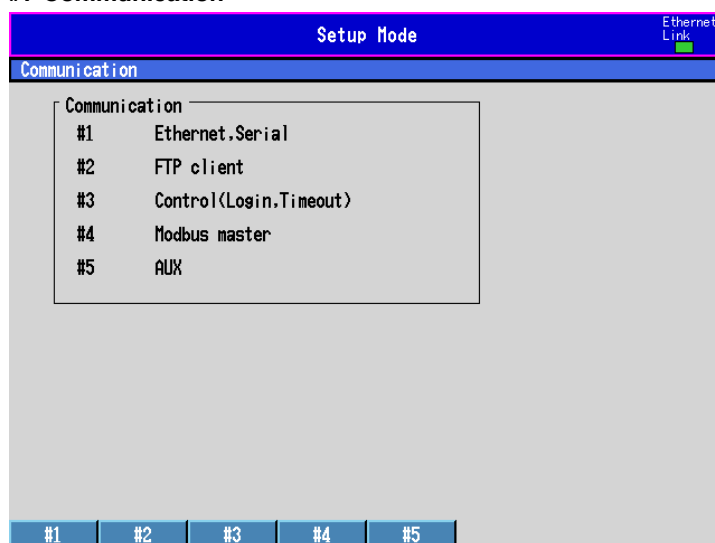

<#1 Ethernet,Serial>

Parameter	Initial Value
Ethernet > IP-address	0.0.0.0
Ethernet > Subnet mask	0.0.0.0
Ethernet > Default gateway	0.0.0.0
Ethernet > DNS On/Off	Off
Ethernet > Server search order > Primary	0.0.0.0
Ethernet > Server search order > Secondary	0.0.0.0
Ethernet > Host name	-
Ethernet > Domain name	-
Ethernet > Domain suffix search order > Primary	-
Ethernet > Domain suffix search order > Secondary	-
Serial > Baud rate	9600 bps
Serial > Data length	8 bit
Serial > Parity	Even
Serial > RS-232 > Handshaking	Off:Off
Serial > RS-422/485 > Address	1
Serial > RS-422/485 > Protocol	Normal
Memory output	Ethernet

<#2 FTP client>

Parameter	Initial Value
FTP transfer file > Disp&Event data	Off
FTP transfer file > Report	Off
FTP connection	Primary
FTP connection > FTP server name	-
FTP connection > Port number	21
FTP connection > Login name	-
FTP connection > Password	-
FTP connection > Account	-
FTP connection > PASV mode	Off
FTP connection > Initial path	-

<#3 Control(Login,Timeout)>

Parameter	Initial Value
Ethernet login > Use/Not	Not
Application time out > On/Off	Off
Keep alive > On/Off	On

<#4 Modbus master>

Parameter	Initial Value
Basic settings > Read cycle	2 s
Basic settings > Timeout	2 s
Basic settings > Retrials	Off
Command Settings > 1 to 8	Off

<#5 AUX>

Parameter	Initial Value
Recovery status for Comm. Buffer > DO/SW	Clear
Modbus master/Ext loop > Auto recovery	Off

#8 Web,E-Mail

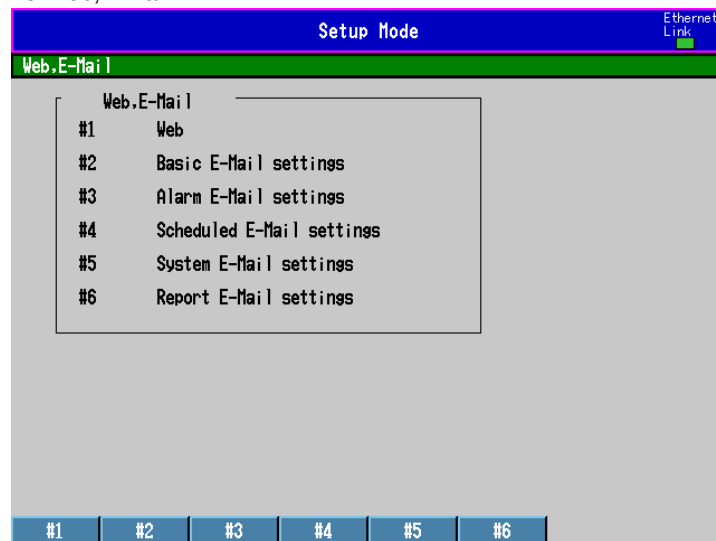

<#1 Web>

Parameter	Initial Value
Web > Use/Not	Not

<#2 Basic E-Mail Settings>

Parameter	Initial Value
Basic E-Mail settings > SMTP server name	-
Basic E-Mail settings > Port number	25
Basic E-Mail settings > Recipient 1	-
Basic E-Mail settings > Recipient 2	-
Basic E-Mail settings > Sender	-

<#3 Alarm E-Mail Settings>

Parameter	Initial Value
Alarm E-Mail settings > Recipient1	Off
Alarm E-Mail settings > Recipient2	Off
Alarm E-Mail settings > Alarm1 to 4	Off
Alarm E-Mail settings > Include INST	Off
Alarm E-Mail settings > Include source URL	Off
Alarm E-Mail settings > Subject	<CX>Alarm_summary
Alarm E-Mail settings > Header1	-
Alarm E-Mail settings > Header2	-

<#4 Scheduled E-Mail Settings>

Parameter	Initial Value
Scheduled E-Mail settings > Recipient1	Off
Scheduled E-Mail settings > Interval	24h
Scheduled E-Mail settings > Ref.time	00:00
Scheduled E-Mail settings > Recipient2	Off
Scheduled E-Mail settings > Interval	24h
Scheduled E-Mail settings > Ref.time	00:00
Scheduled E-Mail settings > Include INST	Off
Scheduled E-Mail settings > Include source URL	Off
Scheduled E-Mail settings > Subject	<CX>Periodic_data
Scheduled E-Mail settings > Header1	-
Scheduled E-Mail settings > Header2	-

<#5 System E-Mail Settings>

Parameter	Initial Value
System E-Mail settings > Recipient1	Off
System E-Mail settings > Recipient2	Off
System E-Mail settings > Include source URL	Off
System E-Mail settings > Subject	<CX>System_waning
System E-Mail settings > Header1	-
System E-Mail settings > Header2	-

<#6 Report E-Mail Settings>

Parameter	Initial Value
Report E-Mail settings > Recipient1	Off
Report E-Mail settings > Recipient2	Off
Report E-Mail settings > Include source URL	Off
Report E-Mail settings > Subject	<CX>Report_data
Report E-Mail settings > Header1	-
Report E-Mail settings > Header2	-

#9 Aux, Time zone

Parameter	Initial Value
AUX > Tag/Channel	Tag
AUX > Memory alarm	1h
AUX > Language	English
AUX > Partial	Not
Time zone > Difference from GMT	0

#10 Control

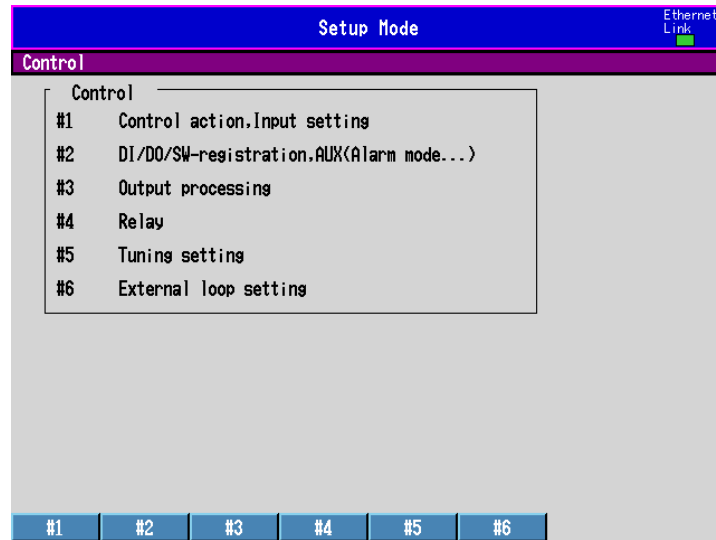

<#1 Control action, Input setting>

Parameter	Initial Value
Control action > PID number	8
Control action > Control period	250ms
Control action > Zone PID	Off
Control action > Restart mode	Continue
Control action > Initial PID	Temp
Control action > 6/4loop select	6loop
Control action > Auto tuning	Off
Control action > Loop number	1
Control action > Control mode	Single
Control action > Program control	Off
Control action > PID control mode	Follow-up
Input setting > Loop number	1
Input setting > Burnout > Measure1	up
Input setting > Burnout > Measure2	up
Input setting > Burnout > Remote	up
Input setting > RJC > Measure1	Internal
Input setting > RJC > Measure2	Internal
Input setting > RJC > Remote	Internal

<#2 DI/DO/SW-registration, AUX (Alarm mode...)>

Parameter	Initial Value
DI/DO/SW-registration > Module	CTRL1-2
DI/DO/SW-registration > DI101 to 106	None
DI/DO/SW-registration > RI001 to 012	None
AUX > Loop number	1
AUX > Remote setting	Off
AUX > Alarm mode	ALWAYS
AUX > SP No. selection source > Loop number 1 to 6	1: On, 2-6: Off
AUX > PV/SP math	Off
AUX > CLOG error	Error
AUX > Event output setting	Separate

<#3 Output processing>

Parameter	Initial Value
Loop number	1
Control output	Current-output
Cycle time	30s
Analog-output type	4-20mA

<#4 Relay>

Parameter	Initial Value
Relay > Module	CTRL1-2
Relay > FAIL	Off
Relay > Self diagnosis	Off
Relay > DO001 to 006	Energize/Nonhold
Relay > RO001 to 012	Energize/Nonhold

<#5 Tuning setting>

Parameter	Initial Value
Tuning setting > Loop number	1
Tuning setting > 01 to 21	01 to 12: On, 13 to 21: OFF
Tuning setting > 01 to 21 > Item ID	01: SP, 02: A1, 03: A2, 04: A3, 05: A4, 06: P, 07: I, 08: D, 09: OH, 10: OL, 11:MR, 12: PO

<#6 External loop setting>

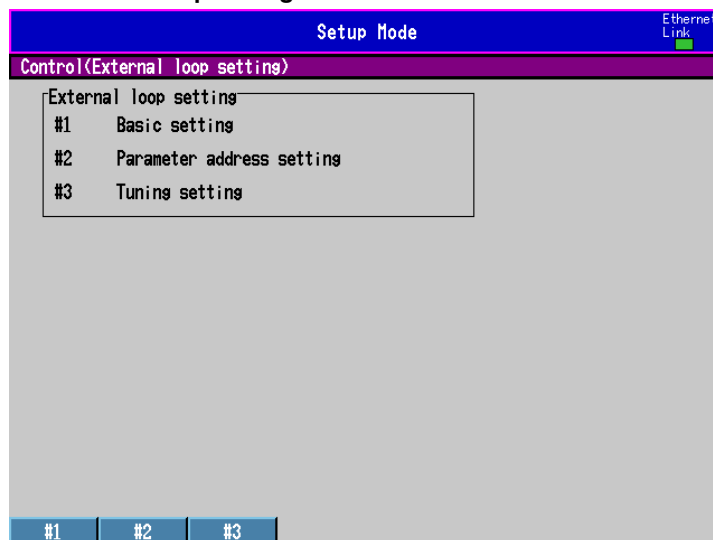

Parameter	Initial Value
#1 Basic setting	
Loop number	Ext1
Comm. Off/On	Off
#2 Parameter address setting	
Loop number	Ext1
PV : Input	40003
SP : Setting	40004
OUT : Output	40005
Control mode	40008
Remote/Local	40008
Operation STOP/RUN	40205
Alarm value	40011
SP number	40010
PID number	40009
Auto reading	

Appendix 6 Initial Values

Parameter	Initial Value
#3 Tuning setting	
Tuning setting > Loop number	Ext1
Tuning setting > 01 to 21	Off

Setting mode(Control)

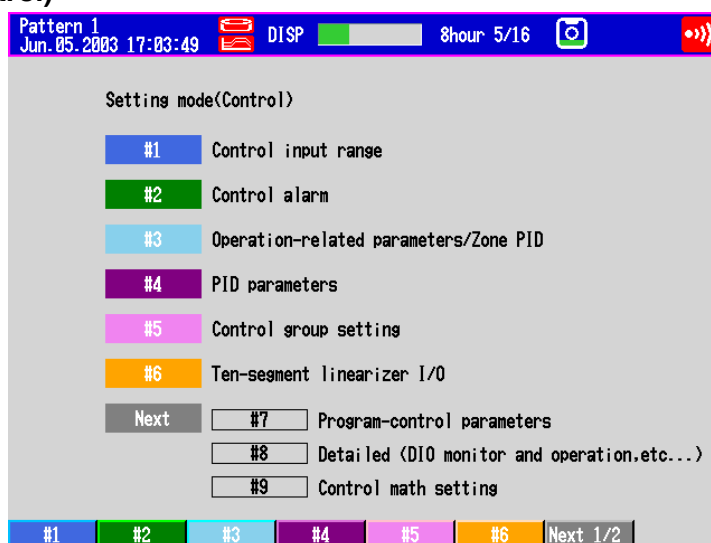

#1 Control input range

Parameter	Initial Value
Input range > Loop number	1
Input range > Input type	PV1
Input range > Mode	TC
Input range > Range	K
Input range > Span Lower-limit	-200.0
Input range > Span Upper-limit	1370.0
Input range > Square root	Off
Bias	Off
Filter	Off

#2 Control alarm

Parameter	Initial Value
Alarm > Loop number	1
Alarm > 1 to 4	Off
Alarm > SP number	1
Alarm > Alarm value 1 to 4	1370.0

#3 Operation related/zone PID

Parameter	Initial Value
Operation related/zone PID > Loop number	1
Operation related/zone PID > Suppressing function	Off
Operation related/zone PID > Ramp-rate time unit	Hour
Operation related/zone PID > SP ramp-down-rate	Off
Operation related/zone PID > SP ramp-up-rate	Off
Tag	INT-01
Tag comment	-

#4 PID parameters

Parameter	Initial Value
PID parameters > Loop number	1
PID parameters > PID Number	1
PID parameters > Target setpoint	-200.0
PID parameters > Proportional band(P)	5.0%
PID parameters > Integral time(I)	240 s
PID parameters > Derivative time(D)	60 s
PID parameters > Output lower limit	0.0%
PID parameters > Output upper limit	100.0%
PID parameters > Shutdown	Off
PID parameters > Manual reset	50.0%
PID parameters > Reverse/Direct	Reverse
PID parameters > Preset output	0.0%

#5 Control group setting

Parameter	Initial Value
Control group > Group number	1
Control group > Group name	CONTROL GROUP1
Control group > 1 to 6 > ON/OFF	On
Control group > 1 to 6 > Kind	Int-Loop
Control group > 1 to 6 > Number	01-06

#6 Ten-segment linearizer I/O

Parameter	Initial Value
Ten-segment linearizer I/O > Loop number	1
Ten-segment linearizer I/O > Input type	PV1
Ten-segment linearizer I/O > Mode	Off

#7 Program control related (only when program control is ON)

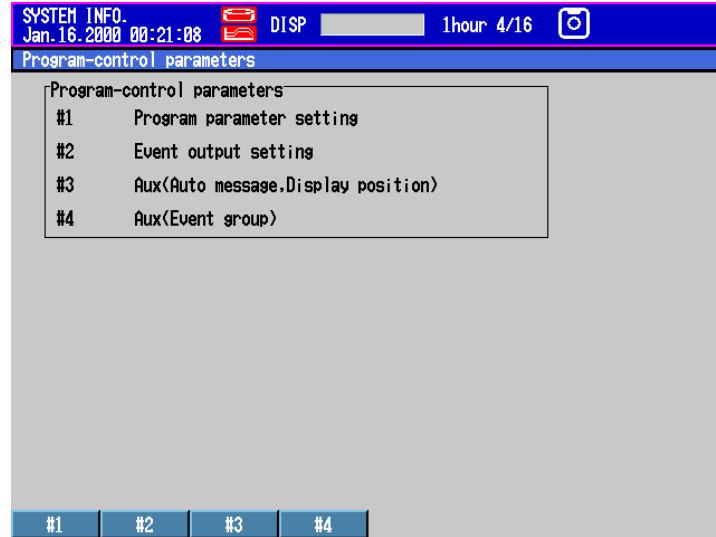

<#1 Program parameter setting>

Parameter	Initial Value
#1 Pattern initial setting	
Program initial setting > Pattern number	1
Program initial setting > Segments	0
Program initial setting > Segment setting method	Time
Program initial setting > Pattern name	Pattern 1
Program initial setting > Action loop	Off

Parameter	Initial Value
#2 Wait action setting	
Wait action setting > Wait zone 1 to 5	Off
Wait action setting > Wait time	00:00:00
#3 Pattern start setting	
Pattern start setting > Start target setpoint > Loop 1 to 6	-200.0
Pattern start setting > Start code	StartTargetSP
#4 Program pattern setting	
Program pattern setting > Segment number	1
Program pattern setting > Ramp/Soak select	Ramp
Program pattern setting > Target setpoint > Loop 1 to 6	-200.0
Program pattern setting > Segment time	00:00:00
Program pattern setting > Segment PID group No.	1
Program pattern setting > Segment shift action	Continue
Program pattern setting > Wait action	Off
#5 Event setting	
Event setting > Segment number	1
Event setting > Event kind	TimeEvent
Event setting > 1 to 16	Off
#6 Hysteresis (PV event)	
Hysteresis (PV event) > PV event 1 to 16	0.5%
#7 Repeat action setting	
Repeat action setting > Repeat action	Off

<#2 Event output setting >

Parameter	Initial Value
Event output > Pattern number	1
Event output > Event kind	TimeEvent
Event output > EV1 to 16 > Relay Output	Off
Program pattern end signal > Relay Output	Off

<#3 AUX (Auto message, Display position)>

Parameter	Initial Value
AUX (Auto message, Display position) > Auto message for program Run/Reset On/Off	On
AUX (Auto message, Display position) > Program display position > Position > Loop 1 to 6	Loop 1 to 6: 1 to 6
AUX (Auto message, Display position) > Auto change to program run display	Off

<#4 AUX (Event group)>

Parameter	Initial Value
AUX (Event group) > Pattern number	1
AUX (Event group) > 1 to 5	On
AUX (Event group) > Kind	Time Event
AUX (Event group) > Number	1 to 5: 01 to 05

#8 Detailed setting (#7 when the program control function is OFF)

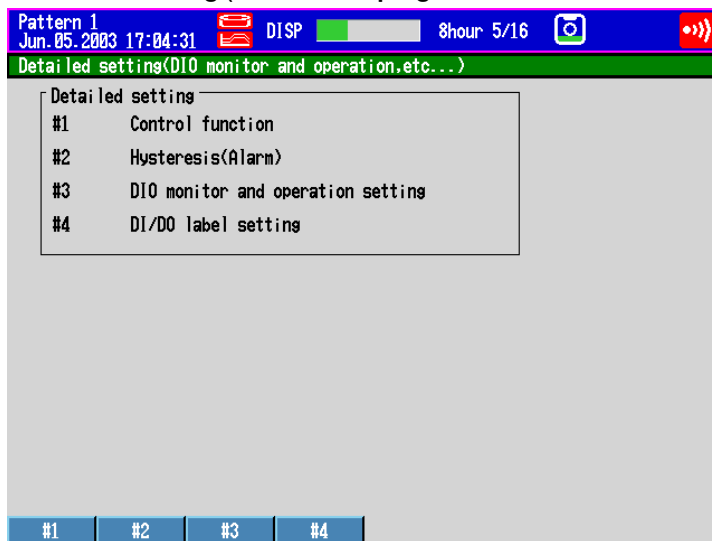

<#1 Control function>

Parameter	Initial Value
Control function > Loop number	1
Control function > SP Tracking	On
Control function > PV Tracking	Off
Control function > Target setpoint limiter > Lower	-200.0
Control function > Target setpoint limiter > Upper	1370.0
Control function > Output velocity limiter	Off
Control function > Anti-reset windup	Auto

<#2 Hysteresis (Alarm)>

Parameter	Initial Value
Hysteresis (Alarm) > Alarm > Loop number	1
Hysteresis (Alarm) > Alarm > Hysteresis 1 to 4	7.8

<#3 DIO monitor and operation setting>

Parameter	Initial Value
DIO monitor and operation setting > DIO entry number	01
DIO monitor and operation setting > On/Off	Off

<#4 DI/DO label setting>

Parameter	Initial Value
DI/DO label setting > Module	CTRL1-DI
DI/DO label setting > Label	DI001 to DI006: DI001 to DI006

#9 Control math setting (#8 when the program control function is OFF)

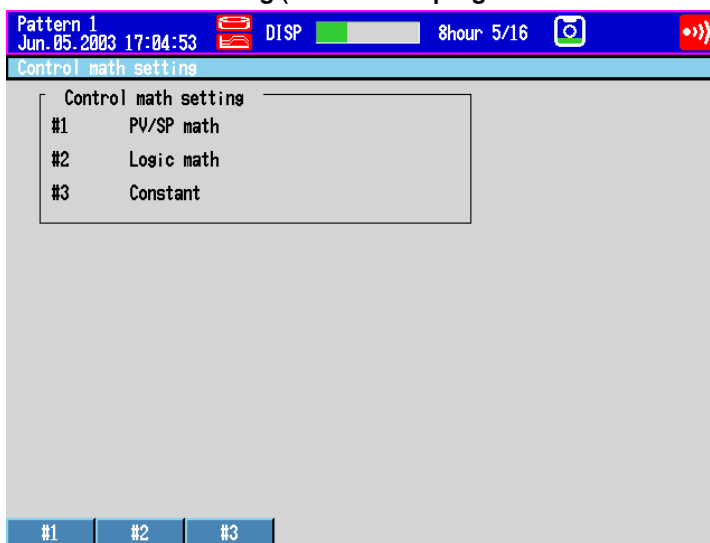

<#1 PV/SP math, Retransmission>

Parameter	Initial Value
PV/SP math, Retransmissin > Loop number	1 to 6
PV/SP math, Retransmissin > PV/SP	PV
PV/SP math, Retransmissin > Mode	Off
PV/SP math, Retransmissin > Calculation expression	Loop number 1 to 6: C101 to C110
PV/SP math, Retransmissin > Math error	Over

<#2 Logic math>

Parameter	Initial Value
Logic math > Setting number	1-6
Logic math > Relay	Off

<#3 Constant>

Parameter	Initial Value
Constant > W01 to W36	1

Set mode

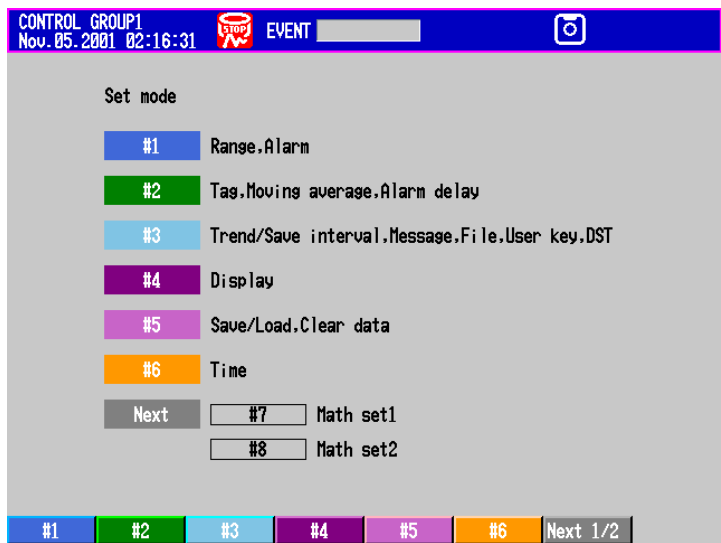

#1 Range,alarm

Parameter	Initial Value
First-CH	01
Last-CH	01
Range > Mode	Volt
Range > Range	2 V
Range > Span Upper	-2.000
Range > Span Lower	2.000
Alarm > 1 to 4	Off

#2 Tag, Moving average, Alarm delay

Parameter	Initial Value
First-CH	01
Last-CH	01
Tag	01
Moving average > Count	Off
Alarm delay Time	10 s

#3 Trend/Save interval, Message, File, User key, DST

Parameter	Initial Value
Trend/Save interval > Time/div	1min
Trend/Save interval > Auto save interval	1 h
Message > Characters No. 1 to No. 8	Space
File > Header	Space
File > Directory name	DATA0
USER key > Action	AlarmACK
Daylight saving time (YY/MM/DD HH) > Summer	Off
Daylight saving time (YY/MM/DD HH) > Winter	Off

#4 Display



<#1 Group set, Trip line>

Parameter	Initial Value
Group number	1
Group set > Group name	GROUP1
Group set > CH set	01-10
Group set > Trip line > No. 1 to No. 4	Off

<#2 Color>

Parameter	Initial Value
Color > CH1	Red
Color > CH2	Green
Color > CH3	Blue
Color > CH4	Blue violet
Color > CH5	Brown
Color > CH6	Orange
Color > CH7	Yellow green
Color > CH8	Light blue
Color > CH9	Violet
Color > CH10	Gray

<#3 Zone, Graph, Partial

Parameter	Initial Value
First-CH	01
Last-CH	01
Zone > Lower	0%
Zone > Upper	100%
Graph > Division	10
Graph > Bar graph	Normal
Graph > Scale position	1

Appendix 6 Initial Values

<#4 View,Direction,LCD>

Parameter	Initial Value
View > Direction > Trend	Horizontal
View > Direction > Bar graph	Vertical
View > Background > Measure	White
View > Background > Control	Black
View > Trend line	2 dot
View > Trip line	2 dot
View > Grid	10 div
View > Scroll	5 s
View > Scale digit	Normal
LCD > Brightness	3
LCD > Backlight saver > On/Off	Off

<#5 Control(Color)>

Parameter	Initial Value
Select	Internal
CH101, CH110	Red
CH102, CH111	Green
CH103, CH112	Blue
CH104, CH113	Blue violet
CH105, CH114	Brown
CH106, CH115	Orange
CH107, CH116	Yellow green
CH108, CH117	Light blue
CH109, CH118	Violet

<#6 Control(Zone,Graph,Partial)>

Parameter	Initial Value
First-CH	101
Last-CH	101
Zone Lower	0
Zone Upper	100
Division	10
Bar graph	Normal
Scale position	1

<#7 Math(Color)>

Parameter	Initial Value
Select	Internal
CH31, CH41, CH51	Red
CH32, CH42, CH52	Green
CH33, CH43, CH53	Blue
CH34, CH44, CH54	Blue violet
CH35, CH45, CH55	Brown
CH36, CH46, CH56	Orange
CH37, CH47, CH57	Yellow green
CH38, CH48, CH58	Light blue
CH39, CH49, CH59	Violet
CH40, CH50, CH60	Gray

<#8 Math(Zone,Graph,Partial)>

Parameter	Initial Value
First-CH	31
Last-CH	31
Zone > Lower	0%
Zone > Upper	100%
Graph > Division	10
Graph > Bar graph	Normal
Graph > Scale position	1

#5 Save/Load,Clear data

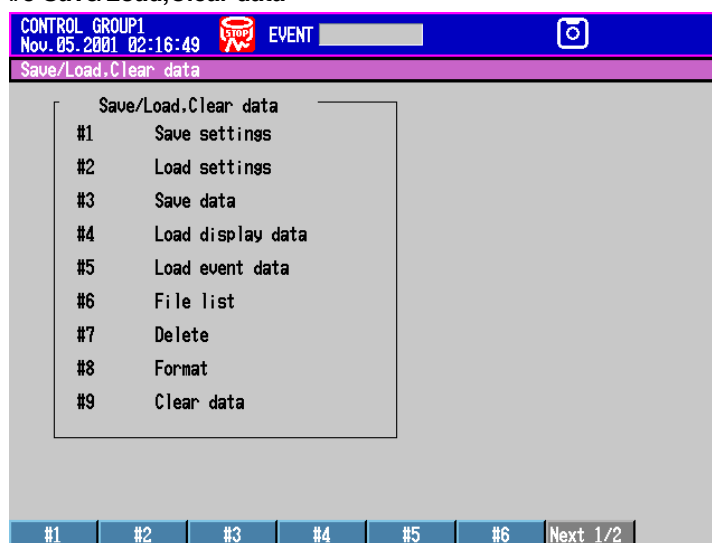

Parameter	Initial Value
#1 Save settings	–
#2 Load settings	–
#3 Save data	–
#4 Load display data	–
#5 Load event data	–
#6 File list	–
#7 Delete	–
#8 Format	–
#9 Clear data	–

#6 Time

Parameter	Initial Value
Time set	–

#7 Math set1

Parameter	Initial Value
First-CH	31
Last-CH	31
Math range > Math	Off
Math Alarm > 1 to 4	Off
Constant > K01 to K30	–

#8 Math set2

Parameter	Initial Value
First-CH	31
Last-CH	31
Tag > Tag	31
TLOG > Timer No.	1
TLOG > Sum scale	Off
Rolling average > On/Off	Off
Alarm delay > Time	10 s

Appendix 7 Control Function Block Diagram

Single Loop Control (Fixed-Point Control)

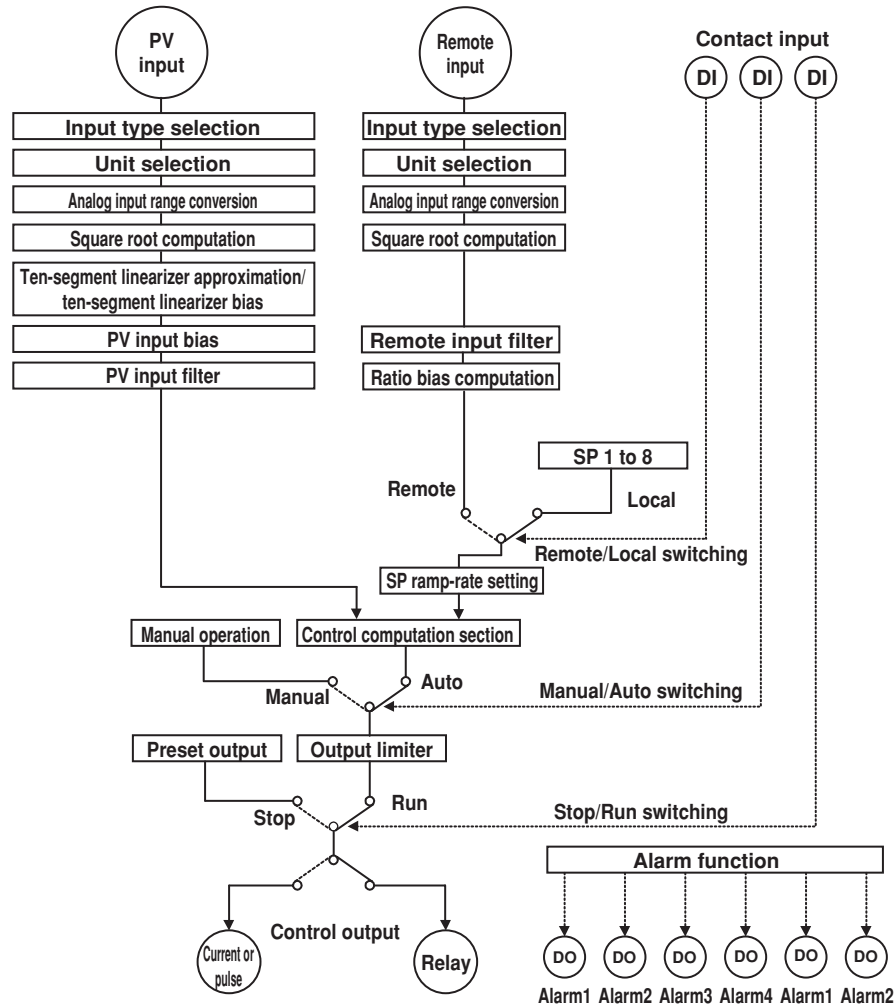

Note: There are 6 contact input terminals and 6 contact output terminals on a single control output terminal block. The functions that can be assigned to each input/output terminal vary depending on the control mode and whether program operation is enabled.

Single Loop Control (Program Control)

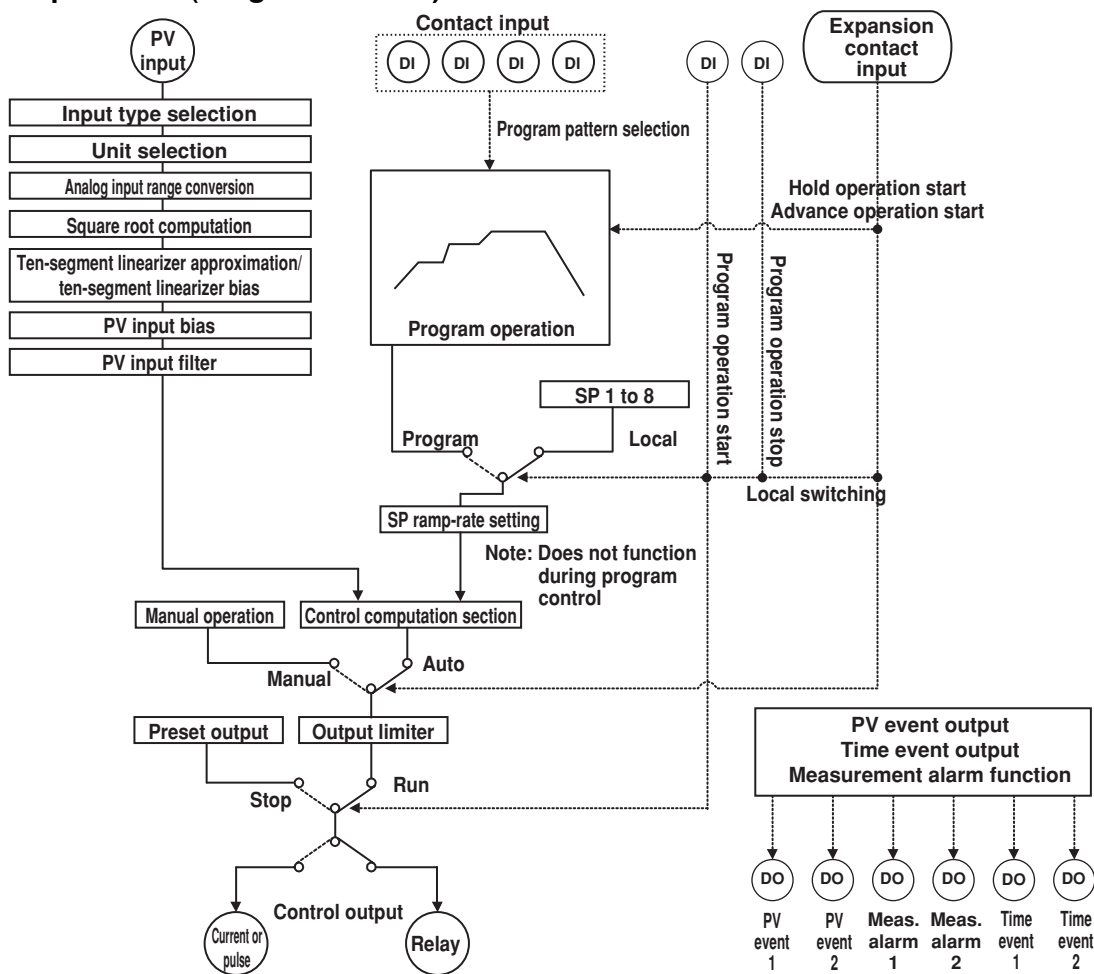

Note: There are 6 contact input terminals and 6 contact output terminals on a single control output terminal block. The functions that can be assigned to each input/output terminal vary depending on the control mode and whether program operation is enabled.

Cascade Control (Fixed-Point Control)

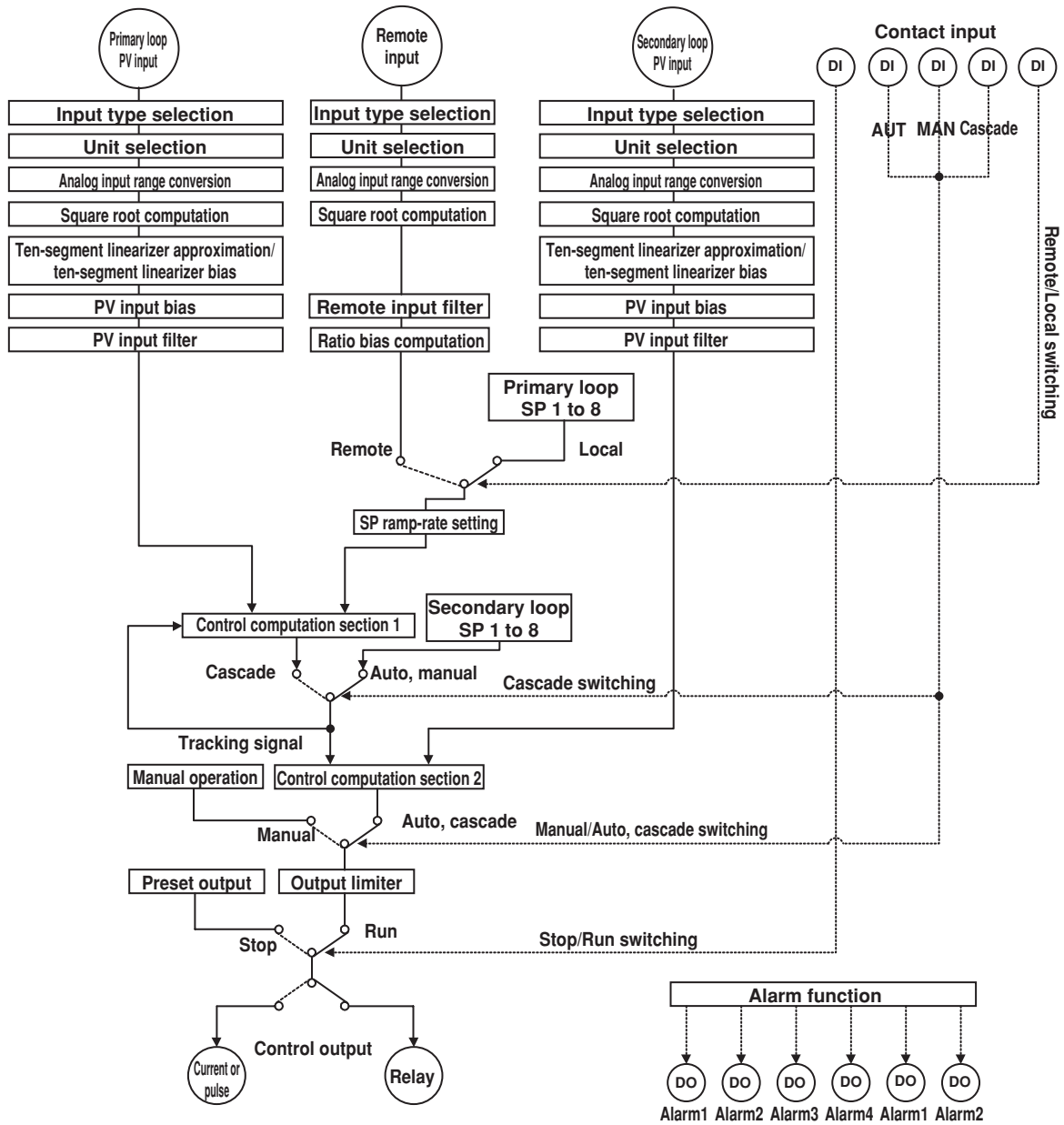

Note: There are 6 contact input terminals and 6 contact output terminals on a single control output terminal block. The functions that can be assigned to each input/output terminal vary depending on the control mode and whether program operation is enabled.

Cascade Control (Program Control)

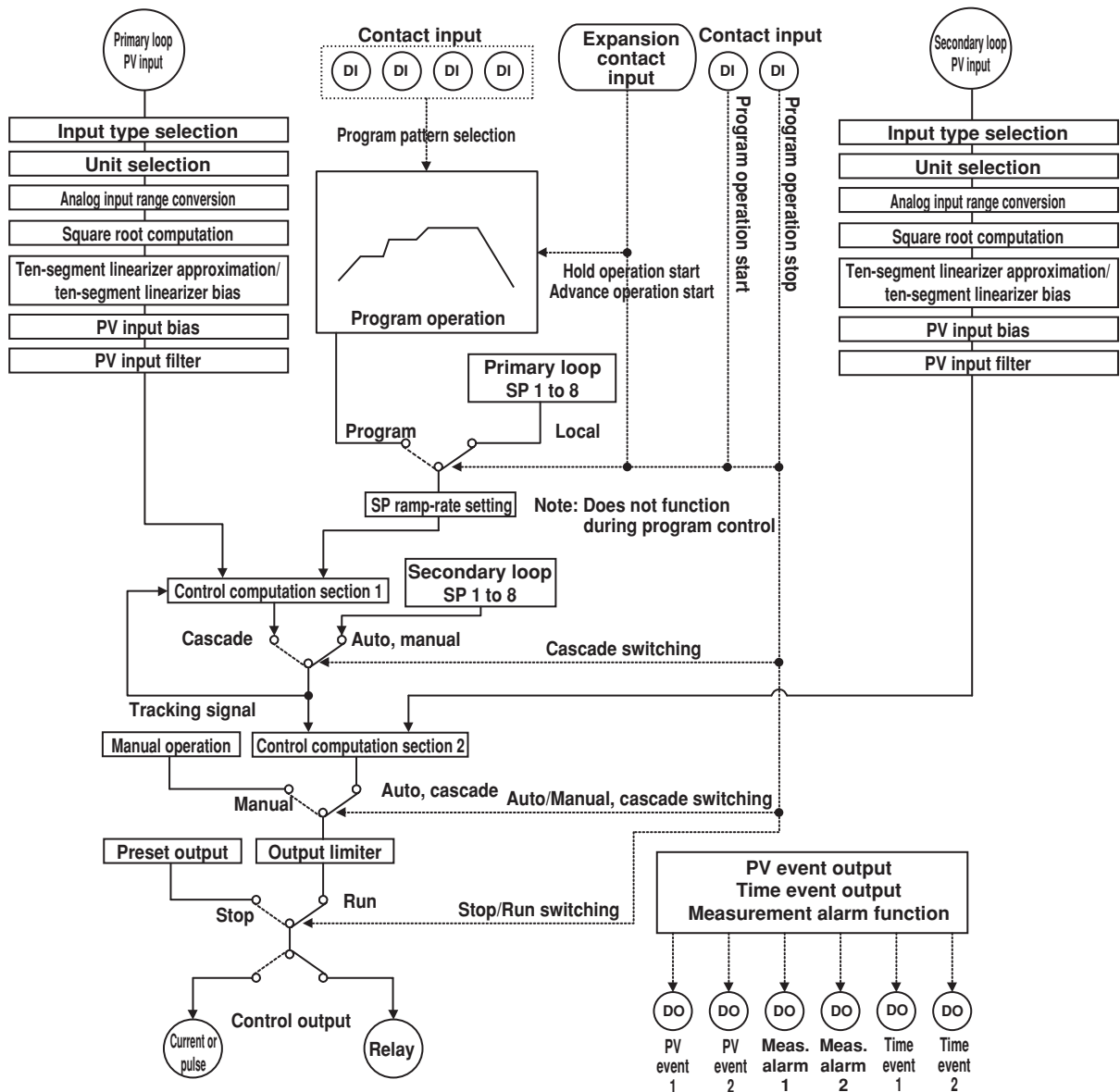

Note: There are 6 contact input terminals and 6 contact output terminals on a single control output terminal block. The functions that can be assigned to each input/output terminal vary depending on the control mode and whether program operation is enabled.

Loop Control with PV Switching (Fixed-Point Control)

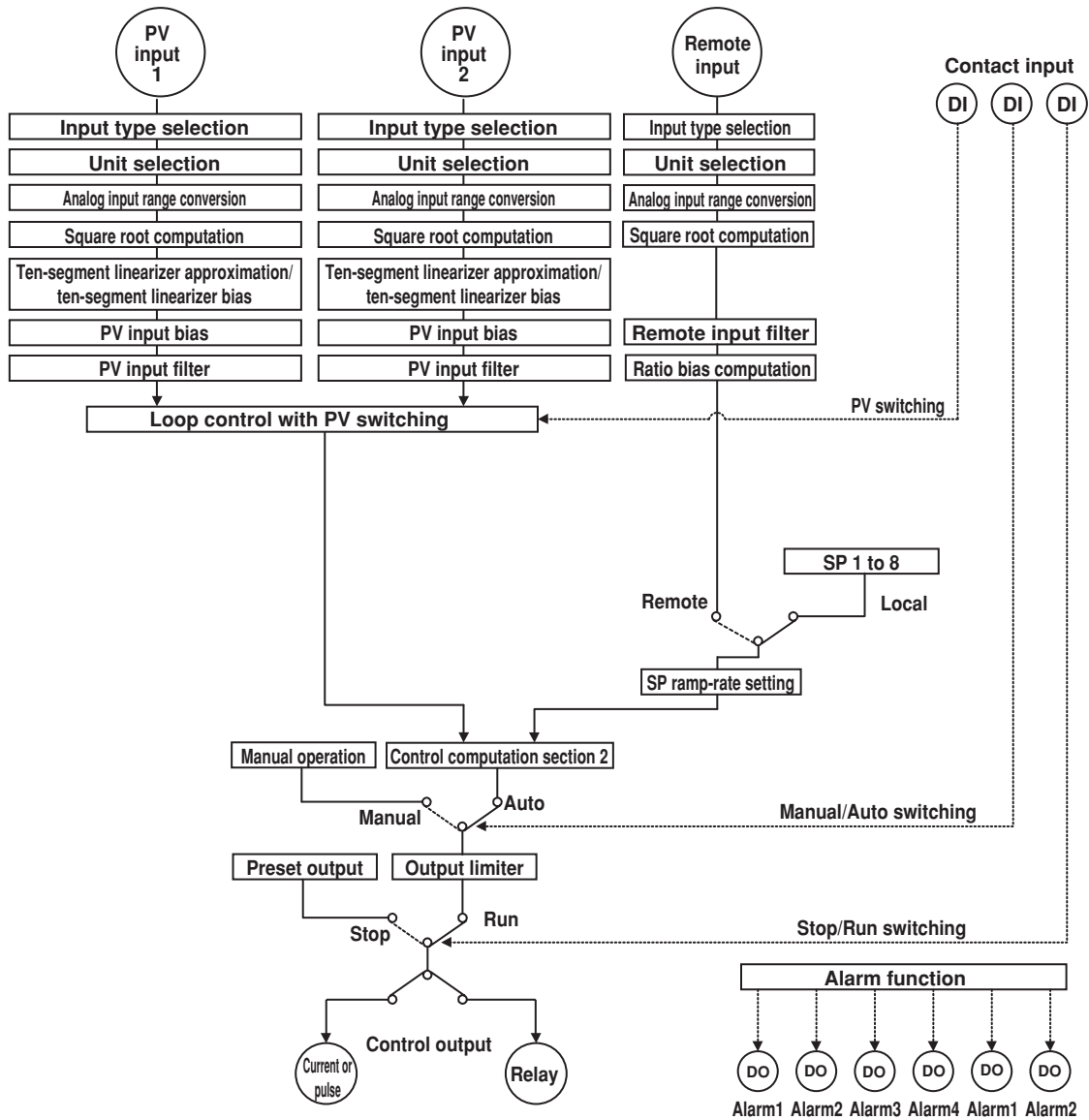

Note: There are 6 contact input terminals and 6 contact output terminals on a single control output terminal block. The functions that can be assigned to each input/output terminal vary depending on the control mode and whether program operation is enabled.

Loop Control with PV Switching (Program Control)

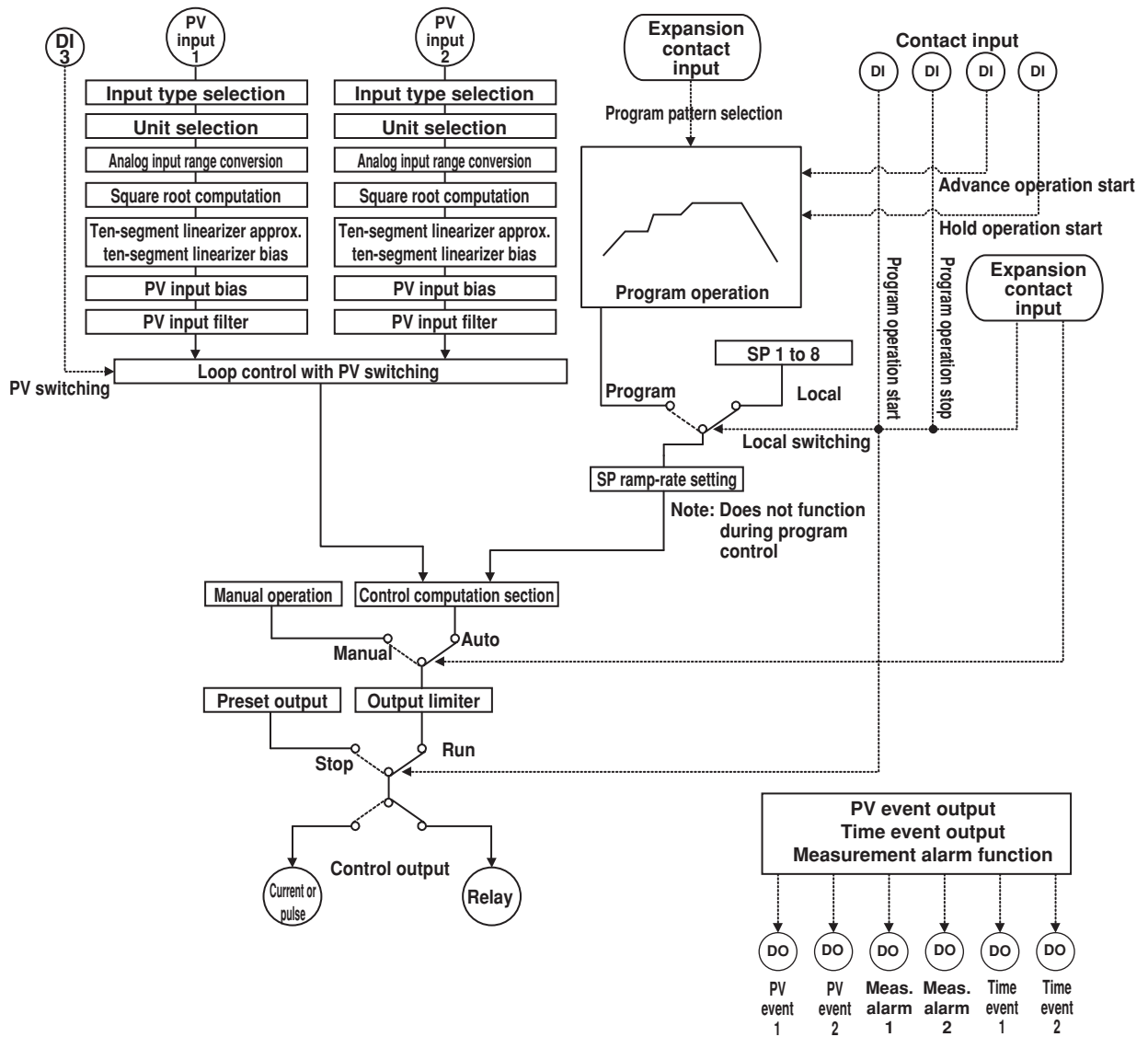

Note: There are 6 contact input terminals and 6 contact output terminals on a single control output terminal block. The functions that can be assigned to each input/output terminal vary depending on the control mode and whether program operation is enabled.

Analog Retransmission

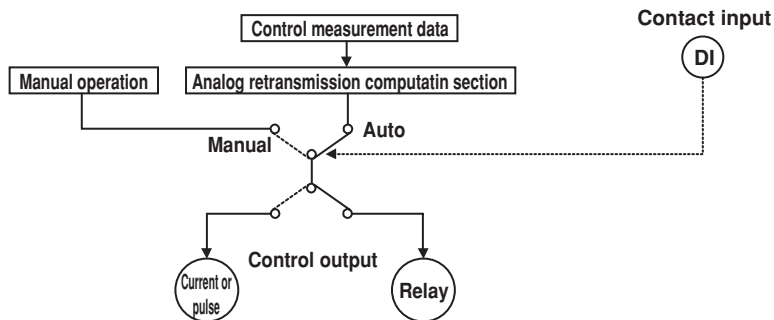

Appendix 8 Explanation of Engineering Units (EU and EUS)

The CX2000 uses the following two types of engineering units as units for the internal data.

The PV is indicated using the engineering unit of the measurement span (the range used by control within the PV range).

- EU(): Unit indicating the value using the engineering unit where the low and high limits of measurement span are EU (0%) and EU (100%), respectively.
- EUS(): Unit indicating the amount of percentage the value occupies against the width of the measurement span using engineering units.

Below is an example of values converted to EU() and EUS().

If the measurement span is set to -200 to 1200 °C, EU (20%) is 80 °C and EUS (20%) is 280 °C.

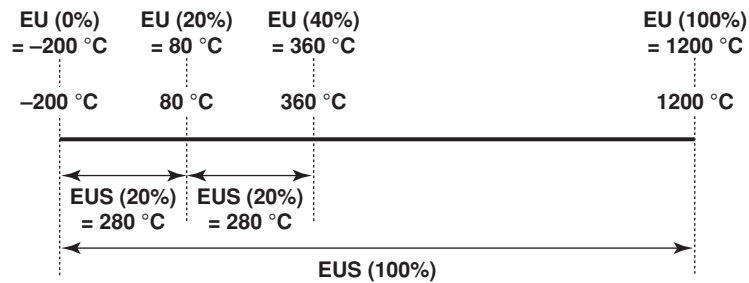

Appendix 9 Program Control Worksheets

Below are convenient worksheets for setting program control parameters. The excel file (program_worksheet_e.xls) containing these worksheets is available in the "english" directory on the accompanying CD-ROM "CX1000/CX2000 Electronic Manual."

Device Name _____

Pattern initial setting

Pattern number

Segments

Segment setting method Time , Ramp

Pattern name

Operating loop

Loop 1

Loop 2

Loop 3

Loop 4

Loop 5

Loop 6

Wait action setting

		1	2	3	4	5
Loop 1	High					
	Low					
Loop 2	High					
	Low					
Loop 3	High					
	Low					
Loop 4	High					
	Low					
Loop 5	High					
	Low					
Loop 6	High					
	Low					
Wait time						

Pattern start setting

Start target setpoint

Loop 1

Loop 2

Loop 3

Loop 4

Loop 5

Loop 6

Start code

Starting target setpoint start

- PV1 ramp-prioritized start
- PV2 ramp-prioritized start
- PV3 ramp-prioritized start
- PV4 ramp-prioritized start
- PV5 ramp-prioritized start
- PV6 ramp-prioritized start

- PV time-prioritized start

Repeat action setting

Repeat frequency

Repeat start segment

Repeat end segment

PV event

	___1	___2	___3	___4	___5	___6	___7	___8	___9	___0
PVE loop number										
PVE1 event kind										
PVE1 value										
PVE2 loop number										
PVE2 event kind										
PVE2 value										
PVE3 loop number										
PVE3 event kind										
PVE3 value										
PVE4 loop number										
PVE4 event kind										
PVE4 value										
PVE5 loop number										
PVE5 event kind										
PVE5 value										
PVE6 loop number										
PVE6 event kind										
PVE6 value										
PVE7 loop number										
PVE7 event kind										
PVE7 value										
PVE8 loop number										
PVE8 event kind										
PVE8 value										
PVE9 loop number										
PVE9 event kind										
PVE9 value										
PVE10 loop number										
PVE10 event kind										
PVE10 value										
PVE11 loop number										
PVE11 event kind										
PVE11 value										
PVE12 loop number										
PVE12 event kind										
PVE12 value										
PVE13 loop number										
PVE13 event kind										
PVE13 value										
PVE14 loop number										
PVE14 event kind										
PVE14 value										
PVE15 loop number										
PVE15 event kind										
PVE15 value										
PVE16 loop number										
PVE16 event kind										
PVE16 value										

PV event hysteresis

1	%	9	%
2	%	10	%
3	%	11	%
4	%	12	%
5	%	13	%
6	%	14	%
7	%	15	%
8	%	16	%

Appendix 9 Program Control Worksheets

Event output

Time event

	On/Off	No.		On/Off	No.
1			9		
2			10		
3			11		
4			12		
5			13		
6			14		
7			15		
8			16		

PV event

	On/Off	No.		On/Off	No.
1			9		
2			10		
3			11		
4			12		
5			13		
6			14		
7			15		
8			16		

Program pattern end signal

	On/Off	No.

Appendix 10 Expression Examples

The following are simple application examples using expressions. Refer to them when using computation channels.

Counter

Function
This is a counter that counts from 1 to 15.

Expression
 $31 = 31*(31.LT.K02)+K01$
 $K01=1$
 $K02=15$

Explanation
 When the value of channel 31 is smaller than 15, the value of (31.LT.K02) is 1. The value of channel 31 increments by 1 every scan interval.
 When the value of channel 31 is 15, the value of (31.LT.K02) becomes 0. The value of $31*(31.LT.K02)+K01$ returns to 1.

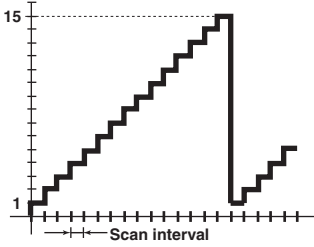

Note

Computation channels are processed in sequence. The value of the previous scan is used in the computation for its own channel number and channel numbers greater than its own channel number in the expression. In this example, a value one scan behind is used for "31" in " $31*(31.LT.K02)+K01$."

Resetting and Carrying Over an Excess When the Integrated Value Exceeds a Certain Value

Function
If the measured values on channel 1 are integrated and the total exceeds 1000, 1000 is subtracted from the total, and integration continues.

Scan Interval
1 second

Channel 1
Measuring range: 0.0–50.0 L/M (liters per minute)

Expression
 $31 = (31+(01/K01))-(31.GE.K02)*K02$
 $K01 = 60$ (unit of time of the measured flow on channel 1 ÷ scan interval, or in this case, 60 sec. ÷ 1 sec = 60)
 $K02 = 1000$ (reset if the integrated value exceeds this value)

Explanation
 $(31+(01/K01))$ calculates the integrated value on channel 1.
 When the value of channel 31 is smaller than 1000, the value of (31.GE.K02) is 0. The value of (31.GE.K02)*K02 is 0.
 When the value of channel 31 is 1000 or higher, the value of (31.GE.K02) is 1. The value of (31.GE.K02)*K02 is 1000. 1000 is subtracted from the integrated value, and integration continues.

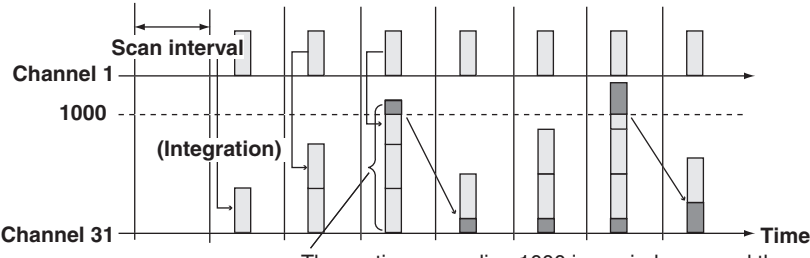

Applies a Lowcut and Highcut to Measured Values and Integrates Them

Function

Cuts (sets to 0) measured values on channel 1 that are negative or greater than 15, and integrates them.

Expression

$$31 = ((01.GE.K01)AND(01.LE.K02))*01$$

$$32 = TLOG.SUM(31)$$

$$K01 = 0$$

$$K02 = 15$$

Explanation

When the value of channel 1 is negative, (01.GE.K01) is 0. When the value of channel 1 exceeds 15, (01.LE.K02) is 0. Therefore, when the value of channel 1 is negative or exceeds 15, the value of channel 31 is 0. Channel 32 integrates the measured value of channel 31.

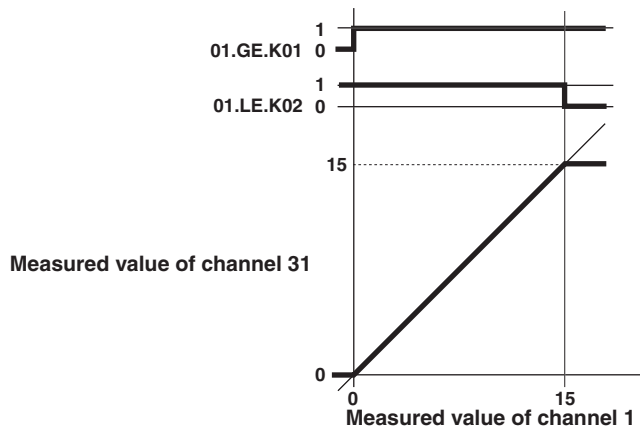

Setting a Margin around the Value Measured upon Occurrence and Release of Alarms (Alarm Hysteresis)

Function

An alarm occurs when the value of channel 1 is 55 or higher. Once the alarm occurs it is not released until the value of channel 1 falls below 50.

Expression

$$31 = (31OR01.GE.K01)AND01.GE.K02$$

$$K01 = 55$$

$$K02 = 50$$

Set an upper limit alarm on channel 31 with an alarm value of 1.

Explanation

When the value of channel 1 gradually increases to 50 or higher, 01.GE.K02 becomes 1. When the value of channel 1 increases further to 55 or higher, 01.GE.K01 becomes 1. The value of channel 31 becomes 1, and an upper limit alarm occurs on channel 31.

When the value of channel 31 is 1, it remains at that value even if the value of channel 1 falls in the range from 50 to 55. If the value of channel 1 decreases further to below 50, the value of channel 31 becomes 0. The upper limit alarm on channel 31 is released.

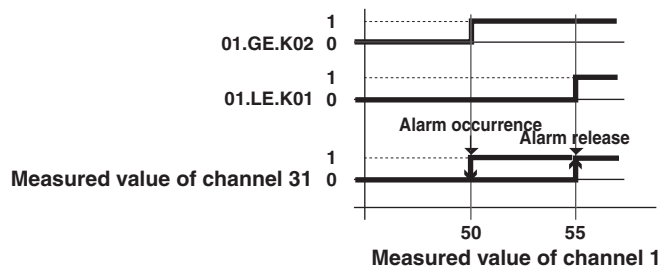

Displaying the Average Value

Function

Averages the measured values on channel 1 every 5 minutes and displays the result.

Scan Interval

1 second

Expression

$31 = 31*(31.LT.K02)+K01$

$32 = 32*(31.NE.K01)+01$

$33 = 32/31$

$34 = (33*(31.EQ.K02))+(34*(31.NE.K02))$

$K01 = 1$

$K02 = 300$

Explanation

Channel 31 is a counter that increments by 1 every scan interval. It counts from 1 to 300, and then repeats.

Channel 32 integrates the measured values on channel 1 until channel 31 reaches 300.

Channel 33 calculates the average value of channel 1.

Channel 34 displays the value of channel 33 when channel 31 is 300, and holds that value until the next time channel 31 becomes 300.

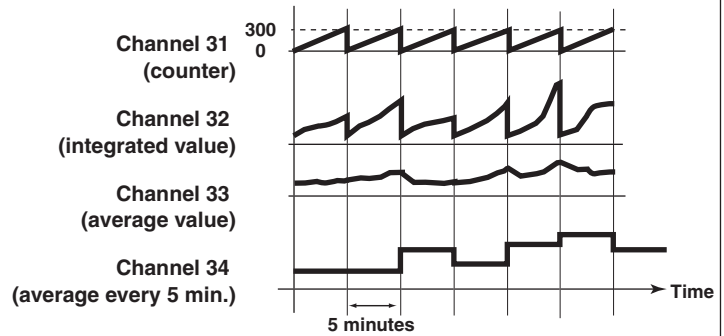

Index

Symbols

4 screen display	1-83
6/4 loop select	1-17, 1-18, 4-2

A

A/D converter, integration time of	1-60
A1	6-11
A2	6-11
A3	6-11
A4	6-11
access lamp	3-2
accessories, optional	v
accessories, standard	v
action	4-22, 7-10, 10-9, 11-12
ADVANCE	6-16
advance	6-21
alarm	1-39, 1-63, 2-7, 8-1
alarm delay	7-9, 10-7
alarm hysteresis	1-40, 1-65
alarm icon	1-72
alarm indication	1-67, 1-86
alarm mode	1-39, 4-9
alarm On/Off	4-22
alarm operating conditions	1-39
alarm output	1-5
alarm relay output	1-65
alarm standby	1-6, 1-40
alarm summary	1-81
alarm type	1-39
alarm value	1-40, 4-22, 7-9, 10-6
AlarmACK	4-21, 7-8, 11-12
all channel display	8-8, 8-10
analog control input terminal block	2-5
analog input for loop control	1-2
analog output, selection of	1-21
analog retransmission	1-8, 1-98, 4-39
Analog-output type	4-12
AND	7-9
AND/OR	1-66
anti-reset windup	1-36
ASCII file	App-19
AT	6-11
ATA flash memory card	3-17
AUT	6-2
auto logout	11-6
auto message for program run/reset	5-14
auto operation	1-6
auto save	1-91
auto save interval	9-5
auto tuning	1-57, 4-2, 6-9

B

background color	8-27
backlight saver	1-88, 3-13
bar graph	8-21
bar graph display	1-80
basic setting mode	1-12, 3-4
BCD	4-7
bias	1-23, 4-19
block	9-4

block display	1-72
boundary	8-25
brightness of display	3-13
burnout	1-25, 1-61, 4-3, 7-3

C

calculation expression	10-3
calibration	13-2
CAS	6-2
cascade control	1-3, 1-17, 4-2
channel	10-14
channel, assignment of	8-4
channel display color	8-16
character/number input keys	3-2
characters, entry of	3-9
clearing of the memory	3-14
CLOG	1-98
CLOG computation	App-13
CLOG error	4-10
color	8-15
communication command log	11-9
computation	11-12
computation error	1-9, 4-41
computation function	1-94, App-6
computation icon	1-72
computation, starting/stopping/resetting of	10-4
conditional expression	App-14
constant	10-3
contact input (DIGITAL IN/REMOTE) wiring	2-19
contact input, registration of	4-6
contact input/output	1-26
contact output (DIGITAL OUT) wiring	2-20
contact output (LOOP1 to 6) wiring	2-20
control action summary display	1-76
control constant	4-45
control data	1-89
control DIO expansion block	2-7
control direction	1-34, 4-26
control group	1-73
control group display	1-14, 1-73, 6-1
control input terminal (2 loops)	2-12
control input terminal (4 loops)	2-11
control input terminal (6 loops)	2-10
control mode	1-17, 4-2
control operation mode	1-6
control output, changing of	6-3
control output suppressing function	4-23
control output suppression	1-36
control output terminal	2-13
control output terminal block	2-6
control output type	4-12
control parameter	1-4
control period	1-16
controller style	1-14
current output	4-12
cursor, turning off	8-9
cycle time	4-12

D

D	1-33, 6-11
data acquisition to the internal memory	1-89, 9-2, App-1

Index

data length 9-4
data, saving of 1-91
data type 9-3
day/day of the week 9-5, 10-14
DB 6-11
de-energize 1-66
DELAY 6-16
delay lower limit alarm 1-64
delay time 6-12
delay time for starting the program pattern contro 6-19
DELAY TM 6-14
delay upper limit alarm 1-63
derivative time 1-33, 4-26
detection 7-9, 10-7
deviation high & low limit 1-39
deviation high-limit 1-39
deviation low & high limit 1-39
deviation low-limit 1-39
DI 2-6
DI/DO label 4-38
DI/DO status display 1-75
difference lower limit alarm 1-63
difference upper limit alarm 1-63
digital display 1-79
DIGITAL IN 2-6, 2-19
DIGITAL OUT 2-6, 2-20
DIO operation control 1-29
DIO operation monitoring 1-9
DIO operation monitoring function 4-35
DIO type 4-36
direct control 1-34
directory nam 9-6
display color 8-16
display data 1-89, 1-91
display data, loading of 9-10
display direction 8-27
display update rate 8-11
displays, switching of 1-12, 3-5
divisions, number of 8-21
DO 2-6
DR 6-11
DSP LOOP 6-14

E

e-mail transmission function icon 1-72
e-mail transmission log 11-10
edit segment number 5-3
energize 1-66
engineering unit App-46
equation 10-3, App-10
error message log 11-8
error messages 12-1
ESC key 3-2
EU App-46
EUS App-46
EV KIND 6-15
EV ON/OFF 6-15
event 5-8, 9-3
event data 1-89, 1-92
event data, loading of 9-10
event display 6-15
event group 5-16
event kind 5-8
event output 1-28
executing several program pattern 6-18
external storage medium 3-17

external storage medium, drive for 3-2
external storage medium, formatting of 3-19, 9-13
external storage medium icon 1-72

F

faceplate style 1-14
FAIL output 1-6, 1-28, 1-102, 2-7, 4-14
file 9-6
file format 9-14
file management on the external storage medium 9-11
file name 1-93, 9-14
filter 4-20
fixed-point control 1-4
floppy disk 3-17
format 3-19, 9-13
four screen display 1-83, 8-2
front panel 3-1
FTP file transfer log 11-9
FUNC key 3-2
FUNC key operation 3-6
functional ground terminal ii

G

graph 8-21
grid 8-27
group 1-73
group name 4-27, 8-3
Group NO. 6-11
group number 4-27, 8-3

H

H 6-11
header 9-6
high-limit alarm 1-63
historical trend display 1-84, 8-10
historical trend, switching to 8-1
HOLD 6-17
hold 1-66
hold operation 6-20
hold operation mode 6-19
hybrid style 1-14
hysteresis 1-38, 4-33, 7-10

I

I 1-33, 6-11
image data 1-92
indicator, hold 7-10
information display, switching of 8-1
initial PID 1-17, 4-2
initial values App-23
initialization 3-14
input filter 1-22
input range 1-22
input switching condition 1-18
input type 1-22, 1-60, 4-18, 4-30
installation location 2-2
installation procedure 2-3
integral time 1-33, 1-60, 4-26, 7-2
internal switch 1-9
interval 10-9
Item name 4-16

K

key lock	1-99, 11-3
Key lock icon	1-72
kind	4-28

L

language, changing of	3-15
local	1-6
local operation mode	6-19
log display	1-100, 11-8
logic computation	1-98, 4-43
login/logout	11-5
login/logout log	11-8
logout	1-100
loop	5-9
loop control with PV switching	1-3, 1-18
loop number	4-2
low-cut	4-19
low-signal cutoff point	1-24
lower limit alarm	1-63
lower limit on rate-of-change alarm	1-63

M

MAN	6-2
manual operation	1-6
manual reset	1-34, 4-26
manual sample	11-13
manual sampled data	1-90, 1-92
manual save	1-91
manual tuning	1-56, 6-10
math On/Off	10-2
math reset	11-12
measured data, clearing of	9-15
measurement alarm	1-63
measurement alarm option terminal block	2-7
measurement group	1-73, 8-3
measurement input terminal	2-14
measurement input terminal block	2-8
measurement input wiring	2-18
measurement span	1-22
media	3-17
media save	9-3
MEMORY	2-8
memory	1-89
memory alarm	7-10
memory, clearing of	3-14
memory end output	1-102
memory information, displaying of	8-10
memory summary	1-82
MENU key	3-2
message	1-77, 8-12, 11-13, 12-1
message summary	1-82
Mode	6-2
mode	1-22, 1-60, 4-18, 7-3, 9-3, 10-9
MODEL	iv
module	4-6
moving average	1-62, 7-5
MR	6-11

N

nonhold	1-66
number	4-28, 7-9, 10-7, 11-6

O

OH	6-11
OL	6-11
on-time/off-time	5-9
ON/OFF control	1-38, 4-12
operation mode	3-4, 6-19
operation mode during program control	6-19
operation status indication section	1-69
option terminal	2-15
OUT	1-3, 6-3
output high-limit	1-39
output low-limit	1-39
output upper/lower limit	1-33
output velocity limiter	1-37
over-integration prevention	1-36
overshoot suppression	1-36
overview display	1-74, 1-81, 6-8, 8-9
overview display, switching of	6-8

P

P	1-33, 6-11
Panel1Load to Panel3Load	11-13
partial expanded display	1-79, 8-25
parts replacement	13-4
password	11-4, 11-7
pattern name	5-3
pattern number	5-3, 5-5, 5-6, 5-8, 5-11, 6-12, 6-16
periodic inspection	13-1
PID constant	1-33
PID control mode	1-3, 4-3
PID group number	1-16, 4-2
PID, initial value	1-17, 4-2
PID number	1-32, 4-26
PID selection method	1-4, 1-16
PO	6-11
power supply for transmitters	1-103, 2-23
power supply, wiring of	2-21
pre-trigger	9-4
preset output	1-35, 4-26
program control	1-10, 4-3
program control mode	6-19
program control, starting	6-19
program display position	5-15
program pattern name	6-12, 6-16
program pattern start segment, selection of	6-19
program selection display	6-12
proportional band	1-33, 4-26
PT NO.	6-13
PV	1-2, 1-3, 2-5
PV event hysteresis	5-10
PV high-limit	1-39
PV low-limit	1-39
PV range conversion	1-24
PV range lower/upper limit	4-19
PV switching lower/upper limit	4-19
PV tracking	1-25
PV/SP computation	1-7, 1-98, 4-39
PV/SP computation function	4-9
PVEvent	5-8

R

ramp	5-7
ramp-rate time unit	4-24, 5-7
ramp/soak select	5-6

Index

range 1-22, 1-61, 4-18, 7-3
rate-of-change alarm 7-10
ratio setting 4-20
rear panel 3-3
reference deviation 1-33, 4-24
reference point 1-16, 1-32, 4-24
reference time 10-9
reflash alarm 7-9
registering contact inputs (BCD) 4-48
relay 7-9
relay action/behavior 4-14
relay contact output 4-12
relay hold 7-10
relay hysteresis 1-38
relay hysteresis value and activation point 4-26
relay output 7-9, 10-6
relay output/number 4-22
REM/LOC 6-4
remaining segment time 6-17
REMOTE 2-7, 2-19
remote 1-6, 4-3
remote input 1-28, 1-103, 11-11
Remote/Local, switching between 6-4
repeat 6-12, 6-16
repeat action 5-11
repeat end segment 5-11
repeat frequency 5-11
repeat start segment 5-11
replacement period 13-4
report channel 10-14
report data 1-83, 1-90, 1-92
report function 1-95, App-16
report function, starting/stopping of 10-15
report types 10-14
RESET 6-16
reset 10-9
reset mode 6-19
restart mode 1-17, 4-2
reverse control 1-34
revision history vii
RJC 1-25, 1-61, 4-3, 7-3
RSP 1-2, 2-5
RSP input 1-6, 1-31
RSP input selection 4-9
RST 6-16
RUN 6-16
run/auto/cascade, switching between 6-2
RUN/RST 6-16
run/stop operation 1-7, 6-1
RUN/STP 6-2

S

sample rate 9-3
samples, number of 10-11
sampling interval 10-11
save 1-91
save data 9-6
scale 4-19, 7-5
scale display ON/OFF 8-8
scale lower/upper limit 4-19
scale, number of digits displayed 8-23
scale position 8-21
scan interval 1-60, 7-2
screen image data, saving of 9-14
scroll 8-27
SEG TIME 6-17
segment edit 5-3

SEGMENT NO 6-13
segment number 5-6, 5-8, 6-12, 6-16
segment PID group No. 5-7
segment setting method 5-3
SEGMENT TIME 6-13
segment time 5-7, 6-12, 6-16
segments 5-3
self diagnosis 4-14
self diagnosis output 1-6, 1-28
setpoint limiter 1-31
settings, initialization of 3-14
setup data 1-93
setup data, loading and saving of 9-9
setup mode 3-4
shunt resistor 4-19, 7-3
shutdown function 1-34, 4-26
single-loop control 1-3, 1-17, 4-2
snapshot 11-13
soft keys 3-2
SP 1-2, 1-3, 1-30, 1-38, 4-26, 6-3, 6-11
SP, changing of 6-2
SP high-limit 1-39
SP low-limit 1-39
SP NO. 6-11
SP number 4-22
SP number selection source 4-9
SP ramp-down-rate/SP ramp-up-rate 4-24
SP ramp-up-rate/SP ramp-down-rate 1-31
span 1-22, 1-61, 4-18, 7-4
span upper/lower limit 10-3
specifying the program pattern using BCD 4-47
split window display 6-20
square-root computation 1-24, 4-19
ST SEG 6-14
standard PID control 1-4
standard signal 1-22
standby 4-22
start code 5-5
start segment number 6-12
start/stop 11-12
START/STOP key 3-2, 3-7
storage function 1-89
style number i
SUFFIX iv
sum scale 10-10, 10-14
switching condition 1-18, 4-3
switching hysteresis 1-32, 4-24
switching pattern number 6-18
system information display 1-101, 11-10

T

tag/channel 8-6
tag/tag comment 4-24
tags 1-73, 8-6, 10-3
target setpoint 5-7, 6-17
target setpoint selection method 1-4, 1-16
target setpoint tracking 1-30
ten-segment linearizer approximation 1-23
ten-segment linearizer biasing 1-23
ten-segment linearizer I/O 4-30
ten-segment linearizer mode 4-30
time 9-5, 10-14
time adjustment 11-12
time, setting of 3-11
time zone, changing of 3-16
TimeEvent 5-8
timer number 10-10

timeup type	9-5
TLOG	10-10
TLOG data	1-92
trend display	1-77
trend line width	8-27
trigger	9-4, 11-12
trip line	8-14
trip line width	8-27
troubleshooting	12-11
TSP CHG	6-17
TUNING	6-5
tuning	1-56
tuning display	1-74
tuning display, switching to	6-5
tuning operation	6-9
tuning parameters ON/OFF	4-16
type	1-22, 1-60, 4-18, 4-22, 5-9, 7-8, 9-13, 10-6

U

unit	1-22, 4-19, 10-3
upper limit on rate-of-change alarm	1-63
user ID	11-6, 11-7
USER key	1-99, 3-2, 3-7
USER key assignment	11-1
user name	11-7

V

value, entry of	3-9
VGA output	1-103, 2-22
voltage pulse output	4-12

W

WAIT	6-16
wait	5-7
wait operation	6-21
wait time	5-4
wait zone number	5-4
Web browser operation log	11-9

Z

Zip disk	3-17
zone display	1-78
zone lower/upper limit	8-19
zone PID method	1-5, 1-16, 1-32
zone PID selection	1-16, 4-2
zooming in on the time axis	8-10